

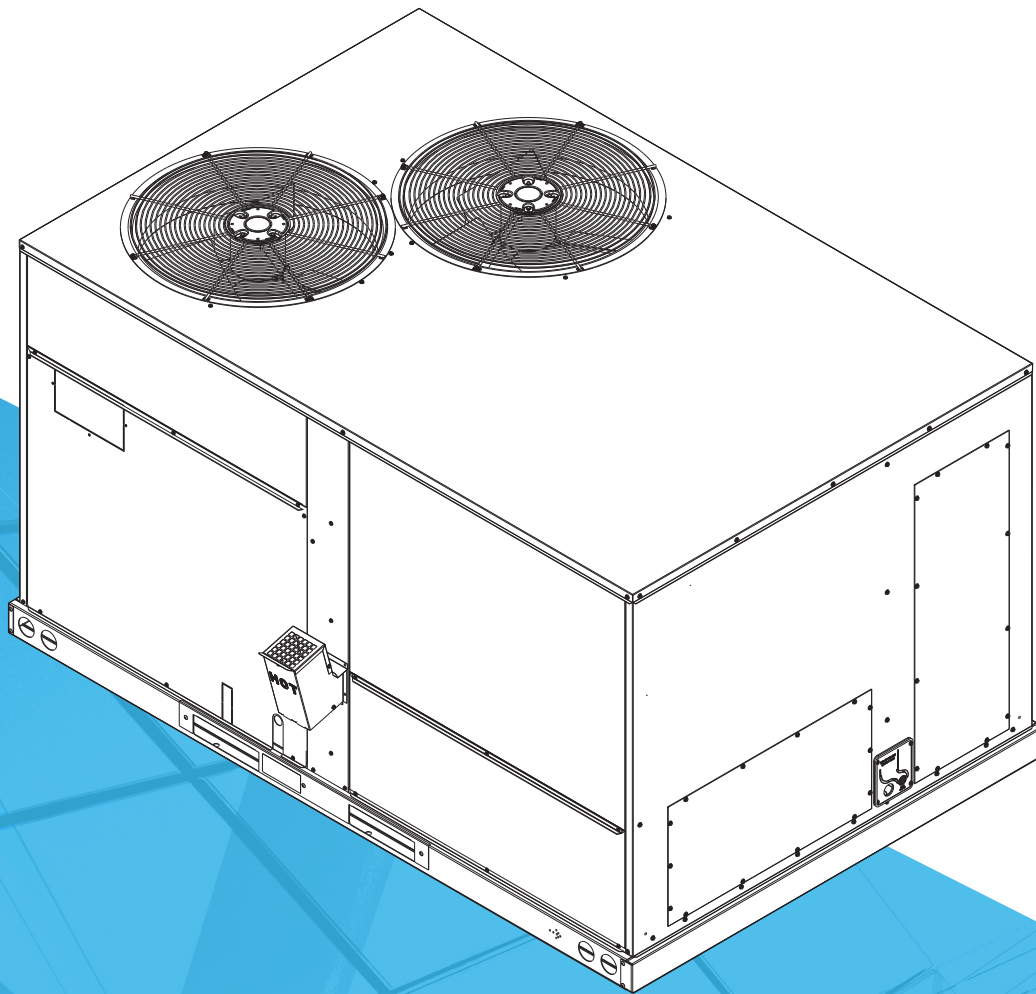

# MAVERICK® I

COMMERCIAL PACKAGE ROOFTOP SYSTEMS



- HEATING AND COOLING MODELS
- MPSA07D - MPSA12D
- 7 THROUGH 12 TONS
- R-410A REFRIGERANT

# Table of Contents

- Introduction** ..... 3
  - General ..... 3
  - Checking Product Received ..... 3
  - Safety Information ..... 3
- Mechanical Installation** ..... 4
  - Major Components ..... 4
  - General ..... 4
  - Clearances ..... 6
  - Rooftop Installation ..... 6
  - Ductwork ..... 8
  - HGRH System ..... 8
  - Refrigerant Solenoid Valves ..... 8
  - Variable Frequency Drive (VFD) ..... 9
  - Outdoor Fan Motor Controller (OFMC) ..... 9
- Electrical Installation** ..... 13
- Wiring Diagrams** ..... 16
- Unit Capacity and Physical Data** ..... 53
- Electrical Data** ..... 54
  - Compressor and Condenser Motor ..... 54
  - MCA and MCOP ..... 54
  - Auxiliary Heater Data ..... 55
- Dimensional Data** ..... 56
  - Unit Dimensions ..... 56
  - Duct Dimensions ..... 57
  - Curb Dimensions ..... 57

- Performance Data** ..... 58
  - Airflow Performance ..... 58
  - Non-DDC Economizer for Downflow Duct Install . . . 67
  - Non-DDC Economizer for Horizontal Duct Install . . . 68
  - DDC Economizer for Downflow Duct Install ..... 69
  - DDC Economizer for Horizontal Duct Install ..... 70
  - Fresh Air Dampers and Power Exhaust ..... 71
  - Fresh Air Damper ..... 73
  - Non-Motorized Damper Kit ..... 74
  - Roof Curbs ..... 75
- Controls and Operation** ..... 76
  - Furnace Section Controls and Ignition System ..... 76
- Maintenance** ..... 79
  - General ..... 79
  - System Charging Charts ..... 81
- Troubleshooting** ..... 89
  - Cooling Troubleshooting Chart ..... 89
  - Furnace Troubleshooting Guide ..... 90
- Warranty** ..... 92
  - Limited Product Warranty ..... 92
  - Replacement Parts ..... 92
  - Rooftop Warranty Registration Form ..... 93

©2024 Daikin Applied, Minneapolis, MN. All rights reserved throughout the world. This document contains the most current product information as of this printing. Daikin Applied Americas Inc. has the right to change the information, design, and construction of the product represented within the document without prior notice. For the most up-to-date product information, please go to [www.DaikinApplied.com](http://www.DaikinApplied.com).

™@ MicroTech, SiteLine, and Daikin Applied are trademarks or registered trademarks of Daikin Applied Americas Inc. The following are trademarks or registered trademarks of their respective companies: BACnet from American Society of Heating, Refrigerating and Air-Conditioning Engineers, Inc.; Echelon, LonWorks, LonMark, and LonTalk from Echelon Corporation; Modbus from Schneider Electric; and Windows from Microsoft Corporation..

# Introduction

## General

This manual contains the installation and operating instructions for your packaged rooftop system. There are some precautions that should be taken to derive maximum satisfaction from it. Improper installation can result in unsatisfactory operation or dangerous conditions.

Read this manual and any instructions packaged with separate equipment prior to installation. Give this manual to the owner and explain its provisions. The owner should retain this manual for future reference.

This product line does have an optional DDC controller. For operation and information on using and programming the MicroTech® II unit controller, refer to the appropriate operation manual (see [Table 1](#)).

For a description of operation and information on using the keypad to view data and set parameters, refer to the appropriate program-specific operation manual (see [Table 1](#)).

**Table 1: Operation, Installation and Maintenance Resources**

Rooftop Unit Control Configuration	Operation Manual Bulletin Number
DDC Unit Controller	<a href="#">OM 1077</a>
BACnet Communication Module	<a href="#">IM 1000</a>
LonWorks Communication Module	<a href="#">IM 999</a>

## Checking Product Received

Upon receiving the unit, inspect it for any damage from shipment. Claims for damage, either shipping or concealed, should be filed immediately with the shipping company. **IMPORTANT:** Check the unit model number, heating size, electrical characteristics, and accessories to determine if they are correct.

## Safety Information

### NOTICE

The manufacturer's warranty does not cover any damage or defect to the air conditioner caused by the attachment or use of any components, accessories or devices (other than those authorized by the manufacturer) into, onto, or in conjunction with the air conditioner. You should be aware that the use of unauthorized components, accessories or devices may adversely affect the operation of the air conditioner and may also endanger life and property. The manufacturer disclaims any responsibility for such loss or injury resulting from the use of such unauthorized components, accessories or devices.

### WARNING

Provide adequate combustion and ventilation air to the unit space as specified in the combustion and ventilation air section of these instructions.

### WARNING

Install this unit only in a location and position as specified in the Mechanical Installation section of these instructions. Provide adequate combustion and ventilation air to the unit space as specified in the venting section of these instructions.

### DANGER

Combustion products must be discharged outdoors. Connect this unit to an approved vent system only, as specified in Mechanical Installation section of these instructions. Use only with type of gas approved for this unit. Refer to the unit rating plate.

### DANGER

Never test for gas leaks with an open flame. It can cause an explosion or fire resulting in property damage, personal injury or death. Use a commercially available soap solution made specifically for the detection of leaks to check all connections, as specified in the Mechanical Installation section of these instructions.

### WARNING

Always install unit to operate within the unit's intended temperature-rise range with a duct system which has an external static pressure within the allowable range, as specified in the Mechanical Installation section of these instructions. See also unit rating plate.

### WARNING

Units are not design certified to be installed inside the structure. Doing so can cause inadequate unit performance as well as property damage and carbon monoxide poisoning resulting in personal injury or death.

# Mechanical Installation

## Major Components

The unit includes a hermetically-sealed refrigerating system consisting of a scroll compressor, condenser coil, evaporator coil with capillary tube assembly, circulation air blower, condenser fan, heat exchanger assembly, gas burner and control assembly, combustion air motor and fan, and all necessary internal electrical wiring. The unit's cooling system is factory-evacuated, charged and performance tested. Refrigerant amount and type are indicated on rating plate.

The unit is available in 150,000, 225,000 and 252,000 BTUH heating input. Cooling capacity is 6.5, 7.5, 8.5, 10 and 12 nominal tons. Units are convertible from bottom supply and return to side supply and return by relocation of supply and return air cover panels. The units are weatherized for mounting outside of the building.

## General

### WARNING

When a unit is installed so that supply ducts carry air circulated by the unit to areas outside the space containing the unit, the return air shall also be handled by duct(s) sealed to the unit casing and terminating outside the space containing the unit.

Install this unit in accordance with The American National Standard Z223.1-latest edition manual entitled "National Fuel Gas Code," and the requirements or codes of the local utility or other authority having jurisdiction.

Additional helpful publications available from the "National Fire Protection Association" are: sNFPA-90A - Installation of Air Conditioning and Ventilating Systems 1985 or latest edition. NFPA-90B - Warm Air Heating and Air Conditioning Systems 1984.

These publications are available from:

National Fire Protection Association, Inc.  
Batterymarch Park  
Quincy, MA 02269

## Pre-Installation Check-Points

Before attempting any installation, carefully consider the following points:

1. Structural strength of supporting members (rooftop installation)
2. Clearances and provision for servicing power supply and wiring
3. Gas supply and piping
4. Air duct connections and sizing
5. Drain facilities and connections
6. Location for minimum noise and vibration - away from bedroom windows

## Location Considerations

### WARNING

This unit may be used to heat the building or structure during construction if the following installation requirements are met. Installation must comply with all installation instructions including:

- Proper vent installation
- Furnace operating under thermostatic control
- Return air duct sealed to the furnace
- Air filters in place
- Set furnace input rate and temperature rise per rating plate marking
- Means of providing outdoor air required for combustion
- Return air temperature maintained between 55°F (13°C) and 80°F (27°C)
- Installation of exhaust and combustion air inlet hoods completed
- Clean furnace, duct work and components upon substantial completion of the construction process, and verify furnace operating conditions including ignition, input rate, temperature rise and venting, according to the instructions.

The metal parts of this unit may be subject to rust or deterioration in adverse environmental conditions. This oxidation could shorten the equipment's useful life. Salt spray, fog or mist in seacoast areas, sulphur or chlorine from lawn watering systems, and various chemical contaminants from industries such as paper mills and petroleum refineries are especially corrosive.

If the unit is to be installed in an area where contaminants are likely to be a problem, give special attention to the equipment location and exposure.

1. Avoid having lawn sprinkler heads spray directly on the unit cabinet.
2. In coastal areas, locate the unit on the side of the building away from the waterfront.
3. Shielding by a fence or shrubs may give some protection.
4. Frequent washing of the cabinet, fan blade and coil with fresh water will remove most of the salt or other contaminants that build up on the unit.
5. Regular cleaning and waxing of the cabinet with a good automobile polish will provide some protection.
6. A good liquid cleaner may be used several times a year to remove matter that will not wash off with water.

Several different types of protective coatings are offered in some areas. These coatings may provide some benefit, but the effectiveness of such coating materials cannot be verified by the equipment manufacturer.

**The best protection is frequent cleaning, maintenance, and minimal exposure to contaminants.**

## Outside Installation

### WARNING

These units are designed certified for outdoor installation only. Installation inside any part of a structure can result in inadequate unit performance as well as property damage. Installation inside can also cause recirculation of flue products into the conditioned space resulting in personal injury or death.

Typical outdoor slab installation is shown in [Figure 1](#).

1. Select a location where external water drainage cannot collect around unit.
2. Provide a level slab sufficiently high enough above grade to prevent surface water from entering the unit
3. Locate the unit to provide proper access for inspection and servicing as shown in [Figure 3 on page 6](#)
4. Locate unit where operating sounds will not disturb owner or neighbors.
5. Locate unit so roof runoff water does not pour directly on the unit. Provide gutter or other shielding at roof level. Do not locate unit in an area where excessive snow drifting may occur or accumulate.
6. Where snowfall is anticipated, the height of the unit above the ground level must be considered. Mount unit high enough to be above anticipated maximum area snowfall and to allow combustion air to enter the combustion air inlet.
7. Select an area which will keep the areas of the vent, air intake, and A/C condenser fins free and clear of obstructions such as weeds, shrubs, vines, snow, etc. Inform the user accordingly.
8. Remove compressor shipping supports (if so equipped) after installation.

**Figure 1: Outside Slab Installation**

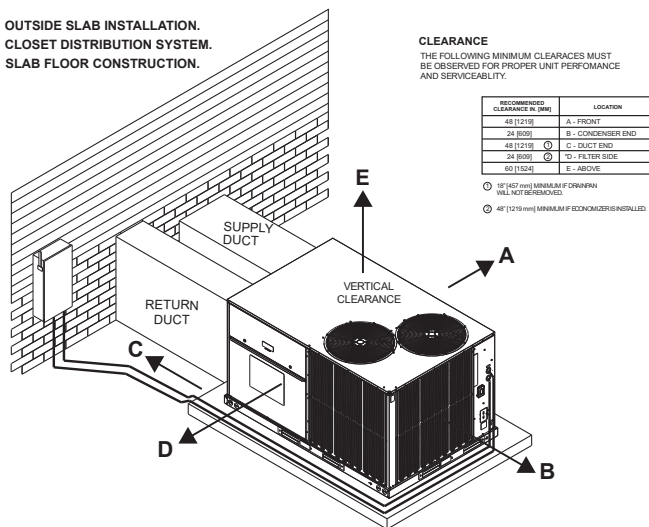

## Attaching Exhaust and Combustion Air Inlet Hoods

**IMPORTANT:** Do not operate this unit without the exhaust/combustion air inlet hood properly installed. This hood is shipped in a carton in the blower compartment inside the unit and must be attached when the unit is installed. See [Figure 46 on page 67](#).

To attach exhaust/combustion air inlet hood:

1. Remove screws securing blower access panel and remove access panel. For location of blower access panel, see [Figure 35 on page 56](#).
2. Remove exhaust/combustion air inlet hood from the carton, located inside the blower compartment.
3. Attach blower access panel.
4. Attach the combustion air inlet/exhaust hood with screws. Reference [Figure 35 on page 56](#) for proper location. Screws are in carton with the hood.
5. Vent the unit using the flue exhaust hood, as supplied from the factory, without alteration or addition. The only exception is with factory approved additions. Consult your local utility or other authority having jurisdiction for accepted venting techniques.

## Cover Panel Installation/Conversion Procedure

### Downflow To Horizontal

1. Remove the screws and covers from the outside of the supply and return sections. See [Figure 2](#).
2. Install the covers over the bottom supply and return openings, painted side up, inserting the leading flange under the bracket provided. Place the back flange to top of the front bracket provided. See [Figure 2](#).
3. Secure the return and supply cover to front bracket with one (1) screw.

**Figure 2: Cover Gasket Detail, Downflow to Horizontal**

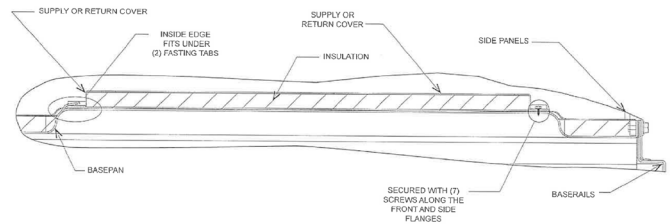

## Clearances

The following minimum clearances must be observed for proper unit performance and serviceability (also see [Figure 3](#)).

**Figure 3: Clearances**

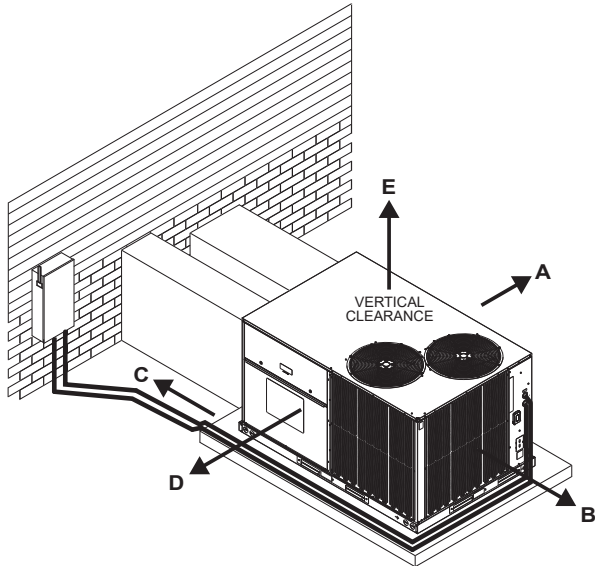

**Table 2: Recommended Clearances**

Recommended Clearance In. [mm]	Location
48 [1219]	A - Front
24 [609]	B - Condenser End
48 [1219] <sup>1</sup>	C - Duct End
24 [609] <sup>2</sup>	D - Filter Side
60 [1524]	E - Above

1. 18" [457 mm] Minimum if drain pan will not be removed.
2. 48" [1219 Mm] Minimum if economizer is installed.

## Rooftop Installation

1. Before locating the unit on the roof, make sure that the roof structure is adequate to support the weight involved. (See Electrical & Physical Tables in this manual.) **THIS IS VERY IMPORTANT AND THE INSTALLER'S RESPONSIBILITY.**
2. For rigging and roofcurb details, see [Figure 5](#) through [Figure 7](#).
3. The location of the unit on the roof should be such as to provide proper access for inspection and servicing.

**IMPORTANT:** If unit will not be put into service immediately, block off supply and return air openings to prevent excessive condensation.

**Figure 4: Flat Rooftop Installation, With Attic or Drop Ceiling Distributing System**

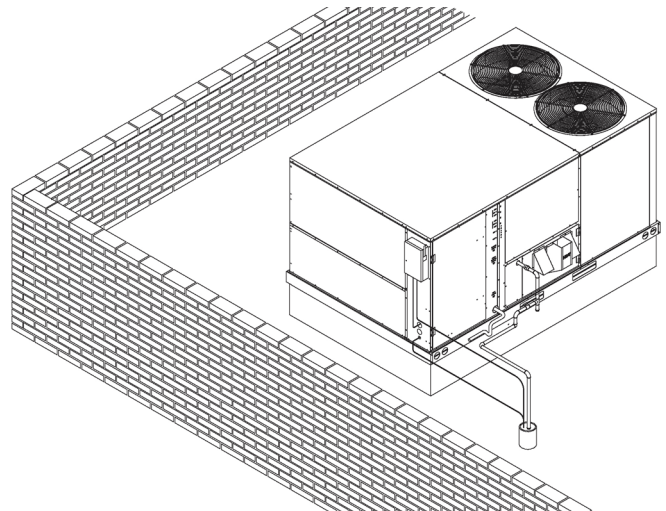
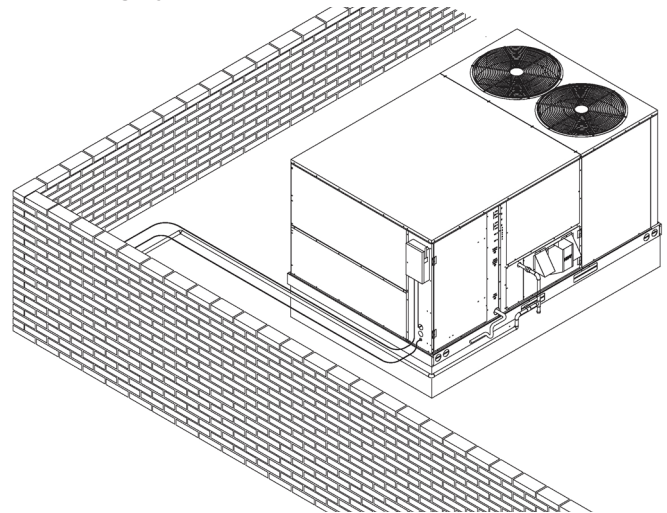

Figure 5: Rigging Detail

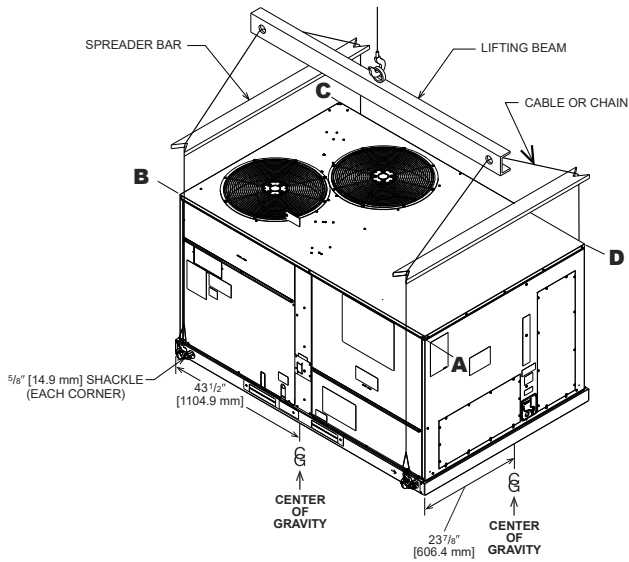

Figure 6: Shipping Board Removal

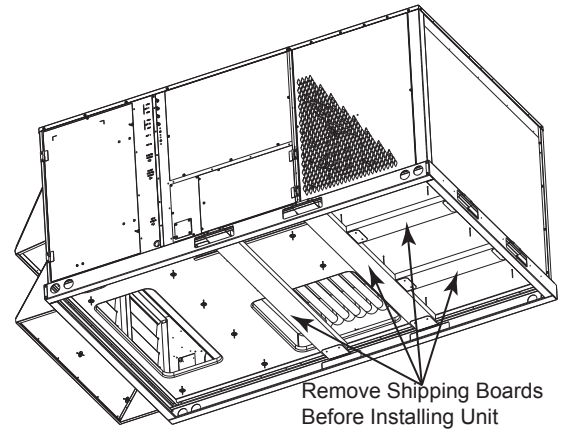
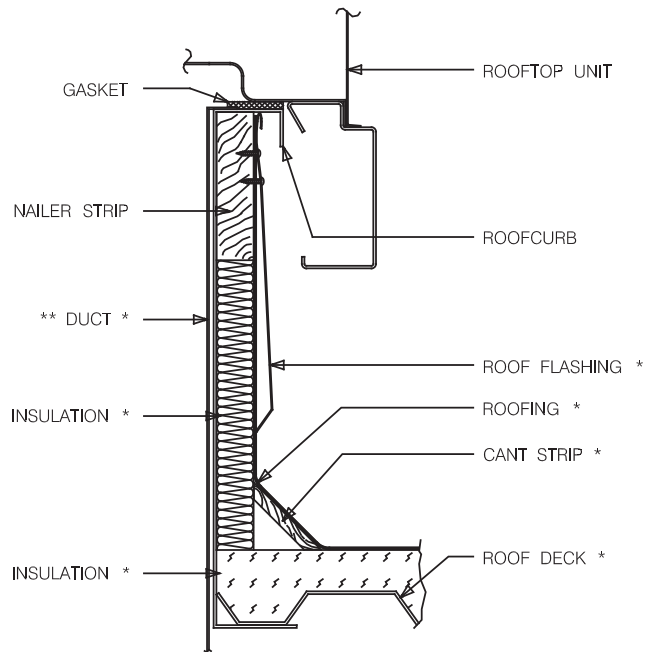
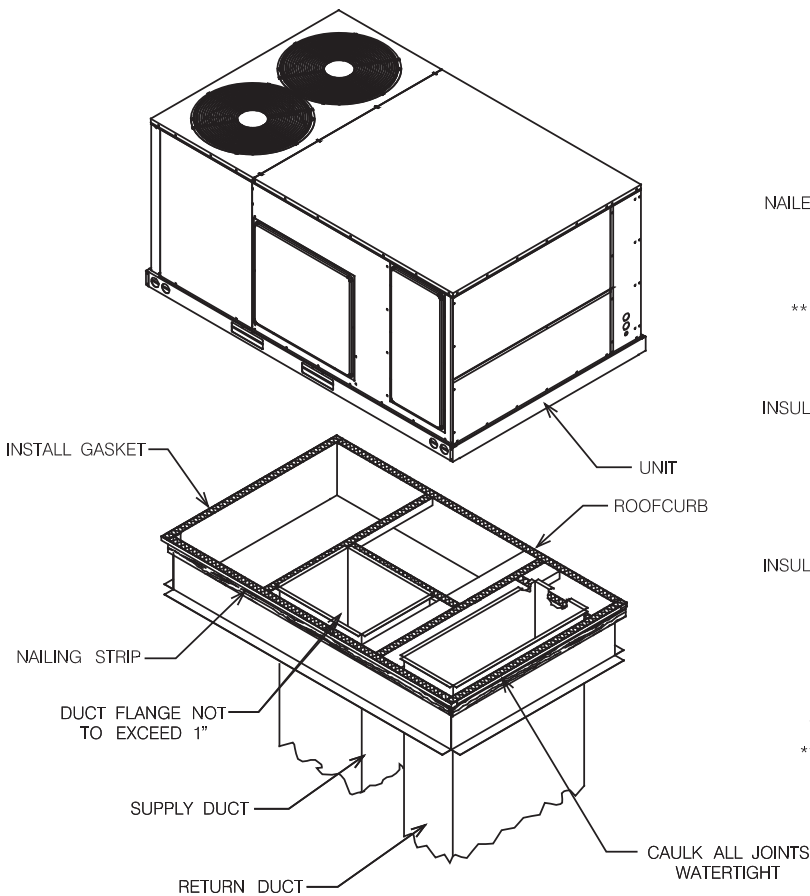

Table 3: Corner Weights

Capacity Tons [kW]	Corner Weights by Percentage			
	A	B	C	D
7.5 – 12.5 [21.1 – 44.0]	26%	34%	17%	23%

Figure 7: Roof Curb



\* BY CONTRACTOR  
 \*\* FOR INSTALLATION OF DUCT AS SHOWN, USE RECOMMENDED DUCT SIZES FROM ROOFCURB INSTALLATION INSTRUCTIONS. FOR DUCT FLANGE ATTACHMENT TO UNIT, SEE UNIT INSTALLATION INSTRUCTIONS FOR RECOMMENDED DUCT SIZES.

## Ductwork

### WARNING

Never connect return ductwork to any other heat producing device such as fireplace insert, stove, etc. Unauthorized use of such devices may result in fire, carbon monoxide poisoning, explosion, personal injury, property damage or death.

The installing contractor should fabricate ductwork in accordance with local codes. Use industry manuals as a guide when sizing and designing the duct system. Contact [Air Conditioning Contractors of America](#), 1513 16th St. N.W., Washington, D.C. 20036.

Place the unit as close to the conditioned space as possible allowing clearances as indicated. Run ducts as directly as possible to supply and return outlets. Use of non-flammable weatherproof flexible connectors on both supply and return connections at unit to reduce noise transmission is recommended.

On ductwork exposed to outside temperature and humidity, use a minimum of 2" of insulation and a vapor barrier. Distribution system in attic, furred space or crawl space should be insulated with at least 2" of insulation. 1/2" to 1" thick insulation is usually sufficient for ductwork inside the air conditioned space.

Provide balancing dampers for each branch duct in the supply system. Properly support ductwork from the structure.

**IMPORTANT:** In the event that the return air ducts must be run through an "unconfined" space containing other fuel burning equipment, it is imperative that the user be informed against future changes in construction which might change this to a "confined space." Also, caution the user against any future installation of additional equipment (such as power ventilators), within the existing unconfined and/or confined space which might create a negative pressure within the vicinity of other solid, liquid, or gas fueled units.

## Return Air

### WARNING

Never allow products of combustion or the flue products to enter the return air ductwork, or the circulating air supply. All return ductwork must be adequately sealed and secured to the furnace with sheet metal screws and joints must be taped. All other duct joints must be secured with approved connections and sealed airtight.

Failure to prevent products of combustion from being circulated into the living space can create potentially hazardous conditions, including carbon monoxide poisoning that could result in personal injury or death.

## HGRH System

The HGRH system controls both cooling and humidity loads. In addition to two stages of cooling, the unit includes two stages of reheat. A temperature sensor or thermostat relates a low cooling demand (y1) or high cooling demand (y2) to the RTU-C. A separate humidity sensor sends the actual indoor relative humidity to the RTU-C via a 0-10 VDC signal. The RTU-C considers a relative humidity level 2%-5% above the humidity setpoint as a "low humidity demand" (H1). The RTU-C considers a relative humidity level greater than 5% above the humidity setpoint as a "high humidity demand" (H2). The RTU-C determines the unit mode of operation based on the y1, y2, H1 and H2 (Table 1). Low reheat is only initiated when there is a humidity call (H1 or H2) and no cooling call (y1 or y2). In this mode the unit provides essentially "neutral air" (supply air is within +1°F and -5°F of return air temperature). High reheat is only used when there is a high humidity demand (H2) with a low cooling demand (y1). See OM 1077 manual for reheat unit setup and for thermostat/sensor combinations.

## Humidity Sensor

An indoor relative humidity sensor (not included with the unit) is required for reheat operation.

## Refrigerant Solenoid Valves

The reheat refrigerant system is part of System 1 only. Three refrigerant solenoid valves (discharge, liquid and reheat) are used to change operation from Cooling Mode to Reheat Mode. The Discharge Solenoid Valve (DSV) is located in the outdoor section (front side of unit) and is a normally Closed (n.C.) valve. The Liquid Solenoid Valve (LSV) is located in the liquid line in the blower section and is a normally Open (n.O.) valve. The Reheat Solenoid Valve (RSV) is near the bottom of the reheat coil (between the evaporator coil and the blower) and is normally open.

## Operation

During the Cooling mode the RSV is the only valve energized (closed position), LSV is open, DSV is closed. The refrigeration cycle is standard cooling, reheat coil is bypassed. System 2 operates during High Cooling or High Reheat modes but is not part of the reheat circuit (always operates in standard cooling). During Low Reheat or High Retreat modes the LSV is energized (closed position), DSV is energized (open position), RHV is open. Some hot gas bypasses the condenser coil and creates a warm two phase mix that enters the reheat coil. See Table A for Modes of Operation including compressor operation, fan speed, thermostat/humidistat calls for each mode. See Blower VFD

## Variable Frequency Drive (VFD)

No adjustments of the VFD are required for installation or operation of this unit.

Location: Control Section (front left) of the unit.

**VFD Model:** Schneider Altivar 212 (factory programmed).

## Replacement

The VFD is horsepower and voltage specific therefore; replacement must be the same model as the existing. A preprogrammed VFD is recommended and available from ProStock. A nonprogrammed Schneider Altivar 212 may be used but must be programmed exactly per the included VFD programming guide for safe and proper function.

## Operation

The purpose of the VFD is to allow airflow in Fan Only (G), Low Reheat and First Stage Cooling (y1) operation of a two stage unit. Unit air balancing should be performed at High Airflow (100% at RTUC, 60Hz at VFD) by adjusting the blower motor sheave. High Airflow always occurs during a W1, W2, or y2 call. For air balancing, without heating or cooling, the fan only speed can be temporarily increased to 100% by adjustment through the RTU-C keypad. To meet ASHRAE 90.1-2010 and for best performance, First Stage Cool and Fan Only speeds are factory set at 50% airflow (30 Hz at VFD). Both of these speeds are independently adjustable at the RTU-C. The VFD display will indicate an equivalent value in Hz (i.e. Low Cool adjusted to 60% at RTU-C will display as 36 Hz at the VFD). A 20 second (adjustable at the VFD) ramp-up or rampdown is used whenever the blower speed is increased or decreased. Low speed blower operation first ramps to 75%, to close fan proving switch, before ramping to the desired speed. Since the VFD operates on 24VDC control voltage, a blower relay (with 24VAC across the coil) is used to turn the VFD on. Blower speeds are changed via Modbus communication from the RTU-C.

## Outdoor Fan Motor Controller (OFMC)

Location: Control Section (front left) of the unit.

During Low Reheat Mode the OFMC slows the outdoor fans to increase the discharge pressure/temperature to maintain an optimized amount of reheat required to provide neutral air to the occupied space. The OFMC is located in the control box section. The factory setting for the outdoor fan motor controller is unit specific (Table 4). The setpoint temperature will provide neutral air +1 to -5°F from entering air temperature (example if the entering or return air temperature is 75°F the leaving or supply air temperature will be 76° to 70°F during the reheat mode). If field adjustment is required to raise or lower the leaving air temperature, this may be accomplished by turning the temperature control dial on the OFMC (Figure 8). Turning the dial to a higher temperature setting will increase the leaving or supply air temperature and turning the dial to a lower setting will reduce the leaving or supply temperature. During cooling modes the OFMC will operate at full speed (green light – Figure 8). During reheat modes the OFMC will typically operate at variable speed (amber light – Figure 8) but can change to full speed or off (no lights) depending on the reheat capacity required. During high reheat, the 7 1/2 and 10 ton models must operate the OFMC at full speed to prevent excessive head pressure on system 2.

**Table 4: OFMC Factory Settings**

Unit	Setpoint
090	90°F
102	90°F
120	94°F
150	87°F

**Figure 8: OFMC Unit**

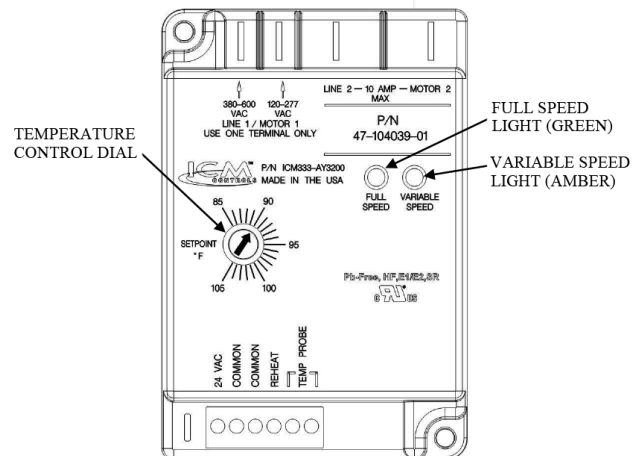

# Gas Supply, Condensate Drain

## Gas Connection

**⚠ DANGER**

Never test for gas leaks with an open flame. It can cause an explosion or fire resulting in property damage, personal injury or death. Use a commercially available soap solution made specifically for the detection of leaks to check all connections as specified in the "Mechanical Installation" section of these instructions.

**IMPORTANT:** Connect this unit only to gas supplied by a commercial utility.

1. Install gas piping in accordance with local codes and regulations of the local utility company. In the absence of local codes, the installation must conform to the specifications of the National Fuel Gas Code, ANSI Z223.1 - latest edition.

**NOTE:** The use of flexible gas connectors is not permitted.

2. Connect the gas line to the gas valve supplied with unit. Routing can be through the gas pipe opening shown in [Figure 10](#) or through the base as shown in [Figure 13](#) on page 14.
3. Size the gas line to the furnace adequate enough to prevent undue pressure drop and never less than 1/2".
4. Install a drip leg or sediment trap in the gas supply line as close to the unit as possible.
5. Install an outside ground joint union to connect the gas supply to the control assembly at the burner tray.
6. Gas valves have been factory installed. Install a manual gas valve where local codes specify a shut-off valve outside the unit casing ([Figure 9](#)).
7. Make sure piping is tight. A pipe compound resistant to the action of liquefied petroleum gases must be used at all threaded pipe connections.
8. **IMPORTANT:** Any additions, changes or conversions required for the furnace to satisfactorily meet the application should be made by a qualified installer, service agency or the gas supplier, using factory-specified or approved parts. In the commonwealth of Massachusetts, installation must be performed by a licensed plumber or gas fitter for appropriate fuel.

**Figure 9: Backup Wrench Location**

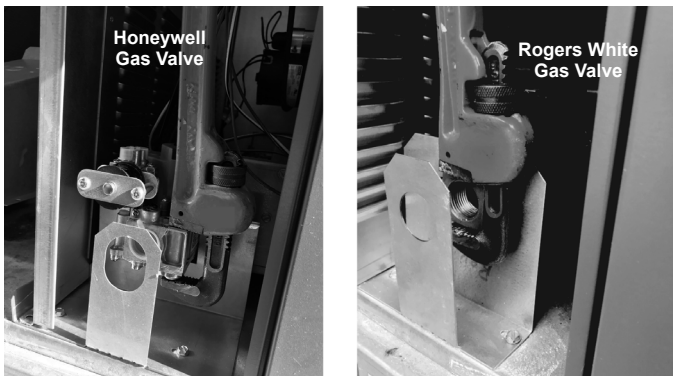

**Figure 10: Suggested Gas Piping**

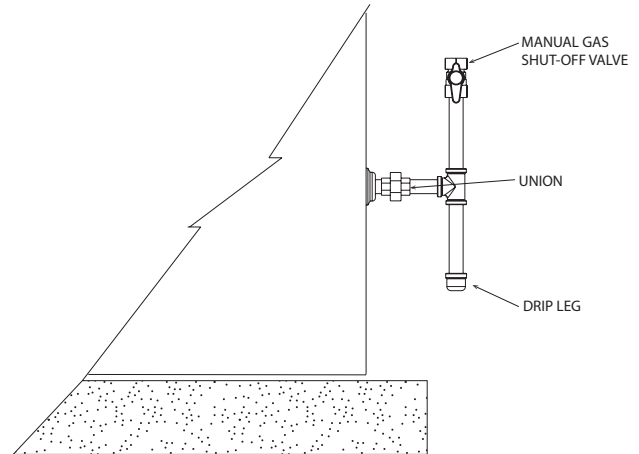

**IMPORTANT:**

Disconnect the furnace and its individual shutoff valve from the gas supply piping during any pressure testing of that system at test pressures in excess of 1/2 pound per square inch gauge or isolate the system from the gas supply piping system by closing its individual manual shutoff valve during any pressure testing of this gas supply system at pressures equal to or less than 1/2 PSIG.

Check the rating plate to make certain the unit is equipped to burn the type of gas supplied. Care should be taken after installation of this equipment that the gas control valve not be subjected to high gas supply line pressure. In making gas connections, avoid strains as they may cause noise and damage the controls. A backup wrench is required to be used on the valve to avoid damage.

**Table 5: Gas Pipe Capacity Table (Cu. Ft./Hr.)**

Nominal Iron Pipe Size	Equivalent Length of Pipe, Feet							
	10	20	30	40	50	60	70	80
1/2"	132	92	73	63	56	50	46	43
3/4"	278	190	152	130	115	105	96	90
1"	520	350	285	245	215	195	180	170
1 1/4"	1,050	730	590	500	440	400	370	350
1 1/2"	1,600	1,100	890	760	670	610	560	530

The capacities of gas pipe of different diameters and lengths in cu.ft. per hr. with pressure drop of 0.3 in. and specific gravity of 0.60 (natural gas) are shown in [Table 5](#).

After determining the pipe length, select the pipe size which will provide the minimum cubic feet per hour required for the gas input rating of the furnace. By formula:

$$\text{Cu. Ft. per Hr. Required} = \frac{\text{Gas Input of Furnace (BTU/Hr)}}{\text{Heating Value of Gas (BTU/Ft}^3\text{)}}$$

The gas input of the furnace is marked on the furnace rating plate. The heating value of the gas (BTU/Ft<sup>3</sup>) may be determined by consulting the local natural gas utility or the LP gas supplier.

## LP Conversion

**⚠ DANGER**

This unit is equipped at the factory for use with natural gas only. Conversion to LP gas requires a special kit supplied by the distributor or manufacturer. Mailing addresses are listed on the furnace rating plate, parts list and warranty. Failure to use the proper conversion kit can cause fire, carbon monoxide poisoning, explosion, personal injury, property damage, or death.

Convert the unit to use liquefied petroleum (LP) gas by replacing with the gas valve supplied in the conversion kit.

The LP gas valve maintains the proper manifold pressure for LP gas. The correct burner LP orifices are included in the kit.

**IMPORTANT:** To remove the natural gas valve, remove the four screws securing the manifold pipe to the burner tray. Remove the manifold pipe with gas valve attached.

**NOTE:** Order the correct LP conversion kit from the furnace manufacturer. See Conversion Kit Index shipped with unit for proper LP kit number. Furnace conversion to LP gas must be performed by a qualified technician.

## Adjusting or Checking Furnace Input

**Table 6: Line Pressure by Gas Type**

Gas Type	Line Pressure (in wc)	Manifold Pressure
Natural Gas	5 – 10.5	3.5
LP Gas	11–13	10

Supply and manifold pressure taps are located on the gas valve body 1/8" N.P.T. and on the manifold.

Use a properly calibrated manometer gauge for accurate gas pressure readings.

Only small variations in the gas flow should be made by means of the pressure regulator adjustment. Furnaces functioning on LP gas must be set by means of the tank or branch supply regulators. The furnace manifold pressure should be set at 10" W.C. at the gas control valve.

To adjust the pressure regulator, remove the regulator cap and turn the adjustment screw clockwise to increase pressure or counterclockwise to decrease pressure. **Then replace the regulator cap securely.**

Any necessary major changes in the gas flow rate should be made by changing the size of the burner orifices. To change orifice spuds, shut OFF the manual main gas valve and remove the gas manifold.

For elevations up to 2,000 feet, rating plate input ratings apply. For high altitudes (elevations over 2,000 ft.), contact Daikin Applied Parts. see conversion kit index 92-21519-XX for derating and orifice spud sizes.

Check of input is important to prevent over-firing of the furnace beyond its design-rated input. NEVER SET INPUT ABOVE THAT SHOWN ON THE RATING PLATE. Use the following table or formula to determine input rate.

$$\text{Cu. Ft. per Hr. Required} = \frac{\text{Heating Value of Gas (BTU/CuFt)} \times 3600}{\text{Time in Seconds for 1 Cu.Ft. of Gas}}$$

**Table 7: Meter Time in Minutes and Seconds for Normal Input Rating of Furnaces Using Natural or LP Gas**

Input Btu/ hr	Meter Size Cu .Ft .	Heating Value of Gas Btu Per Cu .Ft .								LP (cu. Ft.)	
		900		1000		1050		1100		2500	
		Minutes	Seconds	Minutes	Seconds	Minutes	Seconds	Minutes	Seconds	Minutes	Seconds
150,000	One	0	22	0	24	0	25	0	26	1	0
	Ten	3	36	4	0	1	16	4	24	10	0
205,000	One	0	16	0	18	0	18	0	19	0	44
	Ten	2	38	2	56	0	55	3	13	7	19
225,000	One	0	14	0	16	0	17	0	18	0	40
	Ten	2	24	2	40	0	50	2	56	6	40

**Table 8: LP Gas Pipe Capacity (Cubic feet per hour)**

Nominal Iron Pipe Size, Inches	Length of Pipe, Feet									
	10	20	30	40	50	60	70	80	90	100
½	275	189	152	129	114	103	96	89	83	78
¾	567	393	315	267	237	217	196	182	173	162
1	1,071	732	590	504	448	409	378	346	322	307
1¼	2,205	1,496	1,212	1,039	913	834	771	724	677	630
1½	3,307	2,299	1,858	1,559	1,417	1,275	1,181	1,086	1,023	976
2	6,221	4,331	3,465	2,992	2,646	2,394	2,205	2,047	1,921	1,811

Start the furnace and measure the time required to burn one cubic foot of gas. Prior to checking the furnace input, make certain that all other gas units are shut OFF, with the exception of pilot burners. Time the meter with only the furnace in operation.

**IMPORTANT NOTE FOR ALTITUDES ABOVE 2,000 FEET (610 METERS):** The main burner orifices in your furnace and in these kits are sized for the nameplate input and intended for installations at elevations up to 2,000 feet in the USA or Canada, or for elevations of 2,000 - 4,500 feet (610 1,373 meters) in Canada if the unit has been derated at the factory. For elevations above 2,000 feet (610 meters) **IN THE USA ONLY** (see ANSI Z223.1), the burner orifices must be sized to reduce the input 4% for each 1,000 feet (305 meters) above sea level.

**NOTICE:** Derating of the heating input for high altitude in the field is unlawful in Canada (refer to CAN/CGA 2.17). Units installed in altitudes greater than 2,000 feet (610 meters) must be shipped from the factory or from a factory authorized conversion station with the heating input derated by 10% so as to operate properly in altitudes from 2,000 - 4,500 feet (610 1,373 meters).

### Condensate Drain

The condensate drain connection of the evaporator is threaded ¾" nominal iron pipe. **IMPORTANT:** Install a condensate trap to ensure proper condensate drainage. See Figure 11.

**Figure 11: Condensate Drain**

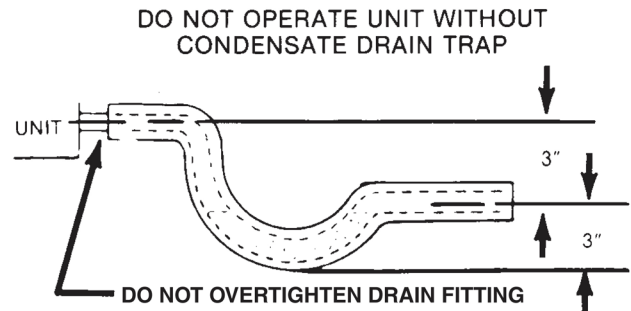

# Electrical Installation

## Power Supply

### DANGER

Power supply to the unit must be disconnected before making field connections. To avoid electrical shock, personal injury or death, be sure to rigorously adhere to field wiring procedures regarding proper lockout and tagout of components.

1. **All wiring should be made in accordance with the [National Electrical Code](#).** Consult the local power company to determine the availability of sufficient power to operate the unit. Check the voltage at power supply to make sure it corresponds to the unit's RATED VOLTAGE REQUIREMENT. Install a branch circuit disconnect near the rooftop, in accordance with the N.E.C., C.E.C. or local codes.
2. It is important that proper electrical power is available at the unit. Voltage should not vary more than 10% from that stamped on the unit nameplate. On three phase units, phases must be balanced within 3%.
3. For branch circuit wiring (main power supply to unit disconnect), the minimum wire size for the length of run can be determined from [Table 9](#) using the circuit ampacity found on the unit rating plate.
4. For through the base wiring entry reference [Figure 13](#). All fittings and conduit are field supplied for this application. Reference the chart with [Table 10](#) on page 14 for proper hole and conduit size.
5. For branch circuit wiring (main power supply to unit disconnect), the minimum wire size for the length of run can be determined from this table using the circuit ampacity found on the unit rating plate. From the unit disconnect to unit, the smallest wire size allowable in [Table 9](#) may be used, as the disconnect must be in sight of the unit.
6. Wire size based on 75°C rated wire insulation for 1% voltage drop.
7. For more than 3 conductors in a raceway or cable, see the N.E.C. (C.E.C. in Canada) for derating the ampacity of each conductor.

**IMPORTANT:** This unit is approved for use with copper conductors only connected to unit contactor. Warranty will be voided if aluminum wire is connected to unit contactor.

**Figure 12: Recommended Branch Circuit Disconnect Location**

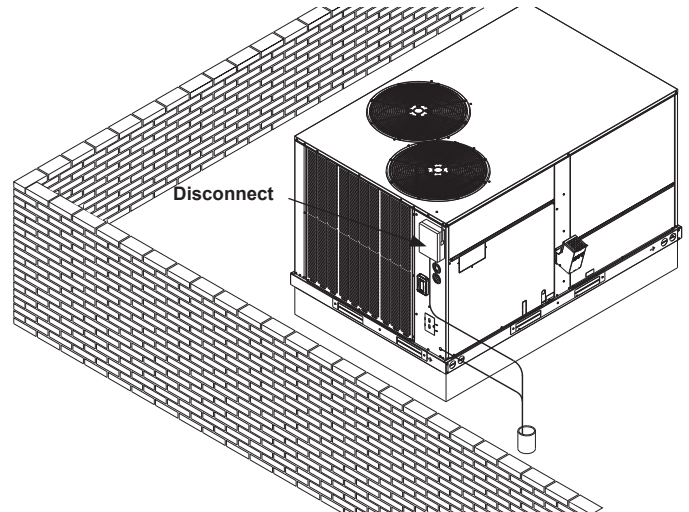

**Table 9: Minimum Wire Sizes**

Unit MCA	Supply Wire Length in Feet					
	50	100	150	200	250	300
20	10	8	6	4	4	4
25	10	8	6	4	4	3
30	8	6	4	4	3	2
35	8	6	4	3	2	1
40	8	6	4	3	2	1
45	8	4	3	2	1	1/0
50	6	4	3	2	1	1/0
60	6	4	2	1	1/0	2/0
70	4	3	2	1/0	2/0	3/0
80	4	3	1	1/0	2/0	3/0
90	3	2	1/0	2/0	3/0	4/0
100	3	2	1/0	2/0	3/0	4/0
110	2	1	2/0	3/0	4/0	250
125	1	1	2/0	3/0	4/0	25

Figure 13: Base Entry Locations

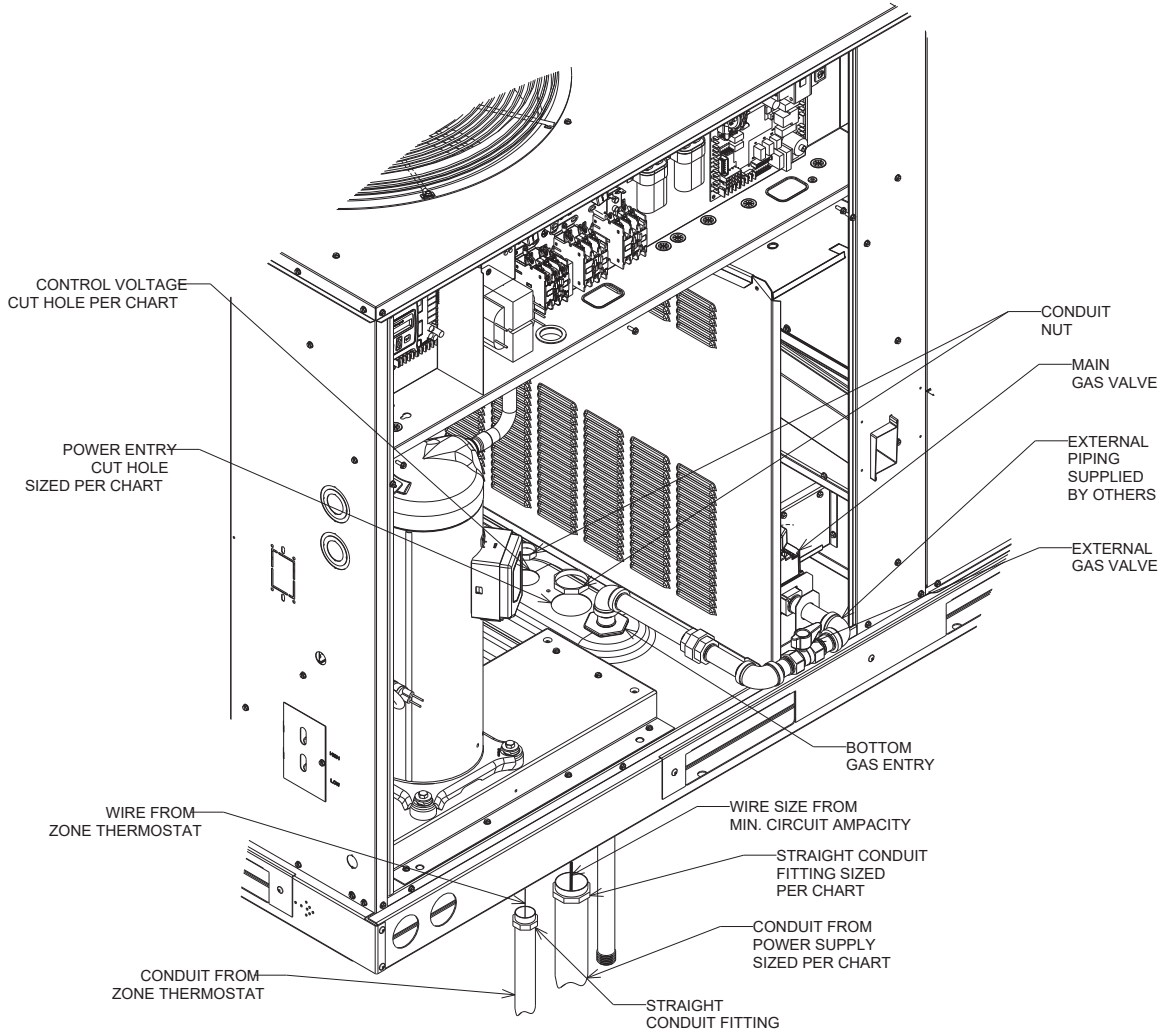

Table 10: Recommended Wire Sizes

Wire Size, AWG	14	12	10	8	6	4	3	2	1	0	00	000
Conduit Size	1/2"	1/2"	1/2"	3/4"	1"	1"	1-1/4"	1-1/4"	1-1/2"	1-1/2"	2"	2"
Hole Size	7/8"	7/8"	7/8"	1-31/32"	1-23/64"	1-23/64"	1-23/32"	1-23/32"	1-31/32"	1-31/32"	2-15/32"	2-15/32"

**Hook-Up**

To wire unit, refer to the following hook-up diagram. Refer to [Figure 13](#) and [Figure 35 on page 56](#) for location of wiring entrances. Wiring to be done in the field between the unit and devices not attached to the unit, or between separate devices which are field installed and located, shall conform with the temperature limitation for Type T wire [63°F rise (35°C)] when installed in accordance with the manufacturer’s instructions.

**Internal Wiring**

A diagram of the internal wiring of this unit is located on the inside of control access panel and in this manual. If any of the original wire as supplied with the unit must be replaced, the wire gauge and insulation must be same as original wiring.

**208 Volt Applications**

Transformer is factory wired for 230 volts on 208/230 volt models and must be changed for 208 volt applications. See unit wiring diagram for 208 volt wiring.

## Customer Supplied Thermostat

The customer supplied room thermostat must be compatible with the spark ignition control on the unit. Generally, all thermostats that are not of the “current robbing” type are compatible with the integrated furnace control. The low voltage wiring should be sized as shown in [Table 11](#).

**Table 11: Field Wire Size for 24 Volt Thermostat**

Thermostat Load Amps	Solid Copper Wire, AWG					
	16	14	12	10	10	10
3.0	16	14	12	10	10	10
2.5	16	14	12	12	10	10
2.0	18	16	14	12	12	10
	50	100	150	200	250	300
	Length of Run — Feet (1)					

**NOTE:**

(1) The total wire length is the distance from the furnace to the thermostat and back to the furnace.

DO NOT USE CONTROL WIRING SMALLER THAN NO. 18 AWG.

Install the room thermostat in accordance with the instruction sheet packed in the box with the thermostat.

See [Figure 15 on page 16](#) for an example of a typical customer supplied wiring diagram.

## Optional Factory Supplied Thermostat

The optional factory supplied, touch screen, commercial setback digital thermostat ([Figure 14](#)) uses microcomputer technology to provide precise time and temperature control. This thermostat offers the flexibility to design heating and cooling programs that fit building needs ([Table 12](#)). This thermostat is adaptable to most residential 24 volt forced air multi-stage systems with electric or fossil fuel auxiliary and is the ultimate for comfort, convenience, and performance.

See [Figure 16 on page 16](#) for an optional factory supplied thermostat wiring diagram.

**Figure 14: Optional Thermostat**

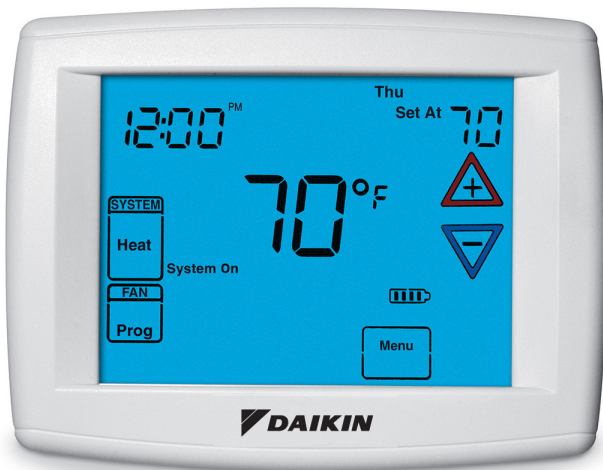

**Table 12: Optional Factory Supplied Thermostat Specifications**

Electrical Rating Single Stage:	mV to 30 V (ac), NEC Class II, 50/60 Hz or DC
Electrical Rating Staging:	20 to 30 V (ac), NEC Class II
Terminal Load:	1.5 A per terminal, 2.5 A max. combined
Setpoint Range:	45° to 99°F (7° to 37°C)
Anticipation, Heating:	Adjustable
Anticipation, Cooling:	Adjustable
Rated Differential Single Stage:	Heat 0.6°F, Cool 1.2°F
Rated Differential Staging:	Heat 0.6°F, Cool 1.2°F
Operating Ambient:	32° to +105°F (0° to +41°C)
Operating Humidity:	90% non-condensing max.
Shipping Temperature Range:	-4° to 150°F (-20° to 65°C)
Dimensions (H x W x D):	4.6" x 5.9" x 1.2"

**Table 13: Thermostat Terminal Functions**

Y2	2nd Stage Compressor
Y	Compressor Relay
G	Fan Relay
RC	Power for Cooling
RH	Power for Heating
C	Common wire from secondary side of cooling (Optional). Required for fault indication, continuous backlight operation or remote temperature sensor operation
L	Malfunction indicator for systems with malfunction connection
W/E	Heat Relay/Emergency Heat Relay (Stage 1)
W2	2nd Stage Heat (3rd Stage Heat in HP2)
Blank	Blank
-	Common (DC) for wired remote temperature sensor
S	Frequency signal from remote temperature sensor
+	Power (DC) to remote temperature sensor

# Wiring Diagrams

Figure 15: Typical Customer Supplied Thermostat Wiring Diagram

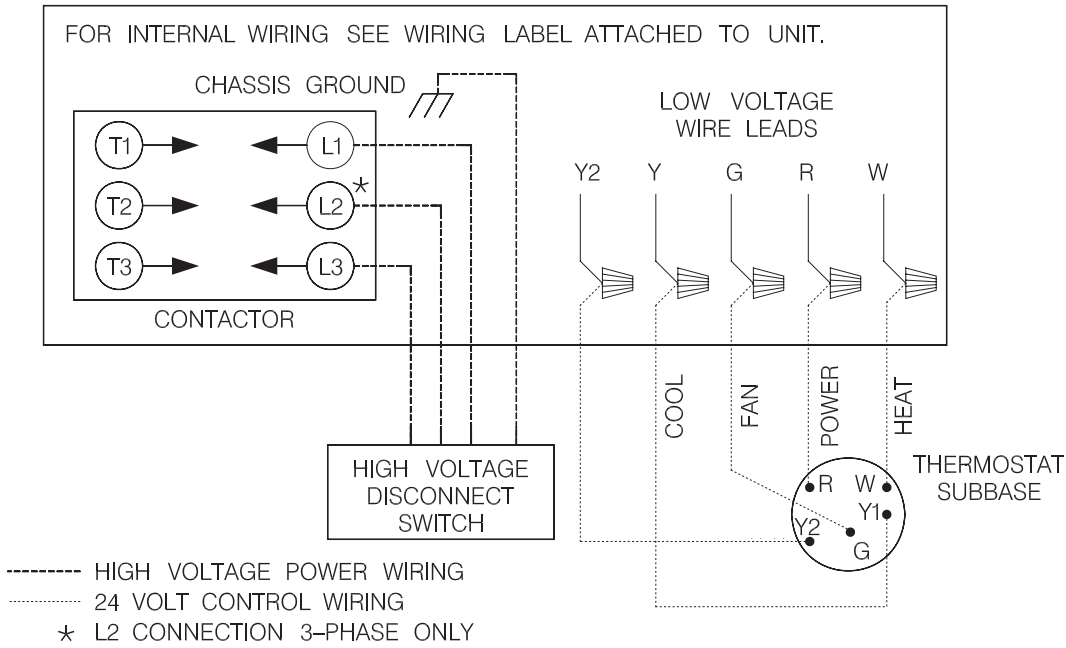
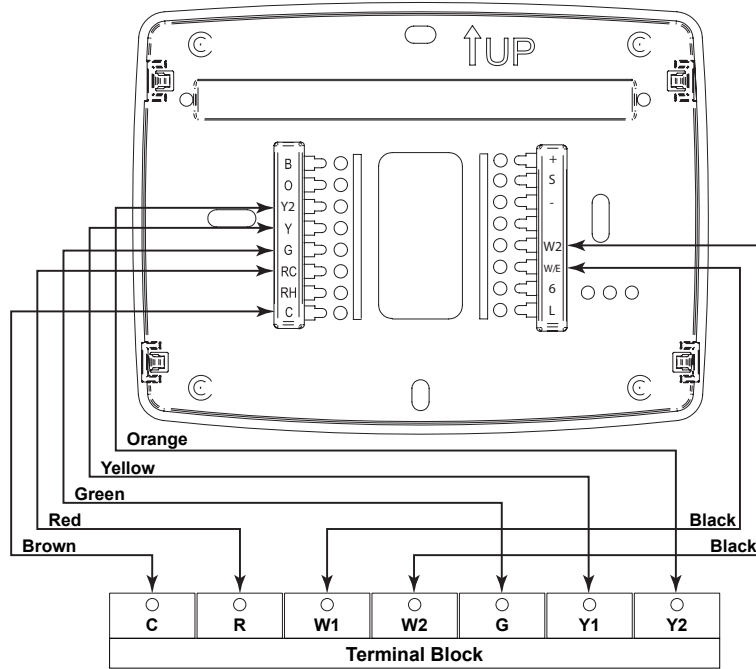

Figure 16: Optional Factory Supplied 7-170 Thermostat Wiring Diagram



1. On 3 to 5 ton units, a terminal block is not supplied. Use a wirenut to extend from the leads provided in the unit to the thermostat. W1, W2, and Y2 are optional depending upon the size and selected options of the unit. Colors shown above are typical for the MPS I.
2. For wiring with DDC control option, see [OM 1077](#) for wiring instructions.

Figure 17: MPS 012D, 208-230/460 Volt (Constant Volume Gas Heat — Electromechanical Controls)

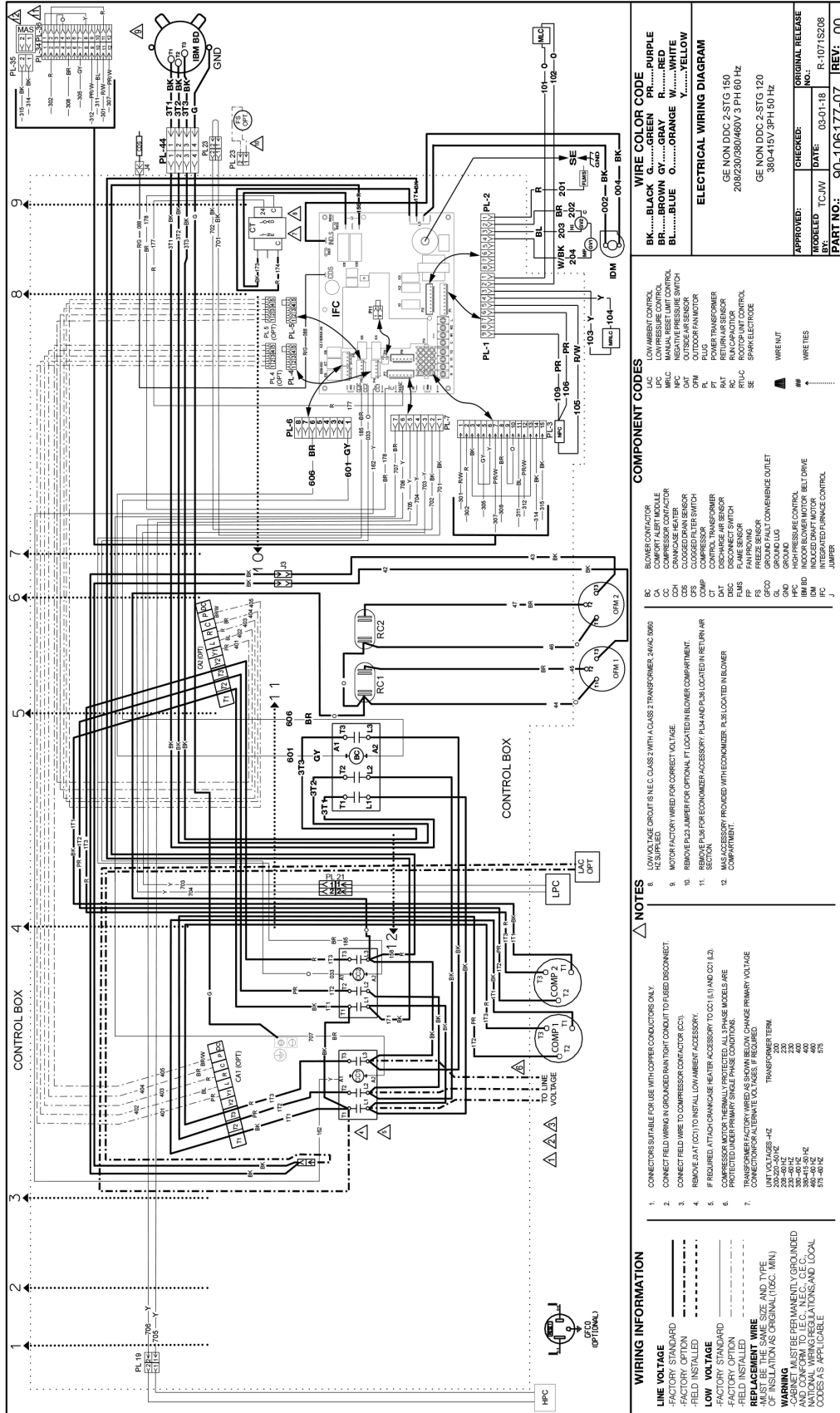
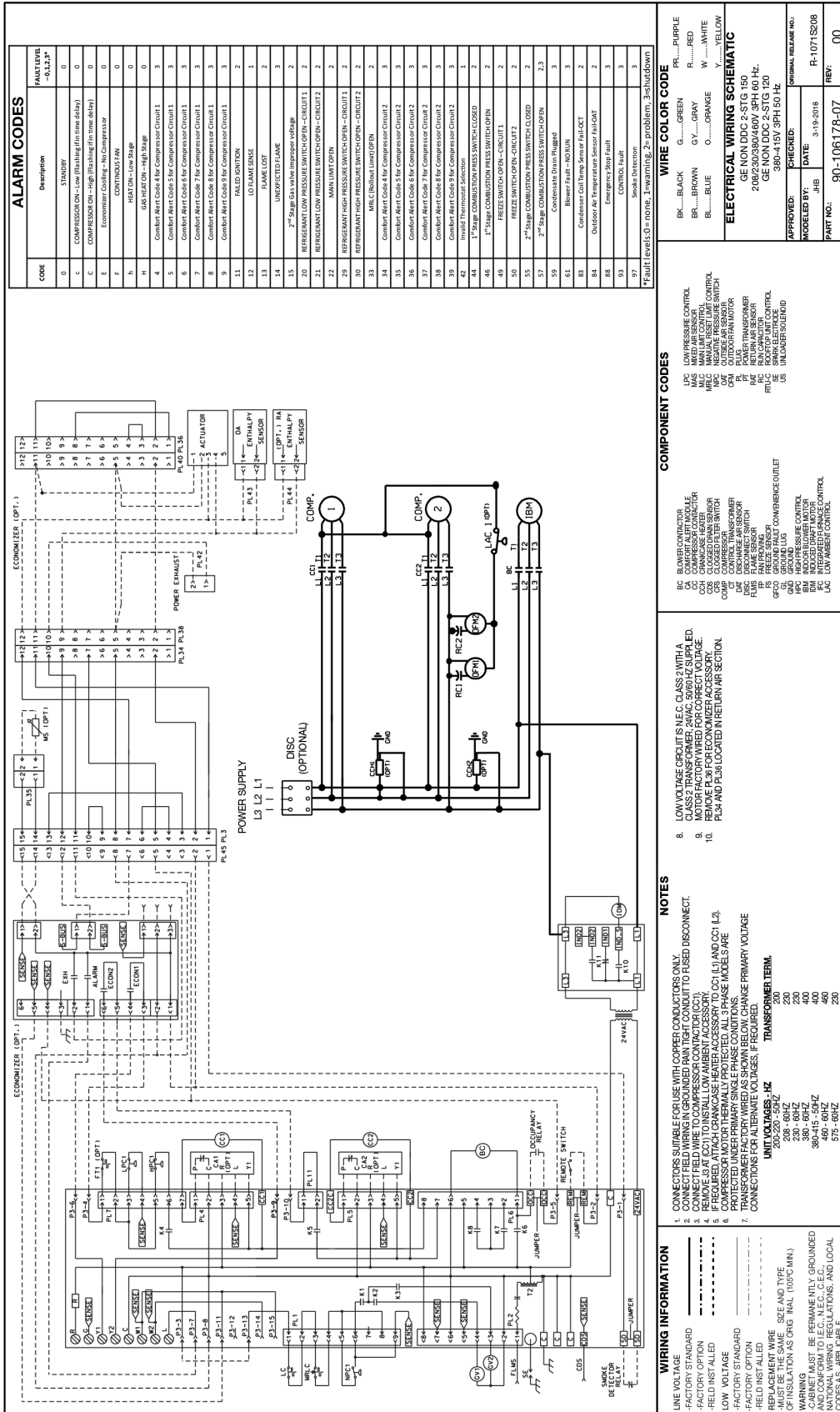

Figure 17 continued: MPS 012D, 208-230/460 Volt (Constant Volume Gas Heat — Electromechanical Controls)



ALARM CODES		FAULT LEVEL
CODE	Description	-0,1,2,3*
0	STANDBY	0
B	COMPRESSION-LOW (Flashing for time delay)	0
C	COMPRESSION-HIGH (Flashing for time delay)	0
E	Economizer Coasting - No Compressor	0
F	CONTINUOUS FAN	0
G	HATON - Low Stage	0
H	HATON - High Stage	0
4	Combiner Alert Code 4 for Compressor Circuit 1	3
5	Combiner Alert Code 5 for Compressor Circuit 1	3
6	Combiner Alert Code 6 for Compressor Circuit 1	3
7	Combiner Alert Code 7 for Compressor Circuit 1	3
8	Combiner Alert Code 8 for Compressor Circuit 1	3
9	Combiner Alert Code 9 for Compressor Circuit 1	3
11	FAILED IGNITION	2
12	ID FLAME SENSE	2
13	FLAME LOST	2
14	UNEXPECTED FLAME	3
15	2 <sup>nd</sup> Stage Coil Valve Inoperative without	2
20	REFRIGERANT LOW PRESSURE SWITCH OPEN - CIRCUIT 1	2
21	REFRIGERANT LOW PRESSURE SWITCH OPEN - CIRCUIT 2	2
22	MANUAL LIMIT OPEN	2
29	REFRIGERANT HIGH PRESSURE SWITCH OPEN - CIRCUIT 1	2
30	REFRIGERANT HIGH PRESSURE SWITCH OPEN - CIRCUIT 2	2
33	MISC (Bubble Limit) OPEN	3
34	Combiner Alert Code 4 for Compressor Circuit 2	3
35	Combiner Alert Code 5 for Compressor Circuit 2	3
36	Combiner Alert Code 6 for Compressor Circuit 2	3
37	Combiner Alert Code 7 for Compressor Circuit 2	3
38	Combiner Alert Code 8 for Compressor Circuit 2	3
39	Combiner Alert Code 9 for Compressor Circuit 2	3
42	Invalid Thermostat Selection	1
44	1 <sup>st</sup> Stage COMBUSTION PRESS SWITCH CLOSED	2
46	1 <sup>st</sup> Stage COMBUSTION PRESS SWITCH OPEN	2
49	FREEZE SWITCH OPEN - CIRCUIT 1	2
50	FREEZE SWITCH OPEN - CIRCUIT 2	2
55	2 <sup>nd</sup> Stage COMBUSTION PRESS SWITCH CLOSED	2
57	2 <sup>nd</sup> Stage COMBUSTION PRESS SWITCH OPEN	2,3
59	Condensate Drain Plugged	3
61	Blower Fault - NO RUN	3
83	Condenser Coil Temp Sensor Fail-OUT	2
84	Outdoor Air Temperature Sensor Fail-OUT	2
88	Emergency Stop Fault	3
93	CONTROL Fault	3
97	Smoke Detection	3

WIRE COLOR CODE		WIRE COLOR CODE	
Color	Code	Color	
Black	BL	Green	G
Brown	BR	Gray	GR
Blue	BLU	Orange	O
White	W	Yellow	Y

ELECTRICAL WIRING SCHEMATIC	
GE NON DDC 2-STG 150	
208/230/460/460V 3PH 60 Hz	
GE NON DDC 2-STG 120	
380-415V 3PH 50 Hz	

APPROVED:	DATE:	ORIGINAL RELEASE NO.:
_____	3-19-2018	PR-107152008

COMPONENT CODES	
LPC	LOW PRESSURE CONTROL
M/C	MANUAL LIMIT CONTROL
MSC	NEGATIVE PRESSURE SWITCH
OUT	OUTSIDE AIR SENSOR
PL	PLUMBING TRANSDUCER
PLU	PLUMBING TRANSDUCER
RA	RETURN AIR SENSOR
RAU	RETURN AIR SENSOR
RTUC	ROOM THERMISTOR CONTROL
US	UNPLUGGED SOLID

NOTES	
1.	CONNECTORS SUITABLE FOR USE WITH COPPER CONDUCTORS ONLY.
2.	CONNECT FELD WIRE TO GROUND IN RAIN TIGHT CONDUIT TO FUSED DISCONNECT.
3.	CONNECT FELD WIRE TO COMPRESSOR CONTACTOR (CCT).
4.	IF REQUIRED, ATTACH CRANKCASE HEATER ACCESSORY TO CCT (L1) AND CCT (L2).
5.	IF REQUIRED, ATTACH CRANKCASE HEATER ACCESSORY TO CCT (L3) AND CCT (L4).
6.	COMPRESSOR MOTOR THERMALLY PROTECTED. ALL 3-PHASE MODELS ARE THERMALLY PROTECTED.
7.	TRANSFORMER FACTORY WIRING IS SHOWN BELOW. CHANGE PRIMARY VOLTAGE CONNECTIONS FOR ALTERNATE VOLTAGES, IF REQUIRED.

WIRING INFORMATION	
LINE VOLTAGE	208-230-594HZ
FACTORY STANDARD	230-60HZ
FACTORY OPTION	380-60HZ
REPLACEMENT WIRE	380-415-594HZ
WIRING	575-60HZ

TRANSFORMER TERM.	
200	
220	
230	
400	
460	
480	
575	

NOTES	
8.	LOW VOLTAGE CIRCUIT IS N.E.C. CLASS 2 WITH A CLASS 2 TRANSFORMER. 2WAG, 5000 HZ SUPPLIED.
9.	MOTOR FACTORY WIRING FOR CORRECT VOLTAGE. REMOVE FUSE FOR ECONOMIZER ACCESSORY.
10.	PUSH AND PULL LOCATED IN THE UNIT SECTION.

WIRING INFORMATION	
FACTORY STANDARD	---
FACTORY OPTION	---
REPLACEMENT WIRE	---
WIRING	---







Figure 19 continued: MPS 007-010D, 208-230/460 Volt (Two-Speed SAF Gas Heat — Electromechanical Controls)

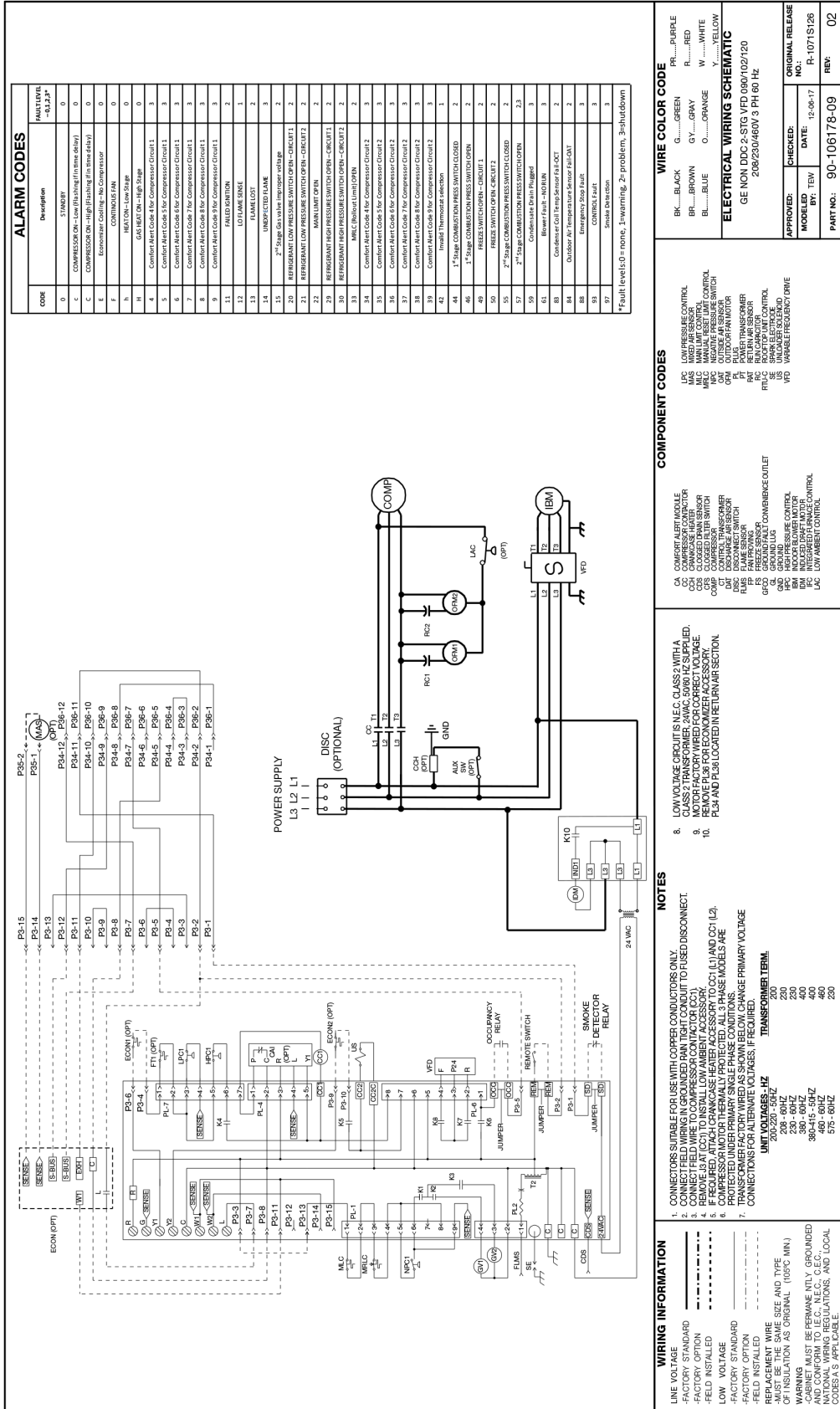
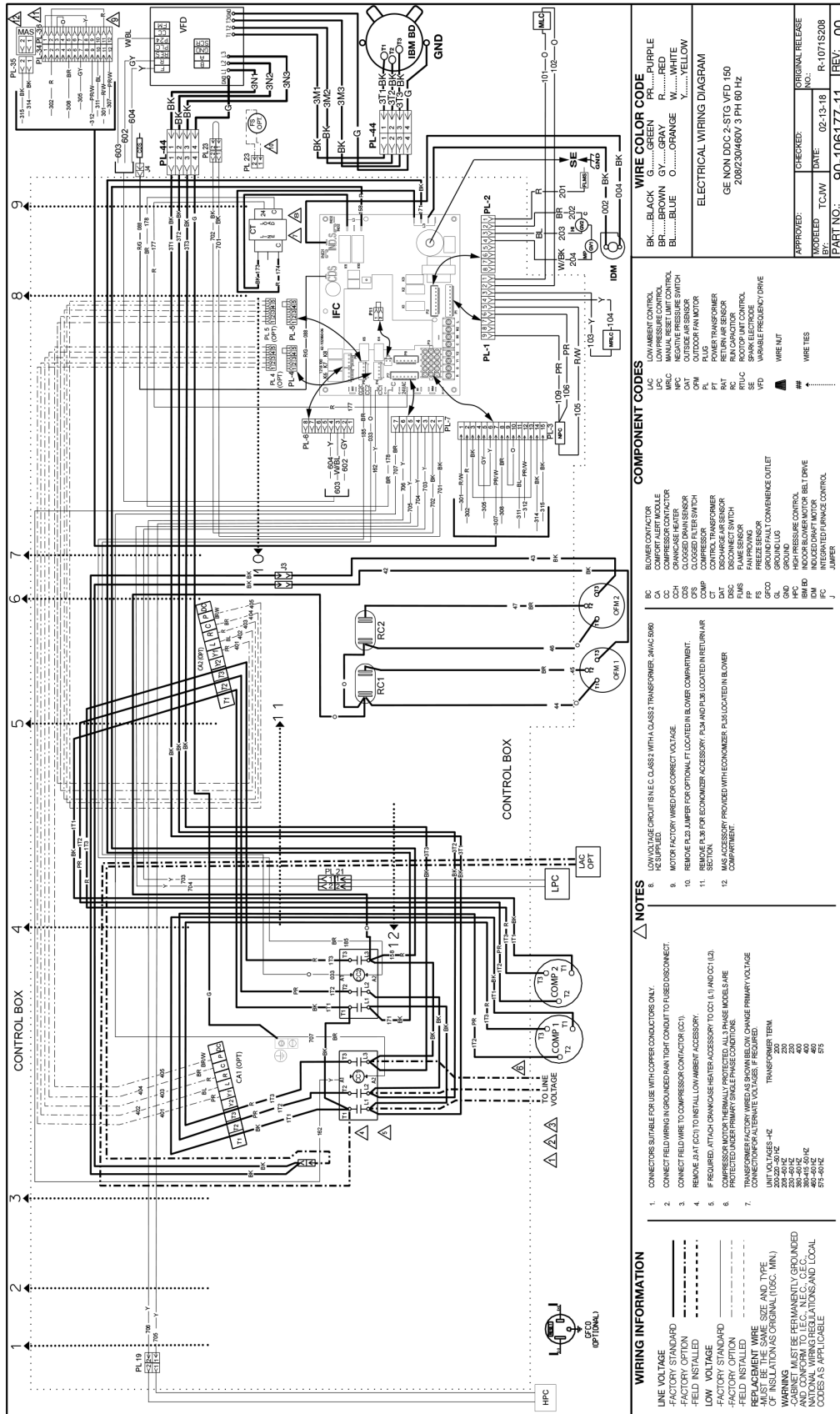

Figure 20: MPS 012D, 208-230/460 Volt (Two-Speed SAF Gas Heat — Electromechanical Controls)



**WIRE COLOR CODE**  
 BK.....BLACK G.....GREEN PR.....PURPLE  
 BR.....BROWN GV.....GRAY R.....RED  
 BL.....BLUE O.....ORANGE V.....VIOLET  
 Y.....YELLOW

**ELECTRICAL WIRING DIAGRAM**  
 GE NON DDC 2 STGS VFD 150  
 208/230/460V 3 PH 60 HZ

**COMPONENT CODES**  
 LUC LOW AMBIENT CONTROL  
 MFC MANUAL RESET LIMIT CONTROL  
 NPS NEGATIVE PRESSURE SWITCH  
 OPM OUTDOOR FAN MOTOR  
 PL PLUG  
 PFM FAN MOTOR  
 RBT RETURN AIR SENSOR  
 RLC RETURN AIR LIMIT CONTROL  
 RUC RETURN AIR UNIT CONTROL  
 RUC RETURN AIR UNIT CONTROL  
 VFD VARIABLE FREQUENCY DRIVE  
 WIRE NUT  
 WIRE TIE

**NOTES**  
 1. CONNECTORS SUITABLE FOR USE WITH COPPER CONDUCTORS ONLY.  
 2. CONNECT FIELD WIRING IN GROUND/RAN TIGHT CONDUIT TO FUSED DISCONNECT.  
 3. CONNECT FIELD WIRE TO COMPRESSOR CONTACTOR (CCT).  
 4. REMOVE JUMP FOR ECONOMIZER ACCESSORY. FLOW AND FLOW LOCATED IN BLOWER COMPARTMENT.  
 5. IF REQUIRED, ATTACH CRANKCASE HEATER ACCESSORY TO CCL, L1 AND CCL1 (L3).  
 6. COMPRESSOR MOTOR THERMALLY PROTECTED. ALL 3 PHASE ACCESSORIES ARE PROTECTED UNDER PRIMARY SINGLE PHASE CONDITIONS.  
 7. TRANSFORMER FACTORY WIRING AS SHOWN BELOW CHANGE PRIMARY VOLTAGE CONNECTIONS TO ALTERNATE VOLTAGES, IF REQUIRED.  
 TRANSFORMER TAP  
 208-230V 460V  
 230-240V 480V  
 240-250V 500V  
 250-260V 525V

**WIRING INFORMATION**  
 LINE VOLTAGE  
 -FACTORY OPTION  
 -FIELD INSTALLED  
 LOW VOLTAGE  
 -FACTORY STANDARD  
 -FACTORY OPTION  
 -FIELD INSTALLED  
 MUST BE THE SAME SIZE AND TYPE OF INSULATION AS ORIGINAL (100% MIN.)

**WARNING**  
 WIRING MUST BE PERMANENTLY GROUNDING AND CONFORM TO I.E.C., N.E.C., C.E.C. NATIONAL WIRING REGULATIONS AND LOCAL CODES AS APPLICABLE.

**APPROVED:** \_\_\_\_\_ **CHECKED:** \_\_\_\_\_ **ORIGINAL RELEASE**  
**DATE:** 02-13-18 **IND.:** R-1071S208  
**BY:** TCJW **REV:** 00  
**PART NO.:** 90-106177-11

Figure 20 continued: MPS 012D, 208-230/460 Volt (Two-Speed SAF Gas Heat — Electromechanical Controls)

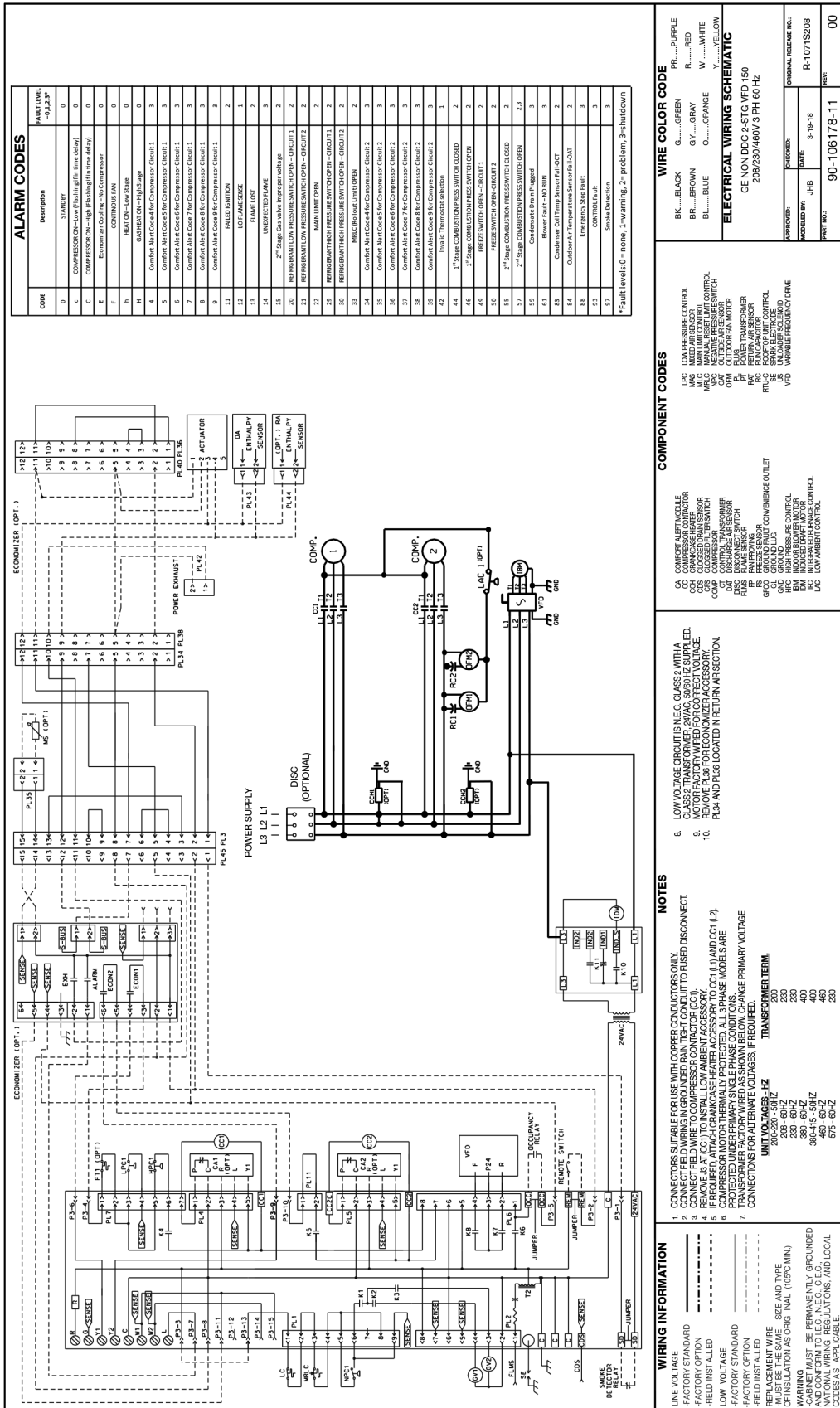



Figure 21 continued: MPS 007-010D, 208-230/460 Volt (Two-Speed SAF Gas Heat — DDC Controls)

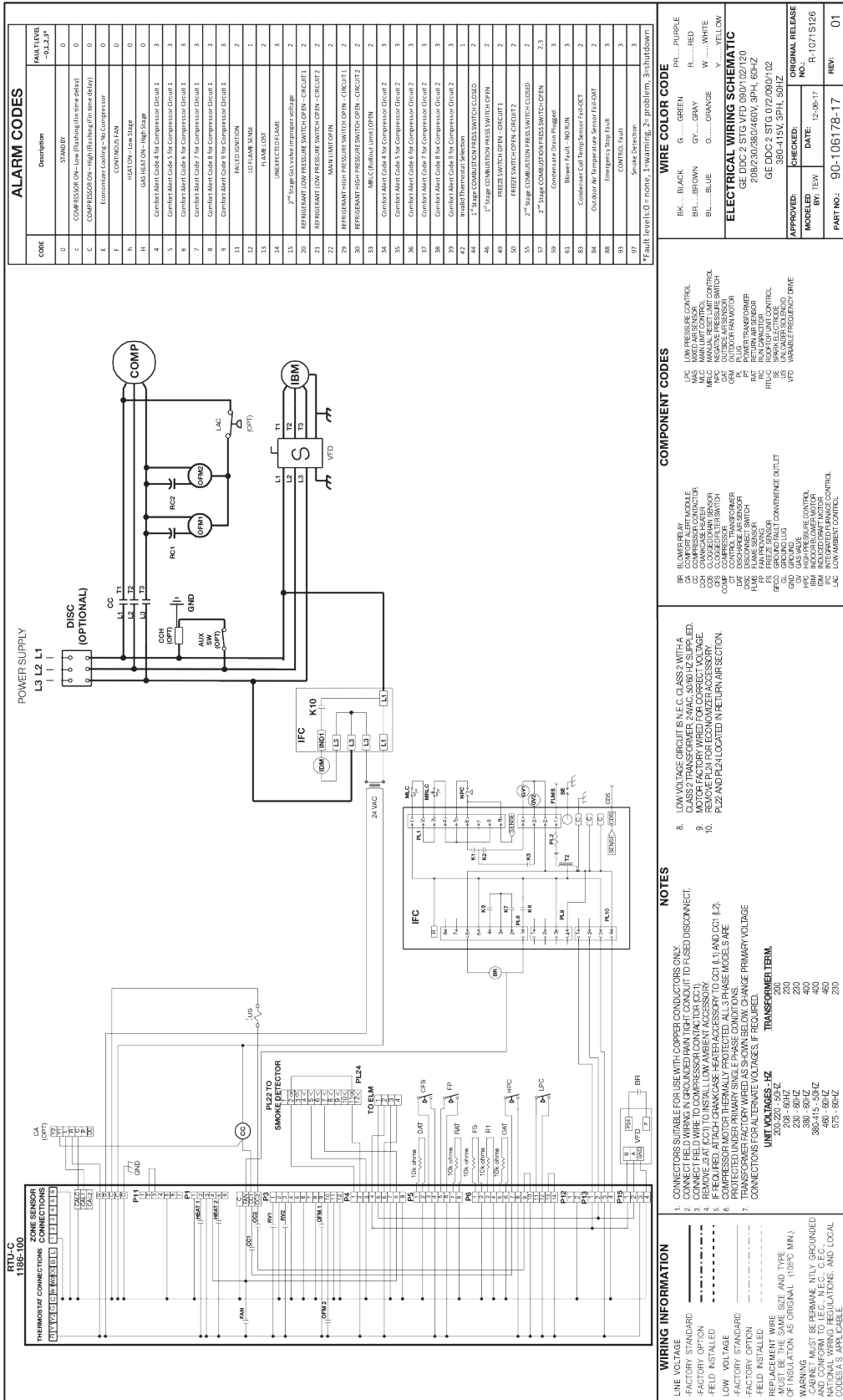
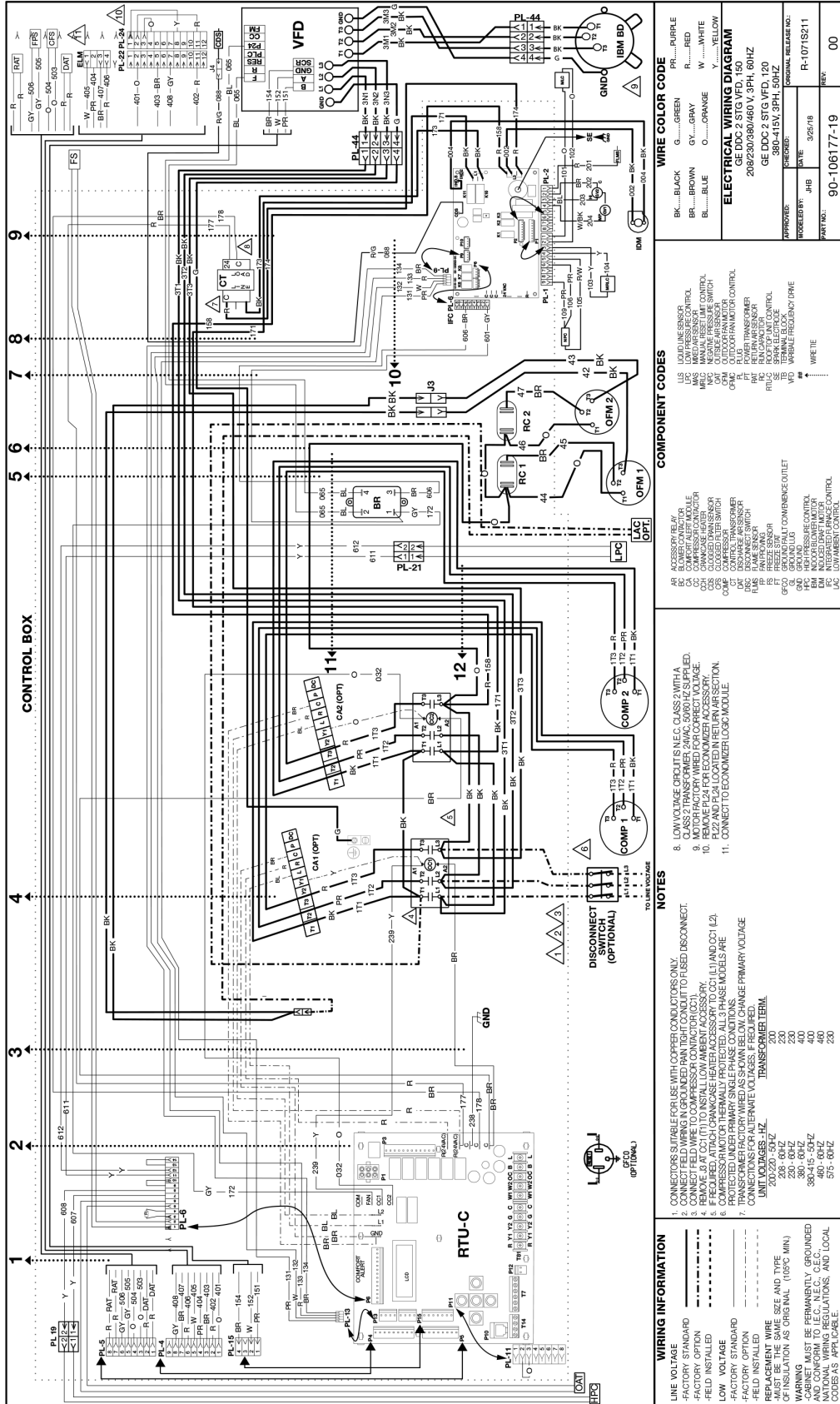

Figure 22: MPS 012D, 208-230/460 Volt (Two-Speed SAF Gas Heat — DDC Controls)



**WIRING INFORMATION**

LINE VOLTAGE: ————  
 FACTORY OPTION: - - - - -  
 FIELD INSTALLED: - · - · - · -  
 LOW VOLTAGE: - - - - -  
 FACTORY STANDARD: ————  
 FIELD INSTALLED: - · - · - · -  
 WIRE GROUNDING: ————  
 WIRE SIZE AND TYPE: ————  
 WIRE INSULATION: ————  
 WIRE COLOR CODE: ————  
 WIRE RELEASE NO.: ————

**WIRING INFORMATION**

1. CONNECTORS SUITABLE FOR USE WITH COPPER CONDUCTORS ONLY.  
 2. CONNECT FIELD WIRE TO COMPRESSOR CONDUIT TO FIELD DISCONNECT.  
 3. REMOVE J-BAT (T) TO INSTALL LOW AMBIENT ACCESSORY.  
 4. COMPRESSOR MOTOR THERMALLY PROTECTED. ALL 3 PHASE MODELS ARE PROTECTED UNDER PRIMARY SINGLE PHASE CONDITIONS.  
 5. CONNECTIONS FOR ALTERNATE WIRING TO BE MADE FROM USER'S TRANSFORMER TERMINAL.  
 UNIT VOLTAGES - HZ TRANSFORMER TERMINAL  
 200-220-50/4Z 200  
 208-208-4Z 220  
 230-208-4Z 230  
 380-415-50/4Z 400  
 380-415-50/4Z 400  
 575-50/4Z 480  
 575-50/4Z 230

**NOTES**

8. LOW VOLTAGE CIRCUITS N.E.C. CLASS 2 WITH A LIMITED VOLTAGE.  
 9. MOTOR FACTORY WIRING FOR CORRECT VOLTAGE.  
 10. REMOVE J-BAT FOR ECONOMIZER ACCESSORY.  
 11. P22 AND P24 LOCATED IN RETURN AIR SECTION.  
 11. CONNECT TO ECONOMIZER LOGIC MODULE.

**COMPONENT CODES**

US ACCESSORY BY  
 BC BLOWER CONTACTOR  
 CC COMPRESSOR CONTACTOR  
 CH CHANGEOVER SWITCH  
 CLS CLOSURE SWITCH  
 CT CENTRAL TRANSFORMER  
 DS DISCONNECT SWITCH  
 FV FAN FLOW SWITCH  
 FR FREEZE SENSOR  
 GND GROUND  
 INDOOR INDOOR AIR FLOW  
 INT INTEGRATED SPACE CONTROL  
 LAC LOW AMBIENT CONTROL

**WIRE COLOR CODE**

BK...BLACK  
 BR...BROWN  
 BL...BLUE  
 G...GREEN  
 GR...GRAY  
 O...ORANGE  
 PH...PURPLE  
 R...RED  
 W...WHITE  
 Y...YELLOW

**ELECTRICAL WIRING DIAGRAM**

208/230/460V, 3PH, 60HZ  
 GE DDC 2 STG. VFD, 120  
 380-415V, 3PH, 50/4Z

APPROVED: \_\_\_\_\_  
 MODEL BY: JHB DATE: 3/25/19  
 PART NO.: 90-106177-19 REV: 00



Figure 23: MPS 007-010D, 208-230/460 Volt (Constant Volume — Electromechanical Controls)

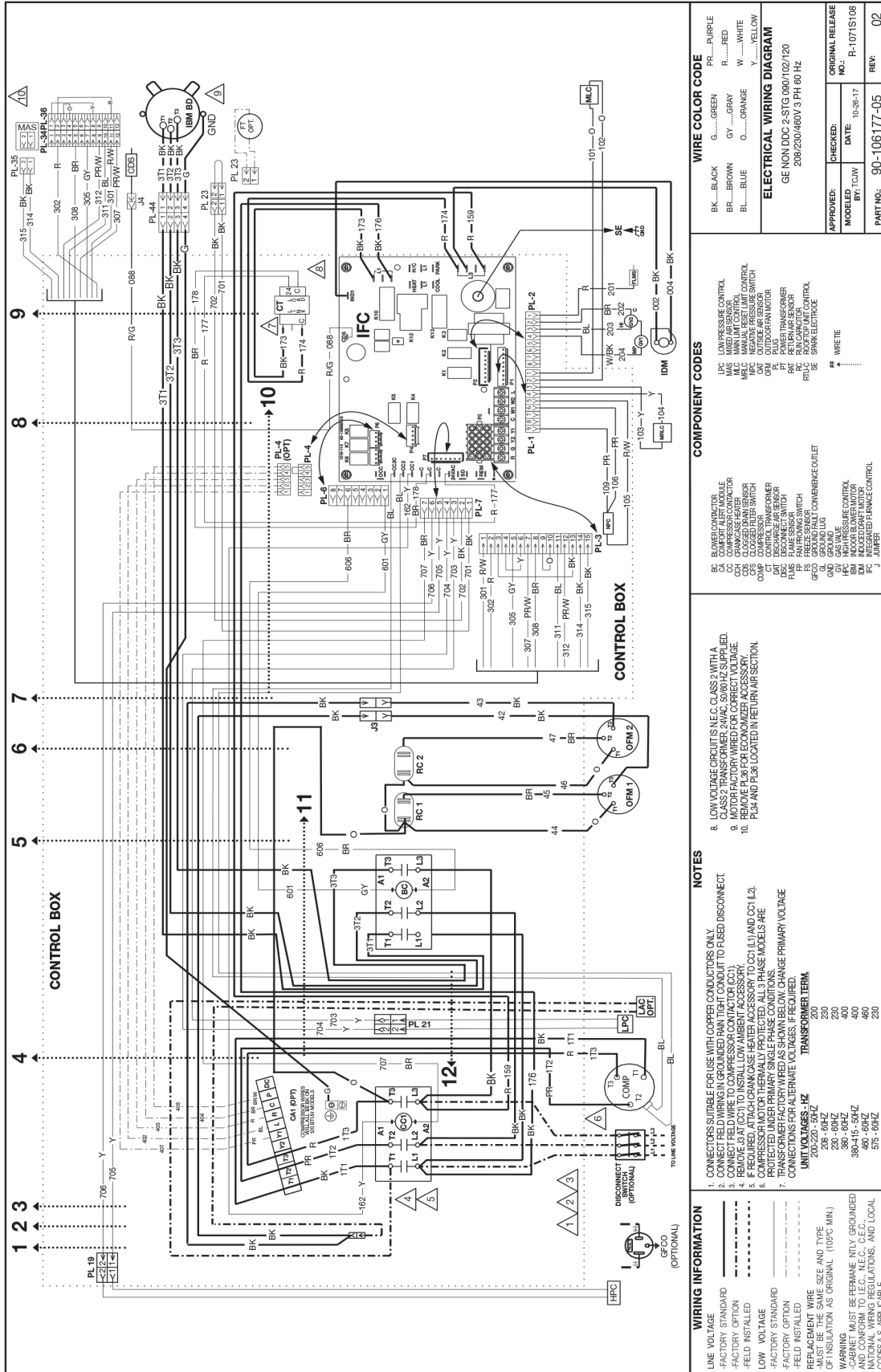

WIRE COLOR CODE		ORIGINAL RELEASE	
BK.....BLACK	G.....GREEN	PR.....PURPLE	NO: R-1071S108
BR.....BROWN	GY.....GRAY	R.....RED	DATE: 10-25-17
BL.....BLUE	O.....ORANGE	W.....WHITE	APPROVED: BY: TCW
Y.....YELLOW			CHECKED: 10-25-17

ELECTRICAL WIRING DIAGRAM	
GE NON DDC 2-STG 090/102/120 208/230/460V 3 PH 60 HZ	
MODELED BY: TCW	DATE: 10-25-17
APPROVED: BY: TCW	CHECKED: 10-25-17
PART NO: 90-106177-05	REV: 02

COMPONENT CODES	
BA	BLUVER SWITCHES
BC	COMPRESSOR CONTACTOR
CC	CONDENSER FAN MOTOR
CS	CONDENSER FAN SWITCH
CS2	CONDENSER FAN SWITCH
CS3	CONDENSER FAN SWITCH
CS4	CONDENSER FAN SWITCH
CS5	CONDENSER FAN SWITCH
CS6	CONDENSER FAN SWITCH
CS7	CONDENSER FAN SWITCH
CS8	CONDENSER FAN SWITCH
CS9	CONDENSER FAN SWITCH
CS10	CONDENSER FAN SWITCH
CS11	CONDENSER FAN SWITCH
CS12	CONDENSER FAN SWITCH
CS13	CONDENSER FAN SWITCH
CS14	CONDENSER FAN SWITCH
CS15	CONDENSER FAN SWITCH
CS16	CONDENSER FAN SWITCH
CS17	CONDENSER FAN SWITCH
CS18	CONDENSER FAN SWITCH
CS19	CONDENSER FAN SWITCH
CS20	CONDENSER FAN SWITCH
CS21	CONDENSER FAN SWITCH
CS22	CONDENSER FAN SWITCH
CS23	CONDENSER FAN SWITCH
CS24	CONDENSER FAN SWITCH
CS25	CONDENSER FAN SWITCH
CS26	CONDENSER FAN SWITCH
CS27	CONDENSER FAN SWITCH
CS28	CONDENSER FAN SWITCH
CS29	CONDENSER FAN SWITCH
CS30	CONDENSER FAN SWITCH
CS31	CONDENSER FAN SWITCH
CS32	CONDENSER FAN SWITCH
CS33	CONDENSER FAN SWITCH
CS34	CONDENSER FAN SWITCH
CS35	CONDENSER FAN SWITCH
CS36	CONDENSER FAN SWITCH
CS37	CONDENSER FAN SWITCH
CS38	CONDENSER FAN SWITCH
CS39	CONDENSER FAN SWITCH
CS40	CONDENSER FAN SWITCH
CS41	CONDENSER FAN SWITCH
CS42	CONDENSER FAN SWITCH
CS43	CONDENSER FAN SWITCH
CS44	CONDENSER FAN SWITCH
CS45	CONDENSER FAN SWITCH
CS46	CONDENSER FAN SWITCH
CS47	CONDENSER FAN SWITCH
CS48	CONDENSER FAN SWITCH
CS49	CONDENSER FAN SWITCH
CS50	CONDENSER FAN SWITCH
CS51	CONDENSER FAN SWITCH
CS52	CONDENSER FAN SWITCH
CS53	CONDENSER FAN SWITCH
CS54	CONDENSER FAN SWITCH
CS55	CONDENSER FAN SWITCH
CS56	CONDENSER FAN SWITCH
CS57	CONDENSER FAN SWITCH
CS58	CONDENSER FAN SWITCH
CS59	CONDENSER FAN SWITCH
CS60	CONDENSER FAN SWITCH
CS61	CONDENSER FAN SWITCH
CS62	CONDENSER FAN SWITCH
CS63	CONDENSER FAN SWITCH
CS64	CONDENSER FAN SWITCH
CS65	CONDENSER FAN SWITCH
CS66	CONDENSER FAN SWITCH
CS67	CONDENSER FAN SWITCH
CS68	CONDENSER FAN SWITCH
CS69	CONDENSER FAN SWITCH
CS70	CONDENSER FAN SWITCH
CS71	CONDENSER FAN SWITCH
CS72	CONDENSER FAN SWITCH
CS73	CONDENSER FAN SWITCH
CS74	CONDENSER FAN SWITCH
CS75	CONDENSER FAN SWITCH
CS76	CONDENSER FAN SWITCH
CS77	CONDENSER FAN SWITCH
CS78	CONDENSER FAN SWITCH
CS79	CONDENSER FAN SWITCH
CS80	CONDENSER FAN SWITCH
CS81	CONDENSER FAN SWITCH
CS82	CONDENSER FAN SWITCH
CS83	CONDENSER FAN SWITCH
CS84	CONDENSER FAN SWITCH
CS85	CONDENSER FAN SWITCH
CS86	CONDENSER FAN SWITCH
CS87	CONDENSER FAN SWITCH
CS88	CONDENSER FAN SWITCH
CS89	CONDENSER FAN SWITCH
CS90	CONDENSER FAN SWITCH
CS91	CONDENSER FAN SWITCH
CS92	CONDENSER FAN SWITCH
CS93	CONDENSER FAN SWITCH
CS94	CONDENSER FAN SWITCH
CS95	CONDENSER FAN SWITCH
CS96	CONDENSER FAN SWITCH
CS97	CONDENSER FAN SWITCH
CS98	CONDENSER FAN SWITCH
CS99	CONDENSER FAN SWITCH
CS100	CONDENSER FAN SWITCH

- NOTES**
- CONNECTORS SUITABLE FOR USE WITH COPPER CONDUCTORS ONLY.
  - CONNECT FIELD WIRING IN GROUNDED RAIN TIGHT CONDUIT TO FUSED DISCONNECT.
  - REMOVE BATTERY FROM COMPRESSOR CONTACTOR (CCT).
  - REMOVE BATTERY FROM CONDENSER FAN MOTOR ACCESSORY.
  - REMOVE BATTERY FROM CONDENSER FAN MOTOR ACCESSORY.
  - COMPRESSOR MOTOR THERMALLY PROTECTED. ALL 3 PHASE MODELS ARE PROTECTED UNDER PRIMARY SINGLE PHASE CONDITIONS.
  - TRANSFORMER FACTORY WIRING AS SHOWN BELOW. CHANGE PRIMARY VOLTAGE CONNECTIONS FOR ALTERNATE VOLTAGES, IF REQUIRED.
- | UNIT VOLTAGES - Hz | TRANSFORMER TAP |
|--------------------|-----------------|
| 208-0-208V/60Hz    | 230             |
| 230-0-230V/60Hz    | 230             |
| 380-0-380V/50Hz    | 400             |
| 460-0-460V/50Hz    | 460             |
| 575-0-575V/60Hz    | 230             |

WIRING INFORMATION	
LINE VOLTAGE	STANDARD
FACTORY OPTION	OPTIONAL
FIELD INSTALLED	OPTIONAL
LOW VOLTAGE	OPTIONAL
FACTORY OPTION	OPTIONAL
FIELD INSTALLED	OPTIONAL
REPLACEMENT WIRE	OPTIONAL
MUST BE THE SAME SIZE AND TYPE OF INSULATION AS ORIGINAL (100°C MIN)	OPTIONAL
WIRING MUST BE PERMANENTLY GROUNDED AND CONFORM TO I.E.C., N.E.C., C.E.C., NATIONAL WIRING REGULATIONS, AND LOCAL CODES AS APPLICABLE.	OPTIONAL





Figure 24 continued: MPS 012D, 208-230/460 Volt (Constant Volume Gas Heat — DDC Controls)

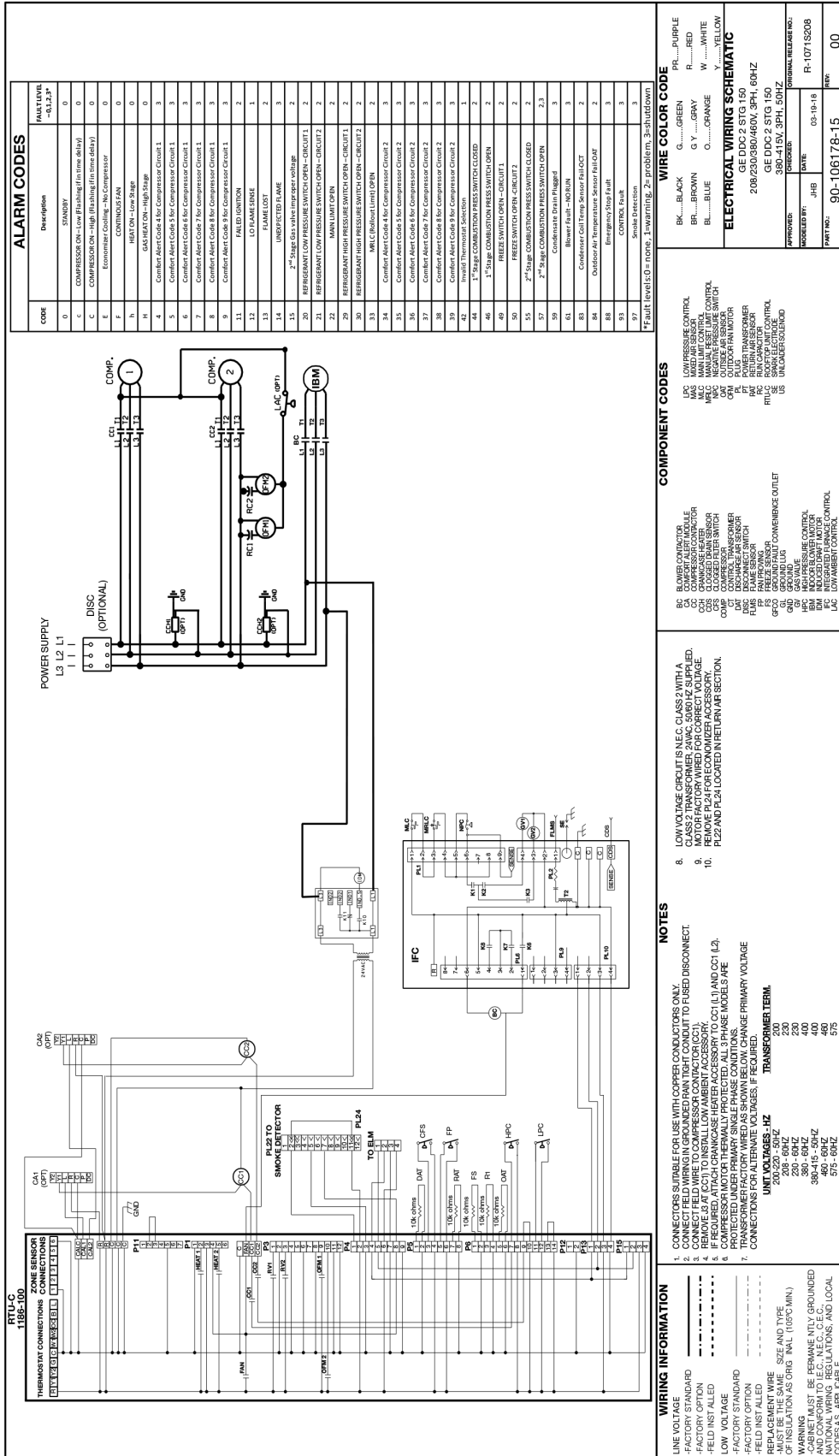
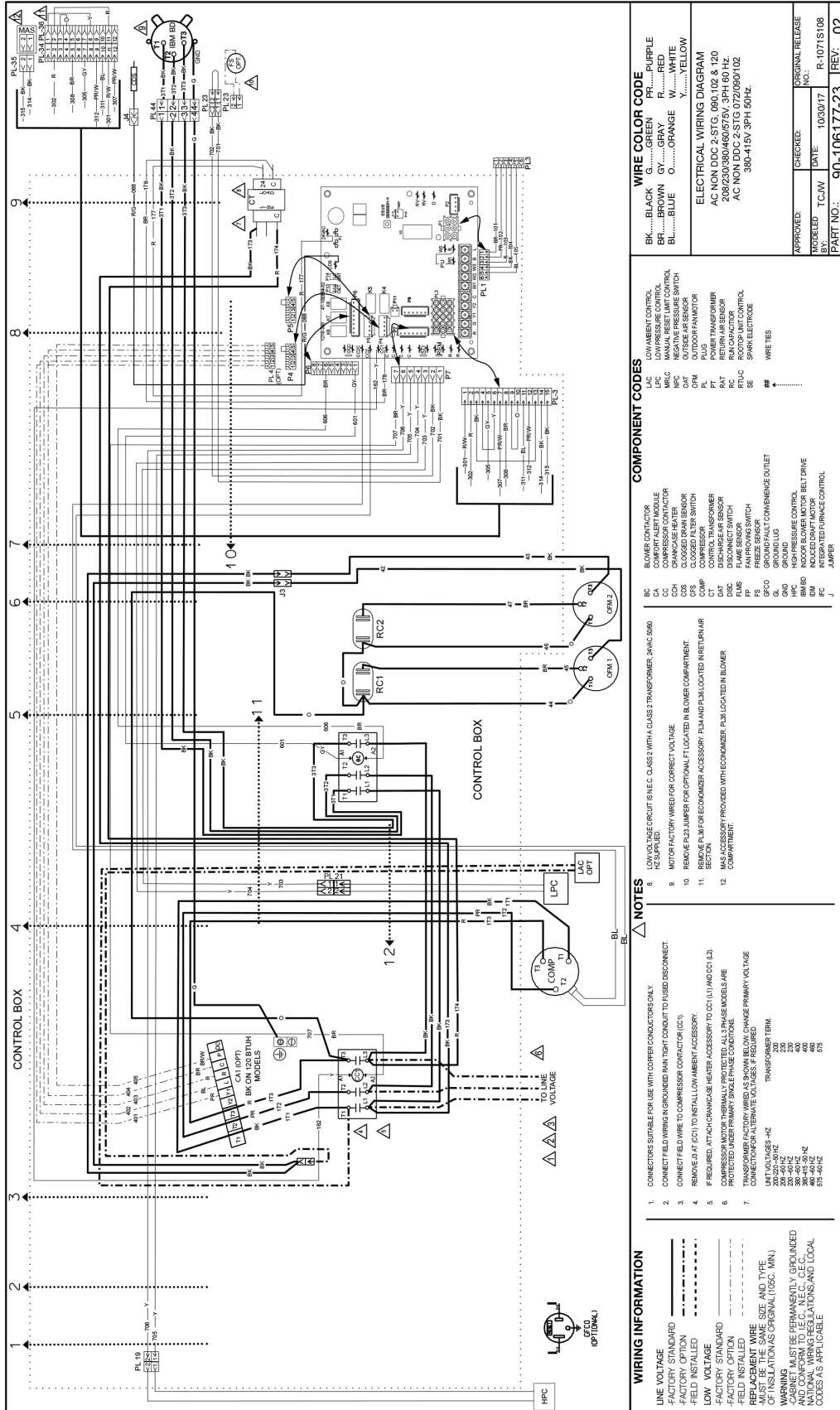

Figure 25: MPS 007-010D, 208-230/460 Volt (Constant Volume Cooling Only — Electromechanical Controls)



APPROVED:	CHECKED:	DATE:	10/20/17	ORIGINAL RELEASE
MODELED:	TCJW	BY:	RS-1071 S108	
PART NO.:	90-106177-23			REV: 02

WIRE COLOR CODE	PR.....PURPLE
BL.....BLUE	OR.....ORANGE
GR.....GREEN	WH.....WHITE
BR.....BROWN	Y.....YELLOW

COMPONENT CODES	DESCRIPTION
BA	BLOWER CONTACTOR
CC	COMPRESSOR CONTACTOR
CD	CLOSED DISCONNECT SWITCH
CFM	CONDENSER FAN MOTOR
EFM	EVAPORATOR FAN MOTOR
PL	PLUG
TR	TRANSFORMER
RA	RETURN AIR SENSOR
RC	ROOM AIR SENSOR
SE	SPARK ELECTRODE
W	WIRE TIES

NOTES	DESCRIPTION
1.	CONNECTORS SUITABLE FOR USE WITH COPPER CONDUCTORS ONLY.
2.	CONNECT FIELD WIRING IN GROUNDED RAIN TIGHT CONDUIT TO FIELD DISCONNECT.
3.	REMOVE Jumper AT (C1) TO INSTALL LOW AMBIENT ACCESSORY.
4.	REMOVE Jumper AT (C1) TO INSTALL LOW AMBIENT ACCESSORY.
5.	IF REQUIRED, ATTACH CRANKCASE HEATER ACCESSORY TO (C1) AND (C1L).
6.	COMPRESSOR MOTOR THERMALLY PROTECTED. ALL PHASE MODELS ARE PROTECTED UNDER PRIMARY SINGLE PHASE CONDITIONS.
7.	TRANSFORMER FACTORY WIRING AS SHOWN BELOW CHANGE PRIMARY VOLTAGE CONNECTIONS TO APPLICABLE VOLTAGE. IF REQUIRED.

WIRING INFORMATION	DESCRIPTION
LINE VOLTAGE	STANDARD
FACTORY OPTION	FIELD INSTALLED
LOW VOLTAGE	FACTORY STANDARD
FACTORY OPTION	FIELD INSTALLED
WIRING INFORMATION	DESCRIPTION
WIRING INFORMATION	DESCRIPTION

WIRING INFORMATION	DESCRIPTION
WIRING INFORMATION	DESCRIPTION
WIRING INFORMATION	DESCRIPTION

Figure 25 continued: MPS 007-010D, 208-230/460 Volt (Constant Volume Cooling Only — Electromechanical Controls)

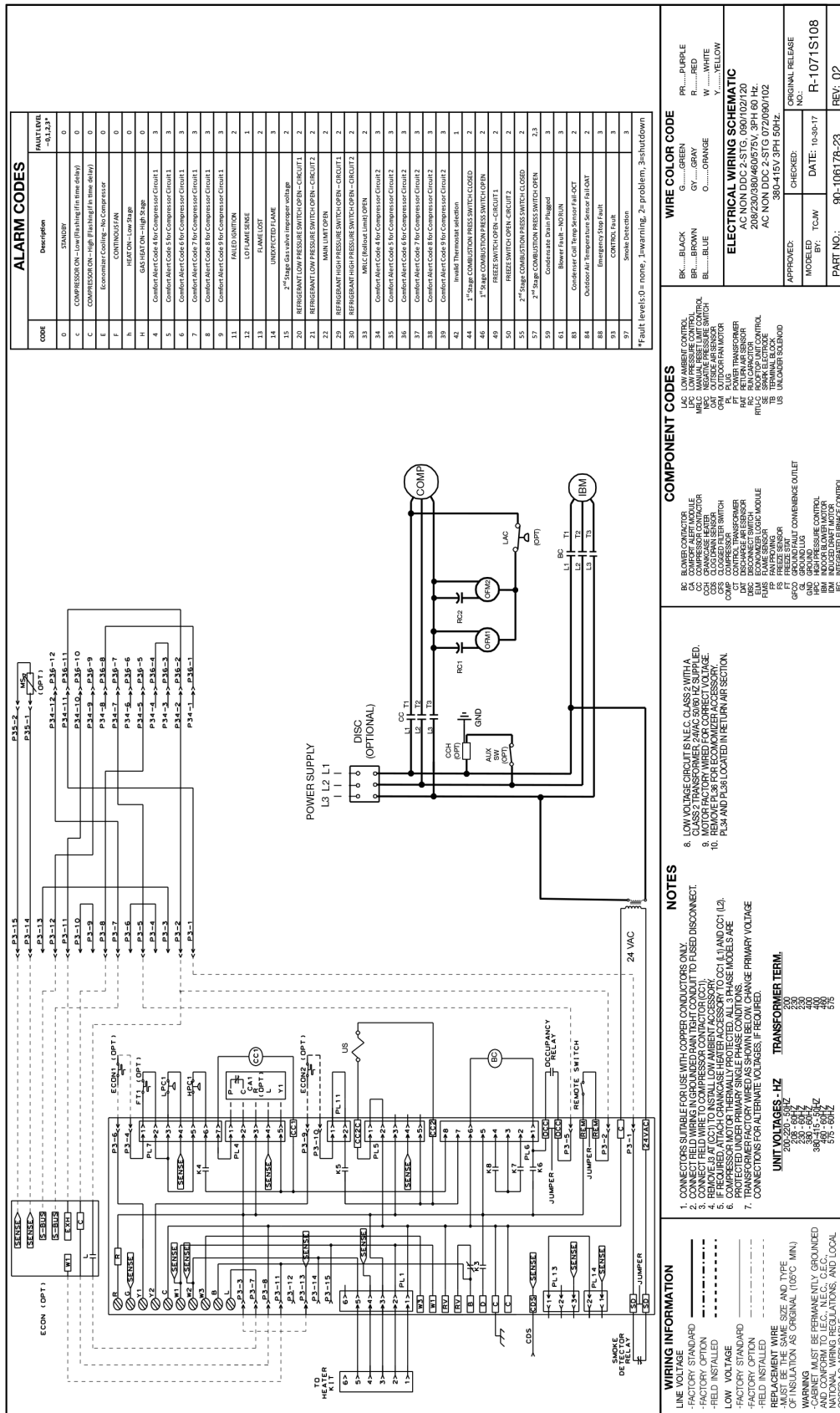

WIRE COLOR CODE	
BK.....BLACK	RL.....PURPLE
BR.....BROWN	R.....RED
BL.....BLUE	W.....WHITE
GY.....GRAY	Y.....YELLOW
OR.....ORANGE	

**ELECTRICAL WIRING SCHEMATIC**  
 AC NON DDC 2-STG. 090/102/120  
 200/230/260/460/975V, 3PH 60 HZ.  
 AC NON DDC 2-STG. 070/200/102

APPROVED:	CHECKED:	NO.:
MODEL:	DATE:	R-1071S108
PCAW	10-30-17	
PART NO.:	90-106178-23	REV: 02

- COMPONENT CODES**
- LC LOW PRESSURE CONTROL
  - LP LOW PRESSURE CONTROL
  - NSC NEGATIVE PRESSURE SWITCH
  - OR OR
  - ORV OUTDOOR AIR MOTOR
  - PL FAN MOTOR
  - PL TRANSFORMER
  - RAT RETURN AIR SENSOR
  - RTU ROOM THERMISTOR CONTROL
  - RTU ROOM THERMISTOR CONTROL
  - TB TERMINAL BLOCK
  - US UNLOAD/SOLENOID
- NOTES**
- LOW VOLTAGE CIRCUIT IS N.E.C. CLASS WITH A CLASSIFICATION OF 48V. IF SUPPLIED.
  - MOTOR FACTORY WIRING FOR CORRECT VOLTAGE.
  - REMOVE FUSE FOR ECONOMIZER ACCESSORY.
  - PLC AND FUSE LOCATED IN RETURN AIR SECTION.

- WIRING INFORMATION**
- LINE VOLTAGE
  - FACTORY STANDARD
  - FACTORY OPTION
  - FIELD INSTALLED
  - LOW VOLTAGE
  - FACTORY STANDARD
  - FACTORY OPTION
  - FIELD INSTALLED
  - REPLACEMENT WIRE
  - MUST BE THE SAME SIZE AND TYPE
  - OF INSULATION AS ORIGINAL (105°C MIN)
  - CABINET MUST BE PERMANENTLY GROUNDED
  - AND CONFORM TO I.E.C., N.E.C., C.E.C., C.A.S.I., REGULATIONS, AND LOCAL CODES AS APPLICABLE.
- TRANSFORMER TAP**
- | UNIT VOLTAGES, HZ   | TRANSFORMER TERM. |
|---------------------|-------------------|
| 200/230/260/460/975 | 200               |
| 230/260/460/975     | 230               |
| 260/460/975         | 260               |
| 460/975             | 460               |
| 975                 | 975               |

Figure 26: MPS 012D, 208-230/460 Volt (Constant Volume Cooling Only — Electromechanical Controls)

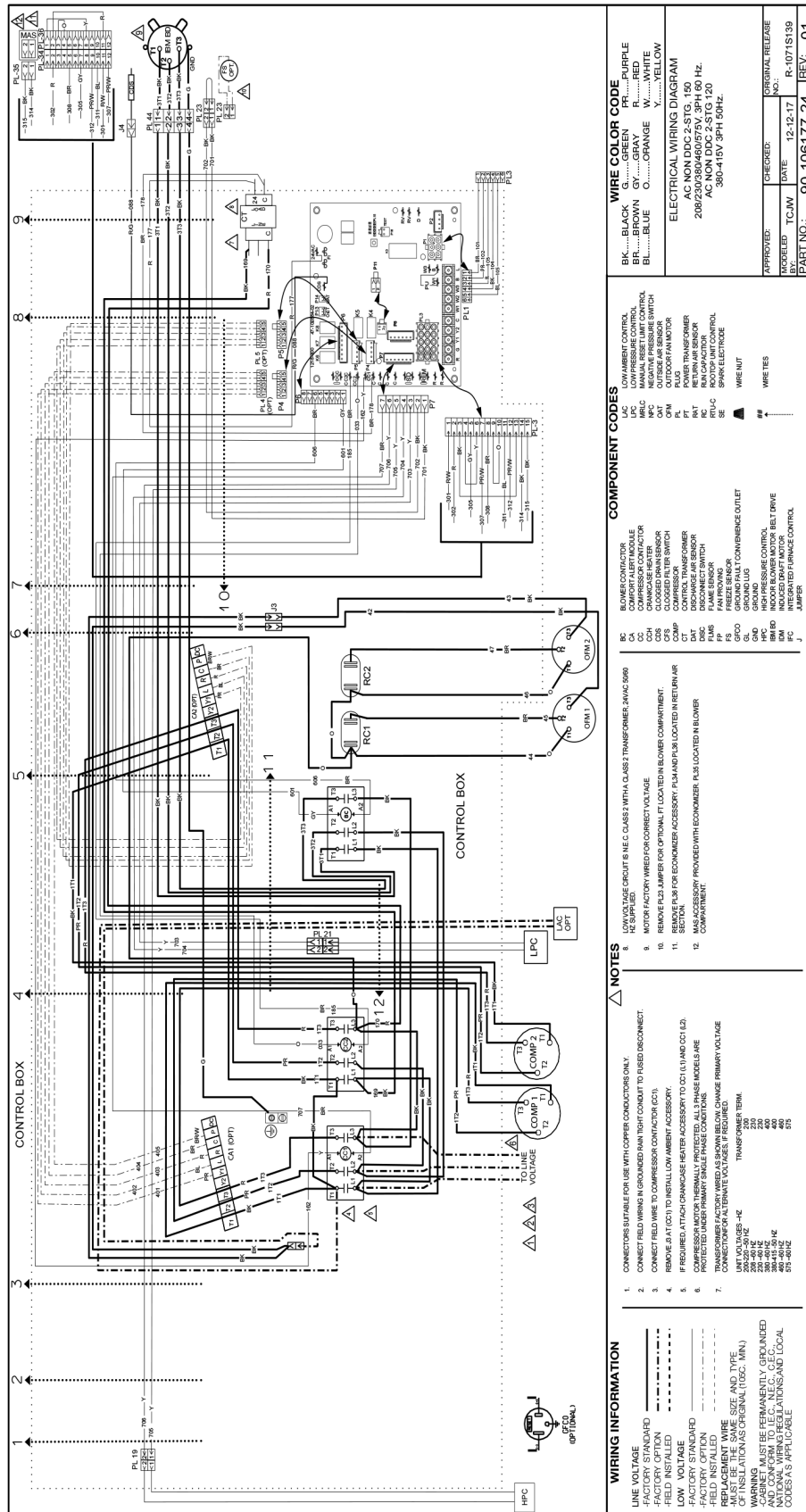

**WIRE COLOR CODE**

BK.....BLACK	G.....GREEN	FR.....PURPLE
BR.....BROWN	GR.....GRAY	W.....WHITE
BL.....BLUE	OR.....ORANGE	Y.....YELLOW

**ELECTRICAL WIRING DIAGRAM**

AC NON DDC 2-STG. 150  
208/230/380/460/575V. 3PH 60 Hz.  
AC NON DDC 2-STG 120  
380-410V 3PH 50Hz.

**APPROVED:** \_\_\_\_\_ **CHECKED:** \_\_\_\_\_ **ORIGINAL RELEASE**

**MODELED:** TCC:MW **DATE:** 12-12-17 **REV:** 01

**PART NO.:** 90-106177-24

**COMPONENT CODES**

LAC	LOW AMBIENT CONTROL
MALC	MANUAL RESET LIMIT CONTROL
MS	MOTOR
OUT	OUTDOOR AIR SENSOR
CFM	CONDENSER FAN MOTOR
PT	POWER TRANSFORMER
RET	RETURN AIR SENSOR
RTUAC	ROOM THERMISTOR UNIT CONTROL
SE	SPARK ELECTRODE
WIRE NUT	WIRE NUT
WIRE TIE	WIRE TIE

**NOTES**

- CONNECTORS SUITABLE FOR USE WITH COPPER CONDUCTORS ONLY.
- CONNECT FIELD WIRING IN GROUNDED MAIN TIGHT CONDUIT TO RIBBED DISCONNECT.
- REMOVE Jumper A1 (CCT1) TO INSTALL LOW AMBIENT ACCESSORY.
- IF REQUIRED, ATTACH CRANKCASE HEATER ACCESSORY TO CT1 (L1) AND CT1 (L2).
- COMPRESSOR MOTOR THERMALLY PROTECTED. ALL THREE MODELS ARE THERMALLY PROTECTED.
- TRANSFORMER FACTORY WIRING AS SHOWN BELOW. CHANGE PRIMARY VOLTAGE CONNECTIONS OR ALTERNATE VOLTAGES IF REQUIRED.

**WIRING INFORMATION**

LINE VOLTAGE: \_\_\_\_\_

FACTORY OPTION: \_\_\_\_\_

FIELD INSTALLED: \_\_\_\_\_

LOW VOLTAGE: \_\_\_\_\_

FACTORY OPTION: \_\_\_\_\_

FIELD INSTALLED: \_\_\_\_\_

REPLACEMENT WIRE SIZE AND TYPE: \_\_\_\_\_

WARNING: WIRING MUST BE PERMANENTLY GROUNDING AND CONFORM TO I.E.C., N.E.C., C.E.C., AND ALL APPLICABLE NATIONAL AND LOCAL CODES AS APPLICABLE.

Figure 26 continued: MPS 012D, 208-230/460 Volt (Constant Volume Cooling Only — Electromechanical Controls)

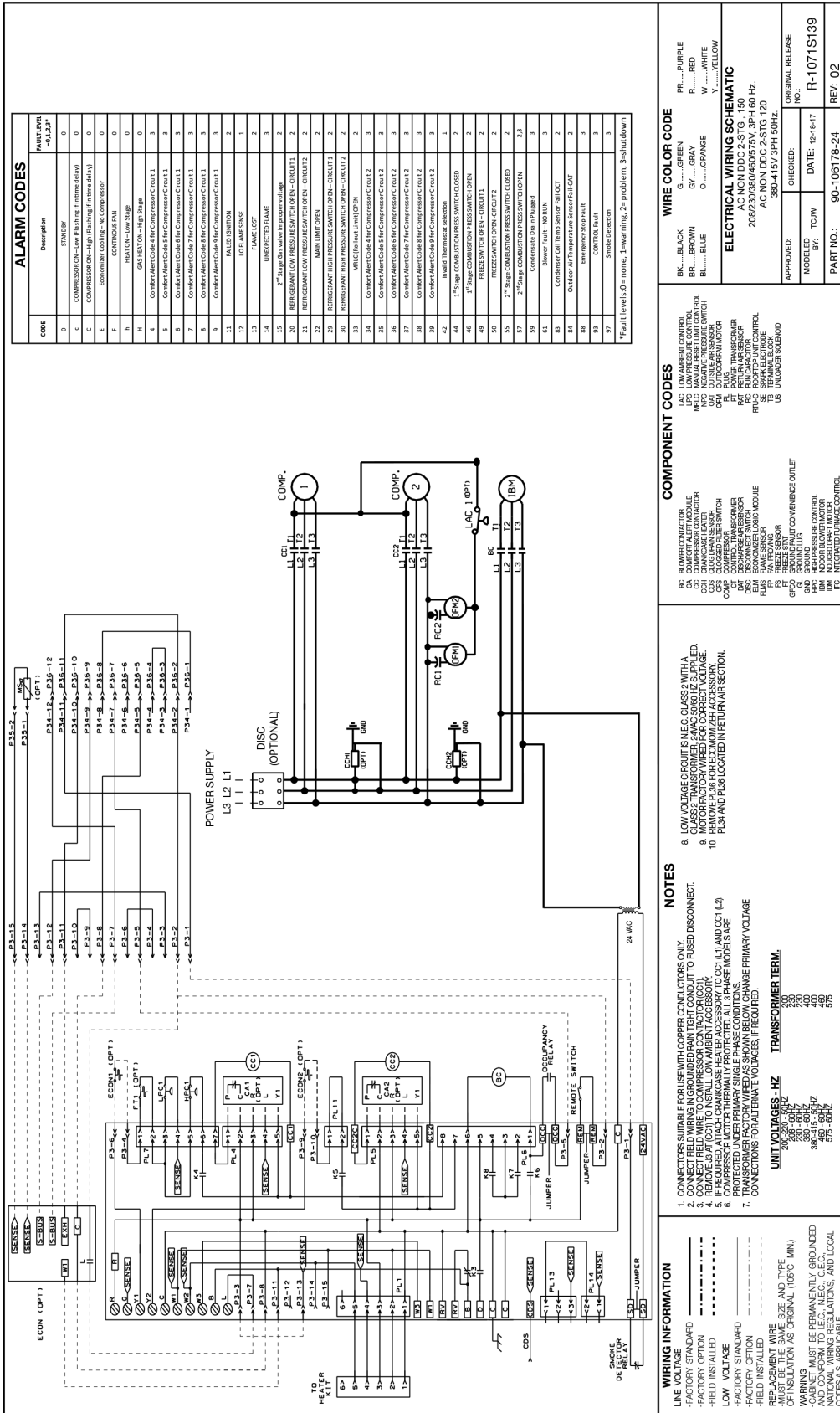



Figure 27 continued: MPS 007-010D, 208-230/460 Volt (Two-Speed SAF Cooling Only — Electromechanical Controls)

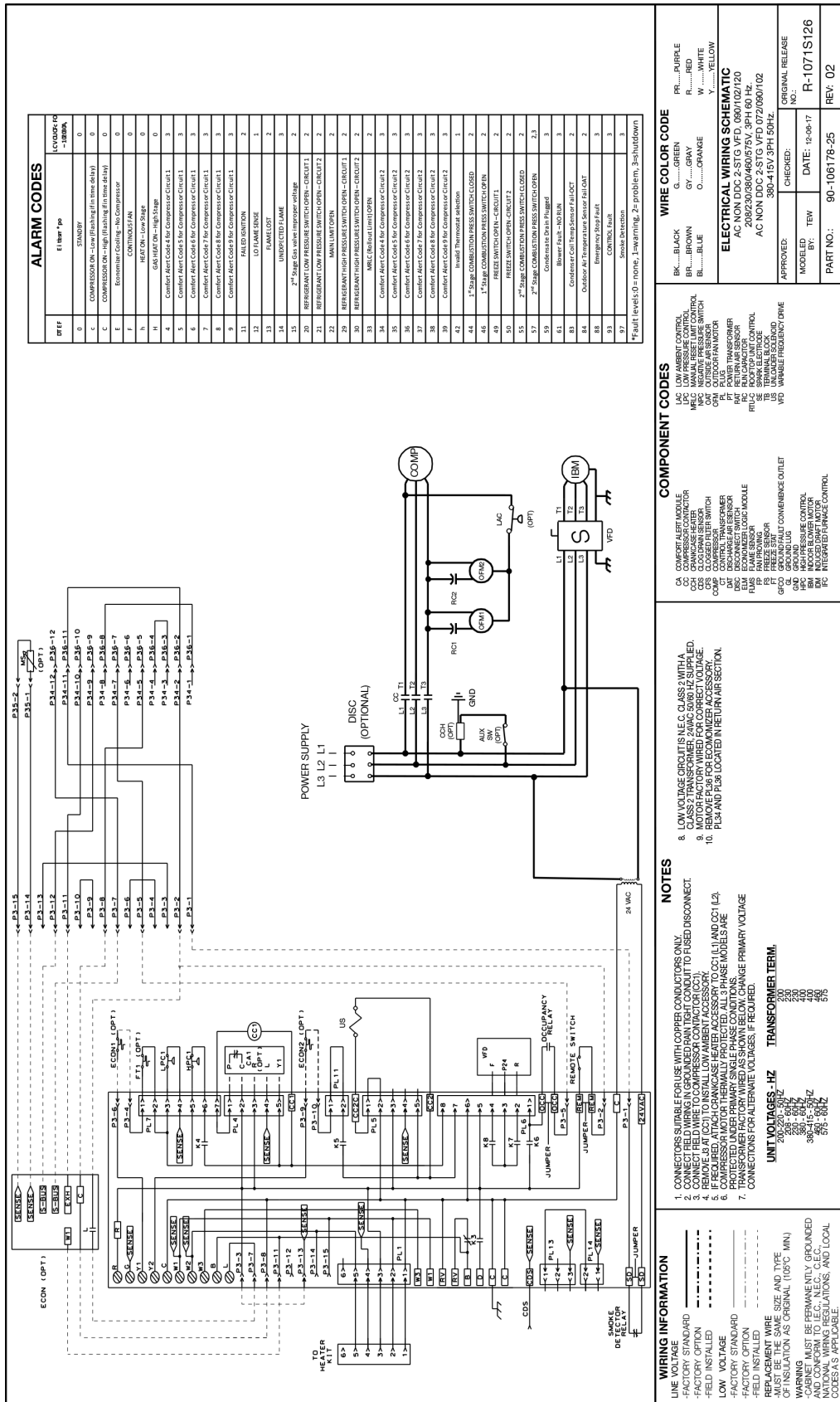
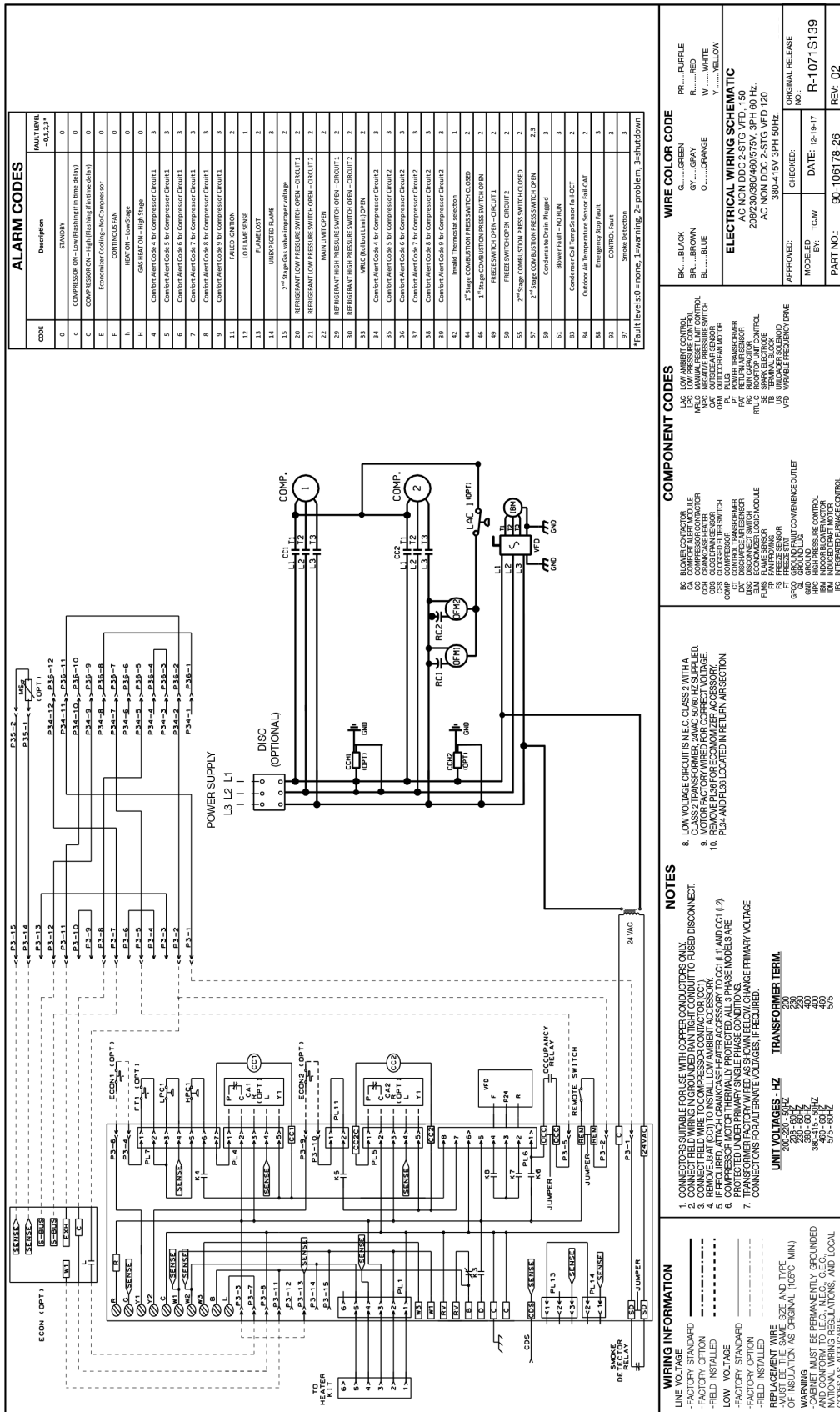



Figure 28 continued: MPS 012D, 208-230/460 Volt (Two-Speed SAF Cooling Only — Electromechanical Controls)



**ALARMS CODES**

FAULT LEVEL (0-3-shutdown)

**COMPONENT CODES**

BC BLOWER CONTACTOR  
 CA COMPACT ALERT MODULE  
 CH CRANKCASE HEATER  
 CO COIL  
 CS CRANKCASE HEATER ACCESSORY TO CCT(L) AND CCT(L2)  
 CS2 CRANKCASE HEATER ACCESSORY TO CCT(L) AND CCT(L2)  
 CS3 CRANKCASE HEATER ACCESSORY TO CCT(L) AND CCT(L2)  
 CS4 CRANKCASE HEATER ACCESSORY TO CCT(L) AND CCT(L2)  
 CS5 CRANKCASE HEATER ACCESSORY TO CCT(L) AND CCT(L2)  
 CS6 CRANKCASE HEATER ACCESSORY TO CCT(L) AND CCT(L2)  
 CS7 CRANKCASE HEATER ACCESSORY TO CCT(L) AND CCT(L2)  
 CS8 CRANKCASE HEATER ACCESSORY TO CCT(L) AND CCT(L2)  
 CS9 CRANKCASE HEATER ACCESSORY TO CCT(L) AND CCT(L2)  
 CS10 CRANKCASE HEATER ACCESSORY TO CCT(L) AND CCT(L2)  
 CS11 CRANKCASE HEATER ACCESSORY TO CCT(L) AND CCT(L2)  
 CS12 CRANKCASE HEATER ACCESSORY TO CCT(L) AND CCT(L2)  
 CS13 CRANKCASE HEATER ACCESSORY TO CCT(L) AND CCT(L2)  
 CS14 CRANKCASE HEATER ACCESSORY TO CCT(L) AND CCT(L2)  
 CS15 CRANKCASE HEATER ACCESSORY TO CCT(L) AND CCT(L2)  
 CS16 CRANKCASE HEATER ACCESSORY TO CCT(L) AND CCT(L2)  
 CS17 CRANKCASE HEATER ACCESSORY TO CCT(L) AND CCT(L2)  
 CS18 CRANKCASE HEATER ACCESSORY TO CCT(L) AND CCT(L2)  
 CS19 CRANKCASE HEATER ACCESSORY TO CCT(L) AND CCT(L2)  
 CS20 CRANKCASE HEATER ACCESSORY TO CCT(L) AND CCT(L2)  
 CS21 CRANKCASE HEATER ACCESSORY TO CCT(L) AND CCT(L2)  
 CS22 CRANKCASE HEATER ACCESSORY TO CCT(L) AND CCT(L2)  
 CS23 CRANKCASE HEATER ACCESSORY TO CCT(L) AND CCT(L2)  
 CS24 CRANKCASE HEATER ACCESSORY TO CCT(L) AND CCT(L2)  
 CS25 CRANKCASE HEATER ACCESSORY TO CCT(L) AND CCT(L2)  
 CS26 CRANKCASE HEATER ACCESSORY TO CCT(L) AND CCT(L2)  
 CS27 CRANKCASE HEATER ACCESSORY TO CCT(L) AND CCT(L2)  
 CS28 CRANKCASE HEATER ACCESSORY TO CCT(L) AND CCT(L2)  
 CS29 CRANKCASE HEATER ACCESSORY TO CCT(L) AND CCT(L2)  
 CS30 CRANKCASE HEATER ACCESSORY TO CCT(L) AND CCT(L2)  
 CS31 CRANKCASE HEATER ACCESSORY TO CCT(L) AND CCT(L2)  
 CS32 CRANKCASE HEATER ACCESSORY TO CCT(L) AND CCT(L2)  
 CS33 CRANKCASE HEATER ACCESSORY TO CCT(L) AND CCT(L2)  
 CS34 CRANKCASE HEATER ACCESSORY TO CCT(L) AND CCT(L2)  
 CS35 CRANKCASE HEATER ACCESSORY TO CCT(L) AND CCT(L2)  
 CS36 CRANKCASE HEATER ACCESSORY TO CCT(L) AND CCT(L2)  
 CS37 CRANKCASE HEATER ACCESSORY TO CCT(L) AND CCT(L2)  
 CS38 CRANKCASE HEATER ACCESSORY TO CCT(L) AND CCT(L2)  
 CS39 CRANKCASE HEATER ACCESSORY TO CCT(L) AND CCT(L2)  
 CS40 CRANKCASE HEATER ACCESSORY TO CCT(L) AND CCT(L2)  
 CS41 CRANKCASE HEATER ACCESSORY TO CCT(L) AND CCT(L2)  
 CS42 CRANKCASE HEATER ACCESSORY TO CCT(L) AND CCT(L2)  
 CS43 CRANKCASE HEATER ACCESSORY TO CCT(L) AND CCT(L2)  
 CS44 CRANKCASE HEATER ACCESSORY TO CCT(L) AND CCT(L2)  
 CS45 CRANKCASE HEATER ACCESSORY TO CCT(L) AND CCT(L2)  
 CS46 CRANKCASE HEATER ACCESSORY TO CCT(L) AND CCT(L2)  
 CS47 CRANKCASE HEATER ACCESSORY TO CCT(L) AND CCT(L2)  
 CS48 CRANKCASE HEATER ACCESSORY TO CCT(L) AND CCT(L2)  
 CS49 CRANKCASE HEATER ACCESSORY TO CCT(L) AND CCT(L2)  
 CS50 CRANKCASE HEATER ACCESSORY TO CCT(L) AND CCT(L2)  
 CS51 CRANKCASE HEATER ACCESSORY TO CCT(L) AND CCT(L2)  
 CS52 CRANKCASE HEATER ACCESSORY TO CCT(L) AND CCT(L2)  
 CS53 CRANKCASE HEATER ACCESSORY TO CCT(L) AND CCT(L2)  
 CS54 CRANKCASE HEATER ACCESSORY TO CCT(L) AND CCT(L2)  
 CS55 CRANKCASE HEATER ACCESSORY TO CCT(L) AND CCT(L2)  
 CS56 CRANKCASE HEATER ACCESSORY TO CCT(L) AND CCT(L2)  
 CS57 CRANKCASE HEATER ACCESSORY TO CCT(L) AND CCT(L2)  
 CS58 CRANKCASE HEATER ACCESSORY TO CCT(L) AND CCT(L2)  
 CS59 CRANKCASE HEATER ACCESSORY TO CCT(L) AND CCT(L2)  
 CS60 CRANKCASE HEATER ACCESSORY TO CCT(L) AND CCT(L2)  
 CS61 CRANKCASE HEATER ACCESSORY TO CCT(L) AND CCT(L2)  
 CS62 CRANKCASE HEATER ACCESSORY TO CCT(L) AND CCT(L2)  
 CS63 CRANKCASE HEATER ACCESSORY TO CCT(L) AND CCT(L2)  
 CS64 CRANKCASE HEATER ACCESSORY TO CCT(L) AND CCT(L2)  
 CS65 CRANKCASE HEATER ACCESSORY TO CCT(L) AND CCT(L2)  
 CS66 CRANKCASE HEATER ACCESSORY TO CCT(L) AND CCT(L2)  
 CS67 CRANKCASE HEATER ACCESSORY TO CCT(L) AND CCT(L2)  
 CS68 CRANKCASE HEATER ACCESSORY TO CCT(L) AND CCT(L2)  
 CS69 CRANKCASE HEATER ACCESSORY TO CCT(L) AND CCT(L2)  
 CS70 CRANKCASE HEATER ACCESSORY TO CCT(L) AND CCT(L2)  
 CS71 CRANKCASE HEATER ACCESSORY TO CCT(L) AND CCT(L2)  
 CS72 CRANKCASE HEATER ACCESSORY TO CCT(L) AND CCT(L2)  
 CS73 CRANKCASE HEATER ACCESSORY TO CCT(L) AND CCT(L2)  
 CS74 CRANKCASE HEATER ACCESSORY TO CCT(L) AND CCT(L2)  
 CS75 CRANKCASE HEATER ACCESSORY TO CCT(L) AND CCT(L2)  
 CS76 CRANKCASE HEATER ACCESSORY TO CCT(L) AND CCT(L2)  
 CS77 CRANKCASE HEATER ACCESSORY TO CCT(L) AND CCT(L2)  
 CS78 CRANKCASE HEATER ACCESSORY TO CCT(L) AND CCT(L2)  
 CS79 CRANKCASE HEATER ACCESSORY TO CCT(L) AND CCT(L2)  
 CS80 CRANKCASE HEATER ACCESSORY TO CCT(L) AND CCT(L2)  
 CS81 CRANKCASE HEATER ACCESSORY TO CCT(L) AND CCT(L2)  
 CS82 CRANKCASE HEATER ACCESSORY TO CCT(L) AND CCT(L2)  
 CS83 CRANKCASE HEATER ACCESSORY TO CCT(L) AND CCT(L2)  
 CS84 CRANKCASE HEATER ACCESSORY TO CCT(L) AND CCT(L2)  
 CS85 CRANKCASE HEATER ACCESSORY TO CCT(L) AND CCT(L2)  
 CS86 CRANKCASE HEATER ACCESSORY TO CCT(L) AND CCT(L2)  
 CS87 CRANKCASE HEATER ACCESSORY TO CCT(L) AND CCT(L2)  
 CS88 CRANKCASE HEATER ACCESSORY TO CCT(L) AND CCT(L2)  
 CS89 CRANKCASE HEATER ACCESSORY TO CCT(L) AND CCT(L2)  
 CS90 CRANKCASE HEATER ACCESSORY TO CCT(L) AND CCT(L2)  
 CS91 CRANKCASE HEATER ACCESSORY TO CCT(L) AND CCT(L2)  
 CS92 CRANKCASE HEATER ACCESSORY TO CCT(L) AND CCT(L2)  
 CS93 CRANKCASE HEATER ACCESSORY TO CCT(L) AND CCT(L2)  
 CS94 CRANKCASE HEATER ACCESSORY TO CCT(L) AND CCT(L2)  
 CS95 CRANKCASE HEATER ACCESSORY TO CCT(L) AND CCT(L2)  
 CS96 CRANKCASE HEATER ACCESSORY TO CCT(L) AND CCT(L2)  
 CS97 CRANKCASE HEATER ACCESSORY TO CCT(L) AND CCT(L2)  
 CS98 CRANKCASE HEATER ACCESSORY TO CCT(L) AND CCT(L2)  
 CS99 CRANKCASE HEATER ACCESSORY TO CCT(L) AND CCT(L2)  
 CS100 CRANKCASE HEATER ACCESSORY TO CCT(L) AND CCT(L2)

**WIRE COLOR CODE**

BK.....BLACK  
 BR.....BROWN  
 BL.....BLUE  
 G.....GREEN  
 GR.....GRAY  
 O.....ORANGE  
 PR.....PURPLE  
 R.....RED  
 W.....WHITE  
 Y.....YELLOW

**ELECTRICAL WIRING SCHEMATIC**

AC NON DDC 2-STG VFD 150  
 208-230/460V 3PH 50HZ  
 AC NON DDC 2-STG VFD 120  
 208-230/460V 3PH 50HZ

APPROVED: \_\_\_\_\_  
 MODEL NO. \_\_\_\_\_  
 DATE: 12-19-17  
 ORIGINAL RELEASE NO.: R-1071S139

PART NO.: 90-106178-26  
 REV: 02

**NOTES**

1. CONNECTORS SUITABLE FOR USE WITH COPPER CONDUCTORS ONLY.  
 2. CONNECT FIELD WIRING IN GROUNDING RAIL TO FIELD DISCONNECT.  
 3. REMOVE (L3) CCI TO INSTALL LOW AMBIENT ACCESSORY.  
 4. REMOVE (L3) CCI TO INSTALL LOW AMBIENT ACCESSORY.  
 5. IF REQUIRED, ATTACH CRANKCASE HEATER ACCESSORY TO CCT(L) AND CCT(L2).  
 6. PROTECTED UNDER PRIMARY SINGLE PHASE CONDITIONS.  
 7. TRANSFORMER FACTORY WIRE AS SHOWN BELOW. CHANGE PRIMARY VOLTAGE CONNECTIONS FOR ALTERNATE VOLTAGES, IF REQUIRED.

**UNIT VOLTAGES - HZ**

TRANSFORMER TERM.	200	230	250	380	400	460	575
208-230-50/2							
230-50/2							
250-50/2							
380-415-50/2							
400-50/2							
460-50/2							
575-50/2							

**WIRING INFORMATION**

LINE VOLTAGE  
 -FACTORY STANDARD  
 -FIELD INSTALLED  
 -FIELD INSTALLED  
 -FACTORY STANDARD  
 -FACTORY OPTION  
 -FIELD INSTALLED

REPLACEMENT WIRE MUST BE THE SAME SIZE AND TYPE AS ORIGINAL (105°C MIN).  
 -CABINET MUST BE PERMANENTLY GROUNDED AND CONNECTED TO C.C. N.E.C. GEC AND CANADIAN REGULATIONS, AND LOCAL CODES AS APPLICABLE.







Figure 30 continued: MPS 012D, 208-230/460 Volt (Constant Volume Cooling Only — DDC Controls)

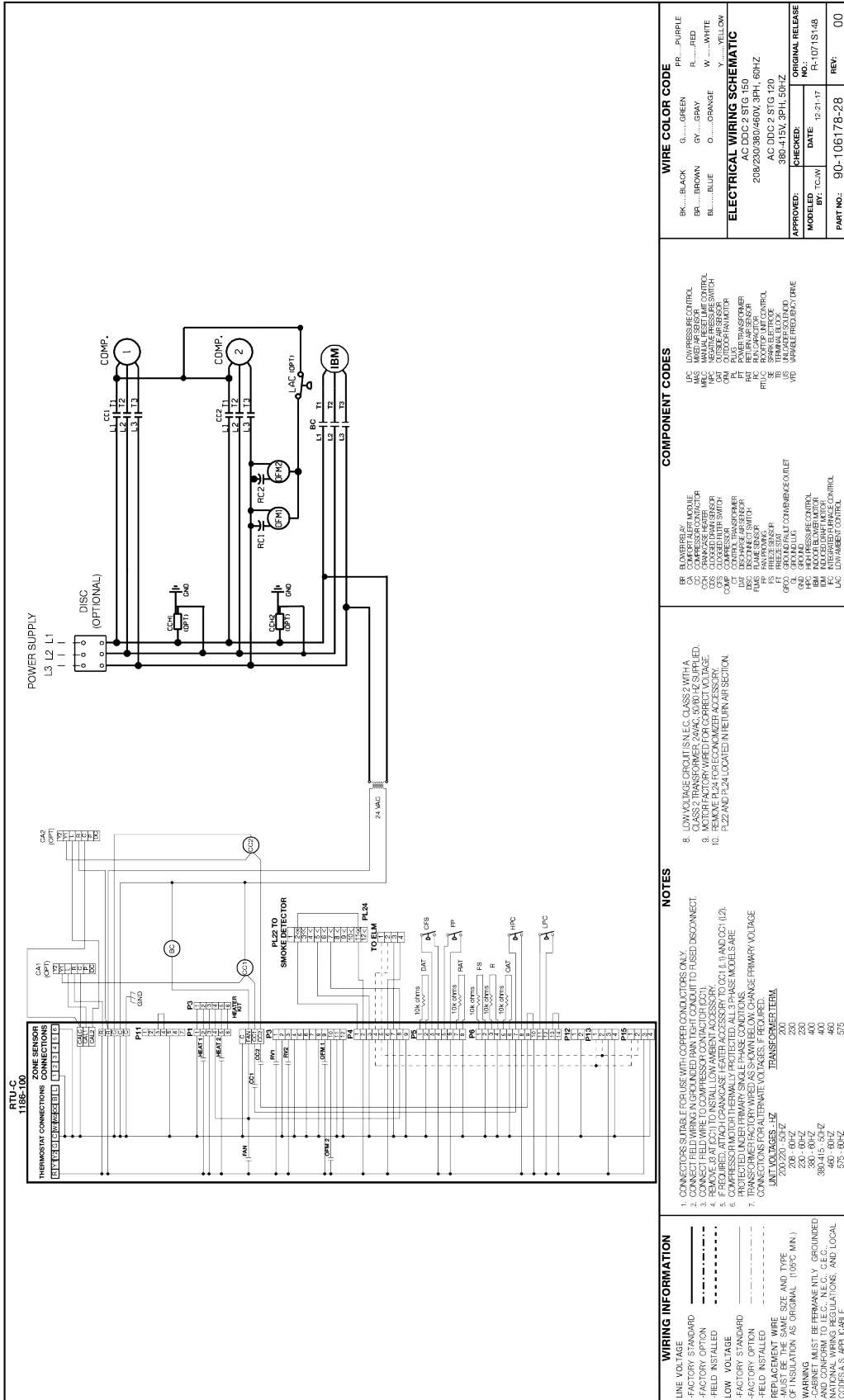

**WIRE COLOR CODE**

BK...BLACK	G.....GREEN	PP.....PURPLE
BR...BROWN	GY.....GRAY	R.....RED
BL...BLUE	O.....ORANGE	W.....WHITE
		Y.....YELLOW

**ELECTRICAL WIRING SCHEMATIC**  
AC DDC 2 STG 150  
208/230/360/460V, 3PH, 60HZ  
AC DDC 2 STG 120  
380-415V, 3PH, 50HZ

APPROVED:	CHECKED:	DATE:	ORIGINAL RELEASE
BT, TC, WJ		12-21-17	R-10715148
PART NO.:	REV:		
90-106178-28	00		

**COMPONENT CODES**

BR	BLOWER RELAY	IS	INDUSTRY FIELD CONTROL
CC	COMPRESSOR CONTACTOR	MAC	MANUAL RESET SENSOR
CH	CHAMBER HEATER	MFC	MANUAL FRESH AIR CONTROL
CHS	CHAMBER HEATER SWITCH	OC	OVERCURRENT PROTECT
CO	COIL	OUT	OUTDOOR AIR SENSOR
CO2	CO2 SENSOR	PL	PLUMBING SENSOR
CO2T	CO2 TRANSFORMER	PLA	PLUMBING AIR SENSOR
CON	CONTROL	PR	PREHEATER
CONTR	CONTROL TRANSFORMER	PR1	PREHEATER AIR SENSOR
CS	CASE	PTC	PTC MOTOR CONTROL
DIS	DISCONNECT SWITCH	RE	REHEATER
F	FAN	RETC	REHEATER CONTROL
FBS	FAN SENSOR	TE	TEMPERATURE
FS	FRESH AIR SENSOR	TR	TRANSFORMER
FS2	FRESH AIR SENSOR 2	US	UNIT INTERLOCK DRY
FS3	FRESH AIR SENSOR 3	VB	VARIABLE FREQUENCY DRIVE
GF	GRAND PULL		
GF2	GRAND PULL 2		
GF3	GRAND PULL 3		
GR	GRAND PULL		
IBM	IBM		
IND	INDUSTRY FIELD CONTROL		
LAC	LIVABLE CONTROL		

- NOTES**
- CONNECTORS SUITABLE FOR USE WITH COPPER CONDUCTORS ONLY.
  - CONNECT FIELD WIRING IN GROUNDING RAIN TIGHT CONDUIT TO PREVENT DISCONNECT.
  - SMOKE DETECTOR WIRING TO BE INSTALLED IN ACCORDANCE WITH MANUFACTURER'S INSTRUCTIONS.
  - SMOKE DETECTOR ATTACH CRANKCASE HEATER ACCESSORY TO OCC 1, 1 AND OCC 1 (U2).
  - COMPRESSOR MOTOR THERMALLY PROTECTED. ALL 3 PHASE MODELS ARE THERMALLY PROTECTED.
  - TRANSFORMER FACTORY WIRING AS SHOWN USE ONLY ON CHANGE PRIMARY VOLTAGE.
  - CONNECTIONS FOR ALTERNATE VOLTAGES, IF REQUIRED, TRANSFORMER TERM.
- |                    |     |
|--------------------|-----|
| UNIT VOLTAGES - HZ | 200 |
| 208-230-60HZ       | 230 |
| 230-60HZ           | 400 |
| 380-60HZ           | 460 |
| 460-60HZ           | 575 |
| 575-60HZ           |     |

**WIRING INFORMATION**

LINE VOLTAGE	208-230/460V
FACTORY STANDARD	FIELD INSTALLED
FIELD INSTALLED	FACTORY STANDARD
WIRE GAUGE	WIRE GAUGE
FACTORY STANDARD	FACTORY OPTION
FACTORY OPTION	FACTORY STANDARD
REPLACEMENT WIRE	REPLACEMENT WIRE
MUST BE THE SAME SIZE AND TYPE	MUST BE THE SAME SIZE AND TYPE
AS ORIGINAL	AS ORIGINAL
WARNING: WIRING MUST BE PERMANENTLY GROUNDED AND CONFORM TO I.E.C. N.E.C. C.E.C. REGULATIONS, AND LOCAL CODES AS APPLICABLE.	







Figure 32 continued: MPS 012D, 208-230/460 Volt (Two-Speed SAF Cooling Only — DDC Controls)

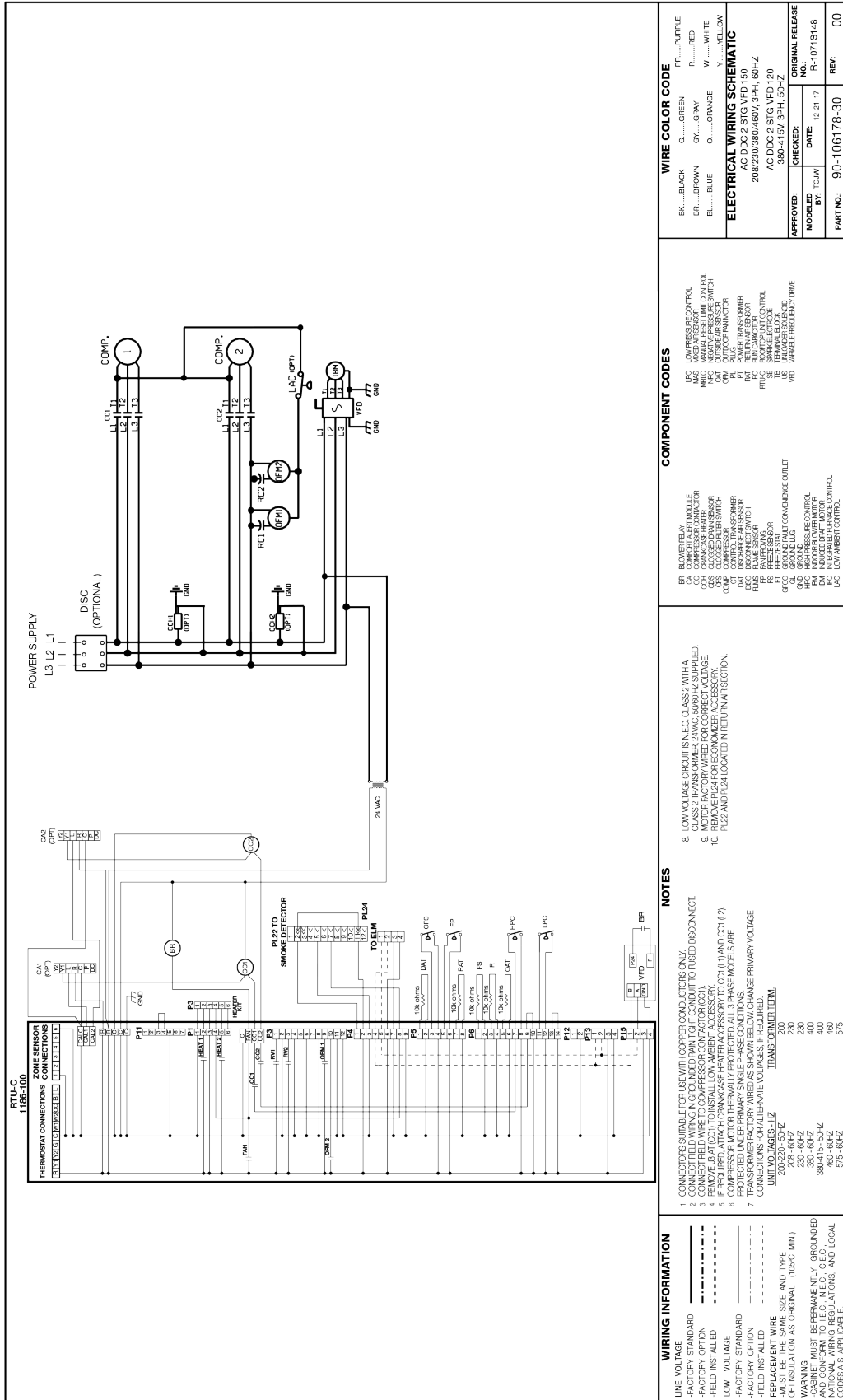

WIRE COLOR CODE	
BK.....BLACK	G.....GREEN
BR.....BROWN	GY.....GRAY
BL.....BLUE	O.....ORANGE
PK.....PURPLE	R.....RED
	W.....WHITE
	Y.....YELLOW

ELECTRICAL WIRING SCHEMATIC	
APPROVED:	CHECKED:
MODELED BY: TCJM	DATE: 12-21-17
PART NO.: 90-106178-30	REV: 00

COMPONENT CODES	
BA	BLU/RETRY
BC	COMPRESSOR MODULE
CC	COMPRESSOR CONTACTOR
CS	CLOSED/OPEN SENSOR
CP	COMPRESSOR
DA	DIFFERENTIAL SWITCH
DC	DISCONNECT SWITCH
DF	DIFFERENTIAL SWITCH
DR	DRIP PAN
FL	FREELINE
GL	GROUNDING
GR	GRANITE
IR	IR SENSOR
MC	MODULATED COMPRESSOR
MD	MODULATED COMPRESSOR
PC	INTEGRATED FURNACE CONTROL
UC	LOW AMBIENT CONTROL

- NOTES**
- CONNECTORS SUITABLE FOR USE WITH COPPER CONDUCTORS ONLY.
  - CONNECT FIELD WIRE TO COMPRESSOR CONTACTOR.
  - REMOVE J3 AT (CCT) TO INSTALL LOW AMBIENT ACCESSORY.
  - IF REQUIRED, ATTACH CRANKCASE HEATED ACCESSORY TO CCT (L1) AND CCT (L2).
  - PROTECTED UNDER PRIMARY SINGLE PHASE CONDITIONS.
  - TRANSFORMER FACTORY WIRE AS SHOWN BELOW CHANGE PRIMARY VOLTAGE CONNECTIONS FOR ALTERNATE VOLTAGES. IF REQUIRED.
  - TRANSFORMER TERMINALS:
    - 208-230-50HZ
    - 230-460HZ
    - 230-460HZ
    - 460-920HZ
    - 380-415-50HZ
    - 480-60HZ
    - 575-69HZ

WIRING INFORMATION	
LINE VOLTAGE	FACTORY STANDARD
FACTORY OPTION	FIELD INSTALLED
LOW VOLTAGE	FACTORY STANDARD
FACTORY OPTION	FIELD INSTALLED
REPLACEMENT WIRE	FACTORY STANDARD
FACTORY OPTION	FIELD INSTALLED
WARNING	CABINET MUST BE PERMANENTLY GROUNDED
	NATIONAL WIRING REGULATIONS AND LOCAL CODES AS APPLICABLE.

Figure 33: MPS 007-010D, 208-230/460 Volt (Two-Speed SAF with HGRH — DDC Controls)

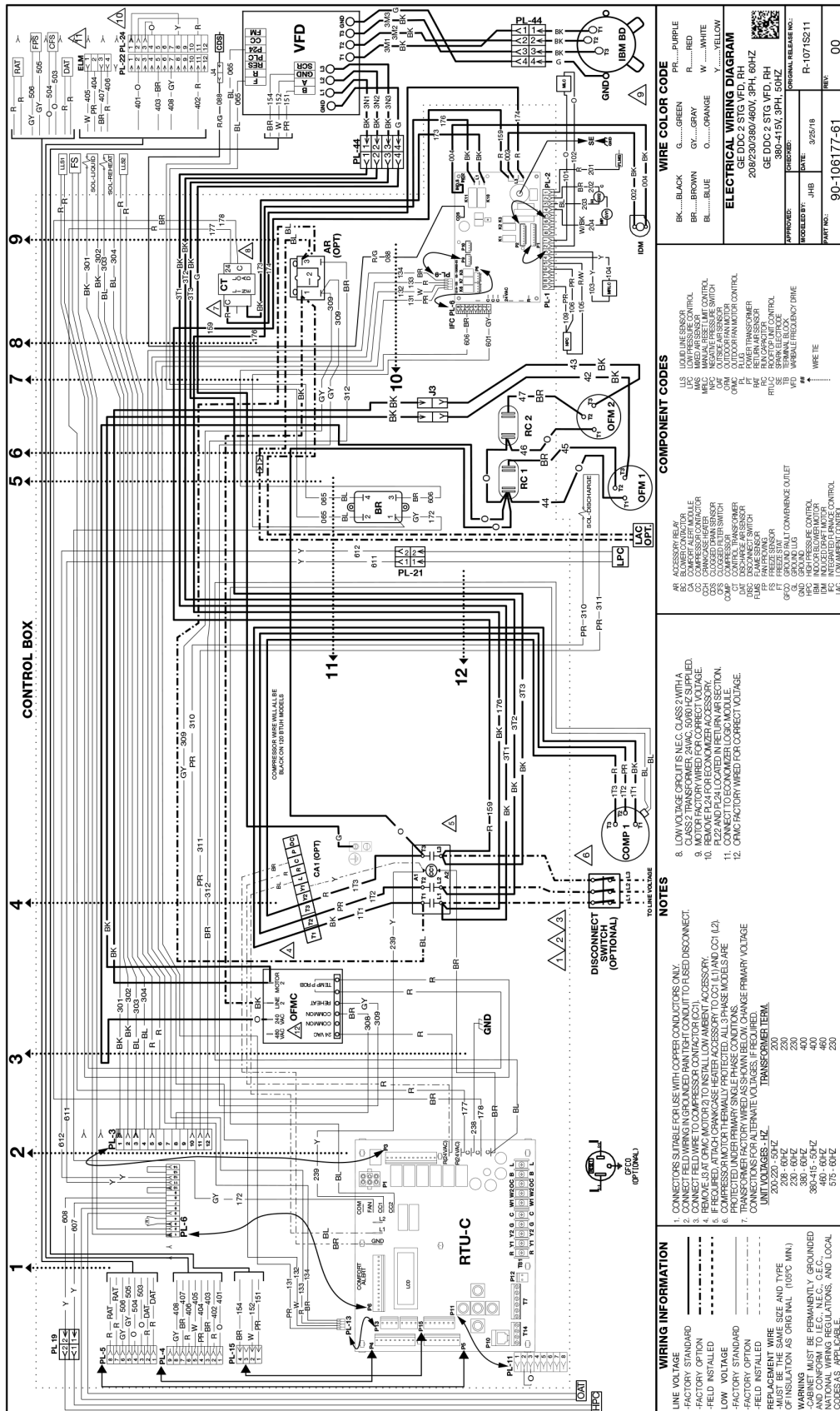

**WIRING INFORMATION**

- LINE VOLTAGE
- FACTORY STANDARD
- FIELD INSTALLED
- LOW VOLTAGE
- FACTORY STANDARD
- FACTORY OPTION
- FIELD INSTALLED
- REPLACEMENT WIRE SIZE AND TYPE
- OF INSULATION AS ORIG INAL (105°C MIN)

**NOTES**

- CONNECTORS SUITABLE FOR USE WITH COPPER CONDUCTORS ONLY.
- CLASS 2 TRANSFORMER (CLASS 2) TO BE USED FOR DISCONNECT.
- CONNECT FIELD WIRE TO COMPRESSOR CONTACTOR (C01) TO BE USED FOR DISCONNECT.
- REMOVE 0.8 AT CFC MOTOR 2 TO INSTALL LOW AMBIENT ACCESSORY.
- REMOVE 0.8 AT CFC MOTOR 1 TO INSTALL LOW AMBIENT ACCESSORY.
- REMOVE 0.8 AT CFC MOTOR 1 TO INSTALL LOW AMBIENT ACCESSORY.
- COMPRESSOR MOTOR THERMALLY PROTECTED ALL PHASES (R, Y, B).
- PROTECTED UNDER PRIMARY SINGLE PHASE CONDITIONS.
- TRANSFORMER FACTORY WIRE AS SHOWN BELOW. CHANGE PRIMARY VOLTAGE TO MATCH FIELD WIRE VOLTAGE.
- UNIT VOLTAGES - HZ

200-230-50/4Z	200
230-230-50/4Z	230
230-460-50/4Z	400
380-415-50/4Z	400
460-604Z	460
515-604Z	230

**COMPONENT CODES**

- LS LOAD LINE SENSOR
- MS MOUNTING SENSOR
- MAL MANUAL RESET LIMIT CONTROL
- MSL MOUNTING SENSOR
- OS OUTSIDE AIR SENSOR
- OSI OUTSIDE AIR SENSOR
- OMK OUTDOOR FAN MOTOR CONTROL
- PF POWER TRANSFORMER
- PLZ PLZ
- PLZ2 PLZ2
- PLZ4 PLZ4
- PLZ42 PLZ42
- PLZ44 PLZ44
- PLZ46 PLZ46
- PLZ48 PLZ48
- PLZ50 PLZ50
- PLZ52 PLZ52
- PLZ54 PLZ54
- PLZ56 PLZ56
- PLZ58 PLZ58
- PLZ60 PLZ60
- PLZ62 PLZ62
- PLZ64 PLZ64
- PLZ66 PLZ66
- PLZ68 PLZ68
- PLZ70 PLZ70
- PLZ72 PLZ72
- PLZ74 PLZ74
- PLZ76 PLZ76
- PLZ78 PLZ78
- PLZ80 PLZ80
- PLZ82 PLZ82
- PLZ84 PLZ84
- PLZ86 PLZ86
- PLZ88 PLZ88
- PLZ90 PLZ90
- PLZ92 PLZ92
- PLZ94 PLZ94
- PLZ96 PLZ96
- PLZ98 PLZ98
- PLZ100 PLZ100

**WIRE COLOR CODE**

- BK...BLACK
- BR...BROWN
- BL...BLUE
- GY...GRAY
- GR...GREEN
- OR...ORANGE
- PR...PURPLE
- RD...RED
- WH...WHITE
- Y...YELLOW

**ELECTRICAL WIRING DIAGRAM**

GE DDC 2 STG VFD, HGRH, BMBD  
 GE DDC 2 STG VFD, HGRH, BMBD  
 GE DDC 2 STG VFD, HGRH, BMBD

APPROVED BY: JHB DATE: 3/25/18  
 R-1075211  
 PART NO.: 90-106177-61  
 REV: 00







# Unit Capacity and Physical Data

Table 14: MPS 007D – 012D

Model	MPS			
	007D	008D	010D	012D
<b>Cooling Performance<sup>1</sup></b>				
Gross cooling BTU [kW]	88,000 [25.78]	99,000 [29.01]	118,000 [34.57]	148,000 [43.36]
EER/SEER <sup>2</sup>	11.2/NA	11.2/NA	11.2/NA	11/NA
Nominal airflow/ARI airflow (cfm) [L/s]	3000/3175 [1416/1498]	3400/3225 [1604/1522]	4000/3480 [1888/1642]	5000/3750 [2360/1770]
Net cooling BTU [kW]	85,000 [24.9]	96,000 [28.13]	114,000 [33.4]	142,000 [41.61]
Net sensible BTU [kW]	62,700 [18.37]	68,300 [20.01]	79,600 [23.32]	98,600 [28.89]
Net latent BTU [kW]	22,300 [6.53]	27,700 [8.12]	34,400 [10.08]	43,400 [12.72]
Net system power kW	7.35	7.35	9.83	13.69
<b>Compressor(s)</b>				
Type/number	Scroll/1	Scroll/1	Scroll/1	Scroll/2
<b>Gas Heating Performance<sup>3</sup></b>				
AFUE %	80	80	80	80
Steady stage efficiency %	81	81	81	81
No. stages	2	2	2	2
Gas connection size	3/4"	3/4"	3/4"	3/4"
Heating input (BtuH)	105,000/205,000	105,000/225,000	150,000/225,000	105,000/225,000
Heating output (BtuH)	85,050/166,050	85,050/182,250	85,050/182,250	85,050/182,250
Temperature rise °F	20 – 50	15 – 65	10 – 45	5 – 40
<b>Sound<sup>4</sup></b>				
Outdoor rating (dB)	88	88	88	88
<b>Outdoor Coil</b>				
Fin type	Louvered	Louvered	Louvered	Louvered
Tube type	MicroChannel	MicroChannel	MicroChannel	MicroChannel
MicroChannel Depth (in.) [mm]	0.71 [18]	0.81 [20.6]	1 [25.4]	1 [25.4]
Face area (sq. ft) [sq. m]	25.4 [2.36]	25.6 [2.38]	25.6 [2.38]	31.5 [2.93]
Rows (fpi) [fpcm]	1/23 [19.05]	1/23 [9]	1/23 [9]	1/23 [9]
<b>Indoor Coil</b>				
Fin type	Louvered	Louvered	Louvered	Louvered
Tube type	MicroChannel	MicroChannel	MicroChannel	MicroChannel
MicroChannel Depth (in.) [mm]	1 [25.4]	1.26 [32]	1.26 [32]	1 [25.4]
Face area (sq. ft) [sq. m]	11 [1.02]	10.9 [1.01]	10.9 [1.01]	13.8 [1.28]
Rows (fpi) [fpcm]	1/20 [8]	1/20 [8]	1/20 [8]	2/18 [7]
Refrigerant control	TX valves	TX valves	TX valves	TX valves
Drain connection (in.) [mm]	1/0.75 [19.05]	1/0.75 [19.05]	1/0.75 [19.05]	1/0.75 [19.05]
<b>Condenser Fan</b>				
Type	Propeller	Propeller	Propeller	Propeller
No. used/diameter (in.) [mm]	2/24 [609.6]	2/24 [609.6]	2/24 [609.6]	2/24 [609.6]
Drive type/No. of speeds	Direct/1	Direct/1	Direct/1	Direct/1
CFM [L/s]	8000 [3775]	8000 [3775]	8500 [4011]	9000 [4247]
Motor hp	2 at 1/5 HP	2 at 1/5 HP	2 at 1/3 HP	2 at 3/4 HP
Motor rpm	820	820	1075	1100
<b>Indoor Fan</b>				
Type	FC Centrifugal	FC Centrifugal	FC Centrifugal	FC Centrifugal
No. used/diameter (in.) [mm]	1/15×15 [381×381]	1/15×15 [381×381]	1/15×15 [381×381]	1/15×15 [381×381]
No. motors	1	1	1	1
Motor hp	2 – 3	2 – 3	2 – 3	3 - 5
Motor rpm	1725	1725	1725	1725
<b>Filter</b>				
Fin type	Disposable	Disposable	Disposable	Disposable
Furnished	Yes	Yes	Yes	Yes
No. size (in.) [mm]	(4) 2×20×20 [51×508×508]	(6) 2×20×20 [51×508×508]	(4) 2×20×20 [51×508×508]	(4) 2×20×25 [51×508×635]
<b>Refrigerant</b>				
Charge oz. [g]	100 [2835]	122 [3458]	136 [3856]	186 [5273]
Net weight lbs. [kg]	736 [334]	762 [346]	791 [359]	993 [450]
Shipping weight lbs. [kg]	775 [352]	801 [363]	830 [376]	1032 [468]

**NOTES:**  
 1. Cooling Performance is rated at 95° F ambient, 80° F entering dry bulb, 67° F entering wet bulb. Gross capacity does not include the effect of fan motor heat. AHRI capacity is net and includes the effect of fan motor heat. Units are suitable for operation to ±20% of nominal CFM. Units are certified in accordance with the Unitary Air Conditioner Equipment certification program, which is based on AHRI Standard 210/240 or 360.  
 2. EER and/or SEER are rated at AHRI conditions and in accordance with DOE test procedures.  
 3. Integrated Energy Efficiency Ratio (IEER) is rated in accordance with AHRI Standard 340/360.  
 4. Outdoor Sound Rating shown is tested in accordance with AHRI Standard 270.

# Electrical Data

## Compressor and Condenser Motor

Table 15: Compressor and Condenser Motor Data – 208/230 Volt

Data	MPS 007D	MPS 008D	MPS 010D	MPS 012D
<b>Compressor Motor</b>				
Number.	1	1	1	2
Phase	3			
RPM	3450			
HP, Compressor 1	7	7.5	10	6
Amps (RLA), Comp. 1	25.3	28.8	32.6	25
Amps (LRA), Comp. 1	184.0	191	240	164
HP, Compressor 2	N/A	N/A	N/A	6
Amps (RLA), Comp. 2	N/A	N/A	N/A	25
Amps (LRA), Comp. 2	N/A	N/A	N/A	164
<b>Condenser Motor</b>				
Number	2			
Phase	1			
HP	1/5	1/5	1/3	3/4
Amps (FLA, each)	1.2	1.2	2.4	4.2
Amps (LRA, each)	2.3	2.3	4.7	10.1

NOTE: \*Unit operating voltage range is 187 – 253

Table 16: Compressor and Condenser Motor Data – 460 Volt

Data	MPS 007D	MPS 008D	MPS 010D	MPS 012D
<b>Compressor Motor</b>				
Number.	1	1	1	2
Phase	3			
RPM	3450			
HP, Compressor 1	7	7.5	10	6
Amps (RLA), Comp. 1	9.6	12.5	14.8	12.8
Amps (LRA), Comp. 1	84	100	130	100
HP, Compressor 2	N/A	N/A	N/A	6
Amps (RLA), Comp. 2	N/A	N/A	N/A	12.8
Amps (LRA), Comp. 2	N/A	N/A	N/A	100
<b>Condenser Motor</b>				
Number.	2			
Phase	1			
HP	1/5	1/5	1/3	3/4
Amps (FLA, each)	0.8	0.8	1.4	2.3
Amps (LRA, each)	1.4	1.4	2.4	4.9

NOTE: \*Unit operating voltage range is 414 – 506

## MCA and MCOP

Table 17: Unit MCA and MCOP Data

MPS Model Drive Package		Voltage								
		208/230			460			575		
		Low*	Medium	High	Low*	Medium	High	Low*	Medium	High
007D	MCA	41.0	44.0	44.0	17.0	19.0	19.0	13.0	14.0	14.0
	MCOP	60.0	60.0	60.0	25.0	25.0	25.0	15.0	20.0	20.0
008D	MCA	46.0	48.0	51.0	21.0	22.0	24.0	16.0	17.0	17.0
	MCOP	70.0	70.0	70.0	30.0	30.0	35.0	25.0	25.0	25.
010D	MCA	54.0	56.0	58.0	26.0	32.0	34.0	19.0	20.0	20.0
	MCOP	80.0	80.0	90.0	40.0	45.0	45.0	25.0	30.0	30.0
012D	MCA	70.0	75.0	—	34.0	37.0	—	25.0	27.0	—
	MCOP	90.0	90.0	—	40.0	45.0	—	30.0	30.0	—

NOTE: \*Low static option is a direct drive motor for models 003 and 004

## Auxiliary Heater Data

**Table 18: Auxiliary Heater Kits Characteristics and Application: 480V – 3 Phase**

Unit Model Number	Heater Kit Model No. . RXJJ-	Heater kW @ 480V	Heater Kit Fla	Unit Min. Ckt. Ampacity	Max. Fuse Or Ckt. Bkr. Size (Ckt. Bkr. Must Be HACR Type For USA)
"MPS-007D Low Static Drive"	NONE	—	—	17	25
	DD10CP	9.9	11.9	19	20
	DD15CP	14.4	17.3	26	30
	DD20CP	19.8	23.8	34	35
	DD30CP	28.8	34.6	48	50
	DD40CP	39.6	47.6	64	70
"MPS-007D Medium-High Static Drive"	NONE	—	—	19	25
	DD10CP	9.9	11.9	27	30
	DD15CP	14.4	17.3	33	35
	DD20CP	19.8	23.8	42	45
	DD30CP	28.8	34.6	55	60
	DD40CP	39.6	47.6	71	80
"MPS-008D Low Static Drive"	NONE	—	—	21	30
	DD10CP	9.9	11.9	21	25
	DD15CP	14.4	17.3	26	30
	DD20CP	19.8	23.8	35	35
	DD30CP	28.8	34.6	48	50
	DD40CP	39.6	47.6	64	70
"MPS-008D Medium-High Static Drive"	NONE	—	—	22-24	30-35
	DD10CP	9.9	11.9	27	30
	DD15CP	14.4	17.3	33	35
	DD20CP	19.8	23.8	42	45
	DD30CP	28.8	34.6	55	60
	DD40CP	39.6	47.6	71	80
"MPS-010D Low Static Drive"	NONE	—	—	26	40
	DD10CP	9.9	11.9	26	30
	DD15CP	14.4	17.3	27	30
	DD20CP	19.8	23.8	35	35
	DD30CP	28.8	34.6	49	50
	DD40CP	39.6	47.6	65	70
"MPS-010D Medium-High Static Drive"	NONE	—	—	32-34	45
	DD10CP	9.9	11.9	32-34	40
	DD15CP	14.4	17.3	35-37	40
	DD20CP	19.8	23.8	43-45	45-50
	DD30CP	28.8	34.6	56-59	60
	DD40CP	39.6	47.6	73-75	80
"MPS-012D Low Static Drive"	NONE	—	—	34	40
	DD10CP	9.9	11.9	34	40
	DD15CP	14.4	17.3	34	40
	DD20CP	19.8	23.8	37	40
	DD30CP	28.8	34.6	50	50
	DD40CP	39.6	47.6	66	70
"MPS-012D Medium Static Drive"	NONE	—	—	37	45
	DD10CP	9.9	11.9	37	45
	DD15CP	14.4	17.3	37	45
	DD20CP	19.8	23.8	40	45
	DD30CP	28.8	34.6	54	60
	DD40CP	39.6	47.6	70	70

# Dimensional Data

## Unit Dimensions

Figure 35: MPS 007D – 012D Dimensions

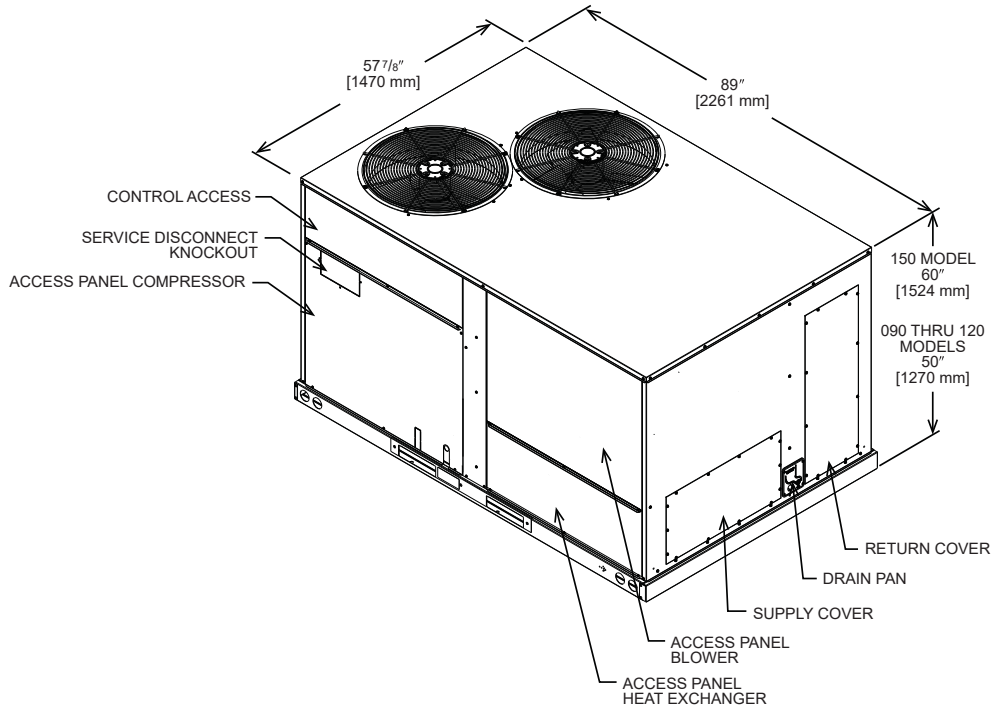

[ ] Designates Metric Conversions

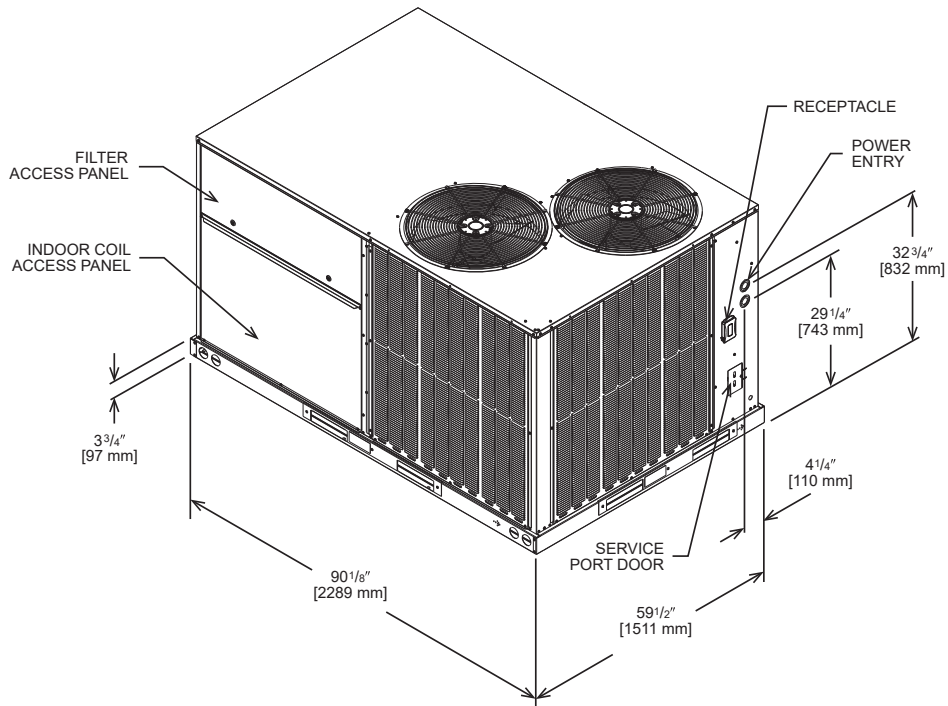

# Duct Dimensions

Figure 36: MPS 007D – 012D Horizontal Duct Dimensions Curb Dimensions

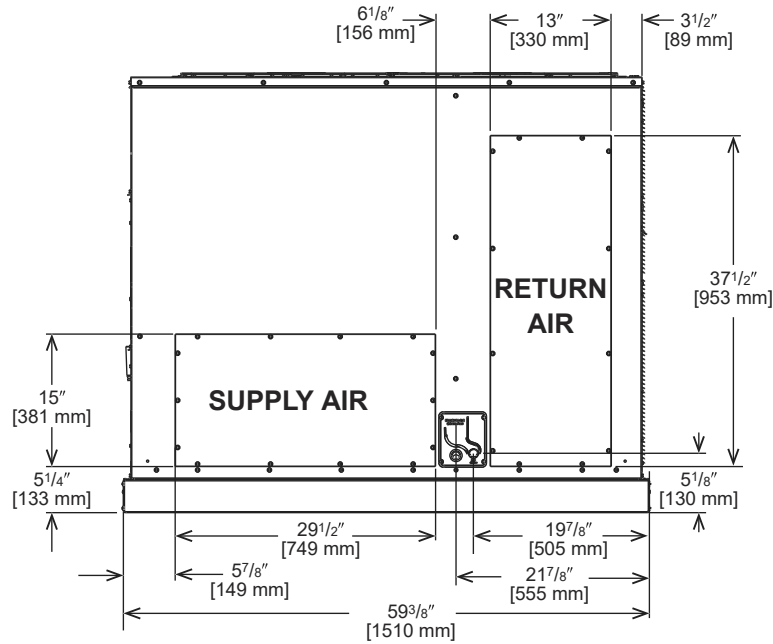

[ ] Designates Metric Conversions

# Curb Dimensions

Figure 37: MPS 007D – 012D Curb Dimensions

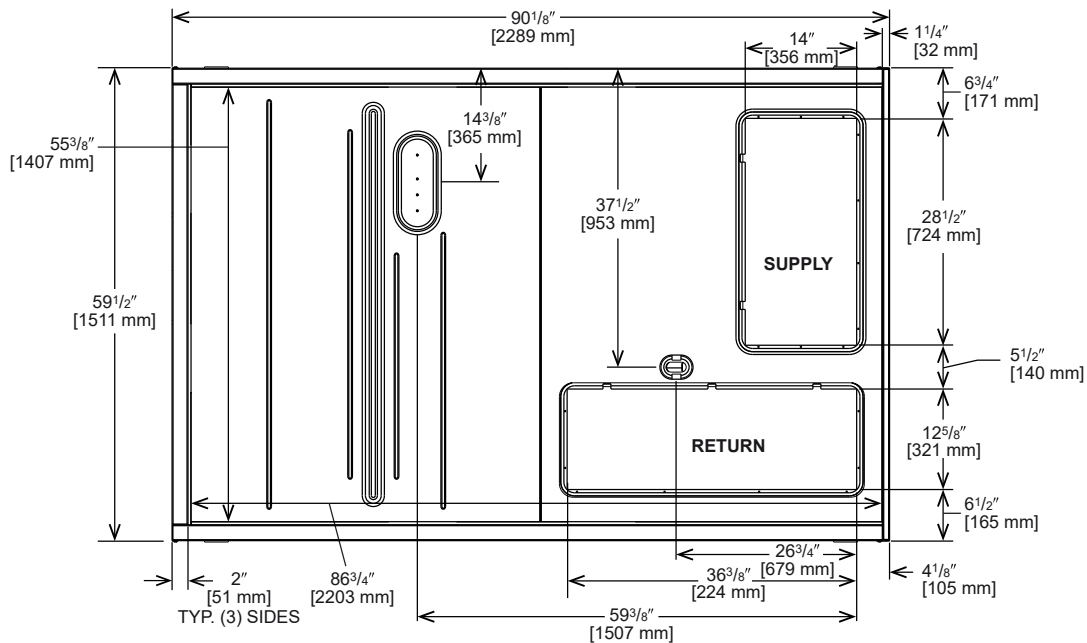

[ ] Designates Metric Conversions

# Performance Data

## Airflow Performance

Figure 38: Airflow Performance – MPS 007D

Air Flow CFM [L/s]	Model MPS 007D																																							
	External Static Pressure—Inches of Water [kPa]																																							
	0.1 [.02]	0.2 [.05]	0.3 [.07]	0.4 [.10]	0.5 [.12]	0.6 [.15]	0.7 [.17]	0.8 [.20]	0.9 [.22]	1.0 [.25]	1.1 [.27]	1.2 [.30]	1.3 [.32]	1.4 [.35]	1.5 [.37]	1.6 [.40]	1.7 [.42]	1.8 [.45]	1.9 [.47]	2.0 [.50]	0.1 [.02]	0.2 [.05]	0.3 [.07]	0.4 [.10]	0.5 [.12]	0.6 [.15]	0.7 [.17]	0.8 [.20]	0.9 [.22]	1.0 [.25]	1.1 [.27]	1.2 [.30]	1.3 [.32]	1.4 [.35]	1.5 [.37]	1.6 [.40]	1.7 [.42]	1.8 [.45]	1.9 [.47]	2.0 [.50]
2400 [1133]	—	—	551	782	585	814	619	848	652	885	684	926	717	969	748	1016	780	1065	810	1118	841	1174	870	1233	900	1294	929	1359	957	1427	985	1498	1012	1572	1039	1649	1065	1729	1091	1813
2500 [1180]	—	—	562	816	596	848	629	884	661	923	693	964	725	1009	756	1057	787	1108	817	1162	846	1219	876	1279	904	1343	933	1409	960	1478	987	1550	1014	1626	1040	1704	1066	1786	1092	1870
2600 [1227]	—	—	574	851	607	885	639	922	671	962	702	1006	733	1052	764	1101	794	1153	823	1209	852	1267	881	1329	909	1393	937	1461	964	1531	990	1605	1016	1682	1042	1762	1067	1844	1092	1930
2700 [1274]	553	857	585	889	618	925	650	963	681	1004	712	1049	742	1096	772	1147	801	1201	830	1258	858	1317	886	1380	914	1446	941	1515	967	1587	993	1662	1019	1740	1044	1821	1068	1905	1092	1993
2800 [1321]	565	896	597	930	629	966	660	1006	691	1049	721	1095	751	1144	780	1196	808	1251	837	1309	864	1370	892	1434	919	1501	945	1572	971	1645	996	1721	1021	1801	1045	1883	1069	1969	1093	2057
2900 [1368]	577	937	609	972	640	1010	670	1051	701	1096	730	1143	759	1193	788	1246	816	1303	843	1362	871	1425	897	1490	923	1559	949	1630	974	1705	999	1783	1023	1864	1047	1948	1070	2035	1093	2124
3000 [1416]	590	981	621	1017	651	1057	681	1099	710	1145	739	1193	768	1245	796	1300	823	1357	850	1418	877	1482	903	1549	928	1619	953	1692	978	1768	1002	1847	1026	1929	1049	2014	1072	2103	1094	2194
3100 [1463]	602	1027	633	1065	662	1105	692	1149	720	1196	749	1246	777	1299	804	1355	831	1414	857	1476	883	1541	908	1610	933	1681	958	1755	982	1833	1005	1913	1028	1997	1051	2083	1073	2173	1094	2266
3200 [1510]	615	1075	645	1114	674	1157	702	1202	731	1250	758	1301	785	1356	812	1413	838	1473	864	1537	889	1603	914	1673	938	1746	962	1821	986	1900	1008	1982	1031	2067	1053	2155	1074	2246	1095	2340
3300 [1557]	628	1126	657	1166	685	1210	713	1256	741	1306	768	1359	794	1414	820	1473	846	1535	871	1600	896	1668	920	1739	944	1813	967	1890	989	1970	1012	2053	1033	2139	1055	2229	1075	2321	1096	2416
3400 [1604]	640	1179	669	1221	697	1266	724	1314	751	1365	777	1419	803	1476	829	1536	854	1599	878	1665	902	1734	926	1807	949	1882	971	1960	993	2042	1015	2126	1036	2214	1057	2305	1077	2398	1097	2495
3500 [1652]	653	1235	681	1278	708	1324	735	1373	761	1425	787	1481	812	1539	837	1601	861	1665	885	1733	909	1803	932	1877	954	1954	976	2034	997	2116	1018	2202	1039	2291	1059	2383	1078	2478	1097	2576
3600 [1699]	666	1292	693	1337	720	1384	746	1435	771	1489	797	1545	821	1605	845	1668	869	1734	892	1803	915	1875	938	1950	959	2028	981	2109	1001	2193	1022	2280	1042	2371	1061	2464	1080	2560	1098	2660

NOTE: A/F—Drive left of 1st bold line, B/G—Drive in middle of bold lines, C/H—Drive right of 2nd bold line

Drive Package	A/F					B/G					C/H							
Motor H.P. [W]	2.0 [1491.4]					3.0 [2237.1]					3.0 [2237.1]							
Blower Sheave	AK84H					AK84H					AK84H							
Motor Sheave	1VL40*7/8					1VP50*7/8					1VP56*7/8							
Turns Open	0	1	<b>2</b>	3	4	5	0	1	2	3	4	<b>5</b>	0	1	2	3	4	5
RPM	767	721	<b>678</b>	635	590	548	992	949	908	866	823	<b>782</b>	1108	1067	1029	987	946	905

**NOTES:**

1. Factory sheave settings are shown in bold type.
2. Do not set motor sheave below minimum or maximum turns open shown.
3. Re-adjustment of sheave required to achieve rated airflow at AHRI minimum External Static Pressure
4. Add component resistance (below) to duct resistance to determine total External Static Pressure.

### Airflow Correction Factors – 7.5 Ton [26.4 kW]

Actual CFM [L/s]	2400 [1133]	2600 [1227]	2800 [1321]	3000 [1416]	3200 [1510]	3400 [1605]	3600 [1699]
Total MBH	0.96	0.97	0.98	0.99	1.00	1.01	1.02
Sensible MBH	0.89	0.92	0.95	0.97	1.00	1.03	1.06
Power kW	0.98	0.99	0.99	1.00	1.01	1.01	1.02

**NOTES:**

[ ] Designates Metric Conversions

1. Multiply correction factor times gross performance data.
2. Resulting sensible capacity cannot exceed total capacity.
3. Add component resistance to duct resistance to determine total external static pressure.
4. DNA = Data not Available.

### Component Air Resistance, IWC – 7.5 TON [26.4 kW]

Component	2400 [1133]	2600 [1227]	2800 [1321]	3000 [1416]	3200 [1510]	3400 [1605]	3600 [1699]
	Resistance – Inches Water [kPa]						
Wet Coil	0.04 [0.01]	0.05 [0.01]	0.06 [0.01]	0.07 [0.02]	0.07 [0.02]	0.08 [0.02]	0.09 [0.02]
Vertical Economizer 100% R.A. Damper Open	0.01 [0.00]	0.02 [0.01]	0.04 [0.01]	0.05 [0.01]	0.07 [0.02]	0.09 [0.02]	0.11 [0.03]

Figure 39: Side Airflow Performance – MPS 007D

Air Flow CFM [L/s]	Model MPS 007D																																								
	External Static Pressure—Inches of Water [kPa]																																								
	0.1 [.02]		0.2 [.05]		0.3 [.07]		0.4 [.10]		0.5 [.12]		0.6 [.15]		0.7 [.17]		0.8 [.20]		0.9 [.22]		1.0 [.25]		1.1 [.27]		1.2 [.30]		1.3 [.32]		1.4 [.35]		1.5 [.37]		1.6 [.40]		1.7 [.42]		1.8 [.45]		1.9 [.47]		2.0 [.50]		
RPM	W	RPM	W	RPM	W	RPM	W	RPM	W	RPM	W	RPM	W	RPM	W	RPM	W	RPM	W	RPM	W	RPM	W	RPM	W	RPM	W	RPM	W	RPM	W	RPM	W	RPM	W	RPM	W	RPM	W	RPM	W
2700 [1274]	—	—	561	894	596	934	631	975	665	1018	698	1062	730	1108	762	1155	793	1203	823	1253	853	1304	882	1357	910	1411	937	1467	964	1524	990	1583	1015	1643	1039	1704	1063	1767	1086	1832	
2800 [1321]	—	—	573	927	608	969	642	1013	676	1058	708	1104	740	1152	771	1201	802	1252	832	1304	861	1358	889	1413	917	1470	943	1528	970	1587	995	1648	1020	1711	1044	1775	1067	1840	1090	1907	
2900 [1368]	—	—	586	964	620	1008	654	1054	687	1101	719	1150	750	1200	781	1252	811	1305	840	1360	869	1416	897	1473	924	1532	950	1593	976	1654	1001	1718	1025	1782	1048	1848	1071	1916	1093	1985	
3000 [1416]	564	959	599	1004	633	1051	666	1099	698	1149	730	1200	761	1253	791	1307	820	1362	849	1419	877	1477	904	1537	931	1598	957	1661	982	1725	1006	1791	1030	1858	1053	1926	1075	1996	1097	2067	
3100 [1463]	578	1001	612	1048	645	1098	678	1148	710	1200	741	1254	771	1308	801	1365	830	1423	858	1482	886	1542	912	1605	939	1668	964	1733	989	1800	1012	1868	1036	1937	1058	2008	1080	2080	1101	2154	
3200 [1510]	592	1046	625	1096	658	1148	690	1201	721	1255	752	1311	782	1368	811	1427	840	1487	867	1548	894	1611	921	1676	946	1742	971	1809	995	1878	1019	1948	1041	2020	1063	2093	1085	2168	1105	2244	
3300 [1557]	605	1096	638	1148	671	1202	702	1257	733	1314	763	1372	793	1432	821	1493	849	1555	877	1619	903	1684	929	1751	954	1819	979	1889	1002	1960	1025	2033	1047	2107	1069	2182	1090	2259	1110	2337	
3400 [1604]	619	1149	652	1204	684	1260	715	1317	745	1376	775	1437	804	1499	832	1562	860	1627	886	1693	912	1761	938	1830	962	1900	986	1972	1009	2046	1032	2121	1053	2197	1074	2275	1095	2354	1114	2435	
3500 [1652]	634	1206	666	1263	697	1322	728	1382	758	1443	787	1506	815	1570	843	1635	870	1702	896	1771	922	1841	946	1912	970	1985	994	2060	1017	2135	1038	2213	1060	2291	1080	2371	1100	2453	1119	2536	
3600 [1699]	648	1267	680	1326	711	1387	741	1449	770	1513	799	1578	827	1645	854	1713	880	1782	906	1853	931	1925	955	1999	979	2074	1002	2151	1024	2229	1045	2308	1066	2389	1086	2472	1105	2556	1124	2641	
3700 [1746]	663	1332	694	1393	724	1456	754	1521	783	1587	811	1654	838	1723	865	1793	891	1865	916	1938	941	2013	965	2089	988	2167	1010	2246	1032	2326	1053	2408	1073	2491	1092	2576	1111	2662	1129	2750	
3800 [1793]	678	1400	708	1464	738	1529	767	1596	795	1665	823	1734	850	1805	876	1878	902	1952	926	2028	951	2105	974	2183	996	2263	1018	2344	1039	2427	1060	2511	1080	2597	1099	2684	1117	2772	1134	2862	
3900 [1840]	693	1472	723	1538	752	1606	781	1675	808	1746	836	1818	862	1892	888	1966	913	2043	937	2121	961	2200	983	2281	1005	2363	1027	2447	1048	2532	1067	2618	1087	2706	1105	2796	1123	2886	1140	2979	
4000 [1888]	708	1548	737	1617	766	1687	794	1758	822	1831	848	1906	874	1981	900	2059	924	2137	948	2218	971	2299	993	2382	1015	2467	1036	2553	1056	2640	1075	2729	1094	2819	1112	2911	1129	3004	1146	3099	
4100 [1935]	723	1628	752	1699	781	1771	808	1845	835	1920	861	1997	887	2075	911	2155	935	2236	959	2318	981	2402	1003	2488	1024	2574	1045	2663	1064	2752	1083	2844	1101	2936	1119	3030	1136	3126	1152	3223	

NOTE: A/F-Drive left of 1st bold line, B/G-Drive in middle of bold lines, C/H-Drive right of 2nd bold line.

Drive Package	A/F										B/G										C/H									
Motor H.P. [W]	2.0 [1491.4]										3.0 [2237.1]										3.0 [2237.1]									
Blower Sheave	AK79H										AK79H										AK79H									
Motor Sheave	1VL40*7/8										1VP50*7/8										1VP56*7/8									
Turns Open	0	1	<b>2</b>	3	4	5	0	1	2	3	4	<b>5</b>	0	1	2	3	4	5	0	1	2	3	4	5						
RPM	804	758	<b>710</b>	661	616	559	1048	1003	959	914	872	<b>826</b>	1168	1128	1087	1044	1002	957												

- NOTES:
1. Factory sheave settings are shown in bold type.
  2. Do not set motor sheave below minimum or maximum turns open shown.
  3. Re-adjustment of sheave required to achieve rated airflow at AHRI minimum External Static Pressure
  4. Add component resistance (below) to duct resistance to determine total External Static Pressure.

Airflow Correction Factors – 7.5 Ton [26.4 kW]

Actual CFM [L/s]	2400 [1133]	2600 [1227]	2800 [1321]	3000 [1416]	3200 [1510]	3400 [1605]	3600 [1699]
Total MBH	0.96	0.97	0.98	0.99	1.00	1.01	1.02
Sensible MBH	0.89	0.92	0.95	0.97	1.00	1.03	1.06
Power kW	0.98	0.99	0.99	1.00	1.01	1.01	1.02

- NOTES:
- [ ] Designates Metric Conversions
1. Multiply correction factor times gross performance data.
  2. Resulting sensible capacity cannot exceed total capacity.
  3. Add component resistance to duct resistance to determine total external static pressure.
  4. DNA = Data not Available.

Component Air Resistance, IWC – 7.5 TON [26.4 kW]

Component	2400 [1133]	2600 [1227]	2800 [1321]	3000 [1416]	3200 [1510]	3400 [1605]	3600 [1699]
Resistance – Inches Water [kPa]							
Wet Coil	0.04 [0.01]	0.05 [0.01]	0.06 [0.01]	0.07 [0.02]	0.07 [0.02]	0.08 [0.02]	0.09 [0.02]
Vertical Economizer 100% R.A. Damper Open	0.01 [0.00]	0.02 [0.01]	0.04 [0.01]	0.05 [0.01]	0.07 [0.02]	0.09 [0.02]	0.11 [0.03]

Figure 40: Airflow Performance – MPS 008D

Air Flow CFM [L/s]	Model MPS 008D																																								
	External Static Pressure—Inches of Water [kPa]																																								
	0.1 [.02]		0.2 [.05]		0.3 [.07]		0.4 [.10]		0.5 [.12]		0.6 [.15]		0.7 [.17]		0.8 [.20]		0.9 [.22]		1.0 [.25]		1.1 [.27]		1.2 [.30]		1.3 [.32]		1.4 [.35]		1.5 [.37]		1.6 [.40]		1.7 [.42]		1.8 [.45]		1.9 [.47]		2.0 [.50]		
RPM	W	RPM	W	RPM	W	RPM	W	RPM	W	RPM	W	RPM	W	RPM	W	RPM	W	RPM	W	RPM	W	RPM	W	RPM	W	RPM	W	RPM	W	RPM	W	RPM	W	RPM	W	RPM	W	RPM	W	RPM	W
2700 [1274]	—	—	561	894	596	934	631	975	665	1018	698	1062	730	1108	762	1155	793	1203	823	1253	853	1304	882	1357	910	1411	937	1467	964	1524	990	1583	1015	1643	1039	1704	1063	1767	1086	1832	
2800 [1321]	—	—	573	927	608	969	642	1013	676	1058	708	1104	740	1152	771	1201	802	1252	832	1304	861	1358	889	1413	917	1470	943	1528	970	1587	995	1648	1020	1711	1044	1775	1067	1840	1090	1907	
2900 [1368]	—	—	586	964	620	1008	654	1054	687	1101	719	1150	750	1200	781	1252	811	1305	840	1360	869	1416	897	1473	924	1532	950	1593	976	1654	1001	1718	1025	1782	1048	1848	1071	1916	1093	1985	
3000 [1416]	564	959	599	1004	633	1051	666	1099	698	1149	730	1200	761	1253	791	1307	820	1362	849	1419	877	1477	904	1537	931	1598	957	1661	982	1725	1006	1791	1030	1858	1053	1926	1075	1996	1097	2067	
3100 [1463]	578	1001	612	1048	645	1098	678	1148	710	1200	741	1254	771	1308	801	1365	830	1423	858	1482	886	1542	912	1605	939	1668	964	1733	989	1800	1012	1868	1036	1937	1058	2008	1080	2080	1101	2154	
3200 [1510]	592	1046	625	1096	658	1148	690	1201	721	1255	752	1311	782	1368	811	1427	840	1487	867	1548	894	1611	921	1676	946	1742	971	1809	995	1878	1019	1948	1041	2020	1063	2093	1085	2168	1105	2244	
3300 [1557]	605	1096	638	1148	671	1202	702	1257	733	1314	763	1372	793	1432	821	1493	849	1555	877	1619	903	1684	929	1751	954	1819	979	1889	1002	1960	1025	2033	1047	2107	1069	2182	1090	2259	1110	2337	
3400 [1604]	619	1149	652	1204	684	1260	715	1317	745	1376	775	1437	804	1499	832	1562	860	1627	886	1693	912	1761	938	1830	962	1900	986	1972	1009	2046	1032	2121	1053	2197	1074	2275	1095	2354	1114	2435	
3500 [1652]	634	1206	666	1263	697	1322	728	1382	758	1443	787	1506	815	1570	843	1635	870	1702	896	1771	922	1841	946	1912	970	1985	994	2060	1017	2135	1038	2213	1060	2291	1080	2371	1100	2453	1119	2536	
3600 [1699]	648	1267	680	1326	711	1387	741	1449	770	1513	799	1578	827	1645	854	1713	880	1782	906	1853	931	1925	955	1999	979	2074	1002	2151	1024	2229	1045	2308	1066	2389	1086	2472	1105	2556	1124	2641	
3700 [1746]	663	1332	694	1393	724	1456	754	1521	783	1587	811	1654	838	1723	865	1793	891	1865	916	1938	941	2013	965	2089	988	2167	1010	2246	1032	2326	1053	2408	1073	2491	1092	2576	1111	2662	1129	2750	
3800 [1793]	678	1400	708	1464	738	1529	767	1596	795	1665	823	1734	850	1805	876	1878	902	1952	926	2028	951	2105	974	2183	996	2263	1018	2344	1039	2427	1060	2511	1080	2597	1099	2684	1117	2772	1134	2862	
3900 [1840]	693	1472	723	1538	752	1606	781	1675	808	1746	836	1818	862	1892	888	1966	913	2043	937	2121	961	2200	983	2281	1005	2363	1027	2447	1048	2532	1067	2618	1087	2706	1105	2796	1123	2886	1140	2979	
4000 [1888]	708	1548	737	1617	766	1687	794	1758	822	1831	848	1906	874	1981	900	2059	924	2137	948	2218	971	2299	993	2382	1015	2467	1036	2553	1056	2640	1075	2729	1094	2819	1112	2911	1129	3004	1146	3099	
4100 [1935]	723	1628	752	1699	781	1771	808	1845	835	1920	861	1997	887	2075	911	2155	935	2236	959	2318	981	2402	1003	2488	1024	2574	1045	2663	1064	2752	1083	2844	1101	2936	1119	3030	1136	3126	1152	3223	

NOTE: A/F—Drive left of 1st bold line, B/G—Drive in middle of bold lines, C/H—Drive right of 2nd bold line.

Drive Package	A/F					B/G					C/H							
Motor H.P. [W]	2.0 [1491.4]					3.0 [2237.1]					3.0 [2237.1]							
Blower Sheave	AK79H					AK79H					AK79H							
Motor Sheave	1VL40*7/8					1VP50*7/8					1VP56*7/8							
Turns Open	0	1	<b>2</b>	3	4	5	0	1	2	3	4	<b>5</b>	0	1	2	3	4	5
RPM	804	758	<b>710</b>	661	616	559	1048	1003	959	914	872	<b>826</b>	1168	1128	1087	1044	1002	957

NOTES:

1. Factory sheave settings are shown in bold type.
2. Do not set motor sheave below minimum or maximum turns open shown.
3. Re-adjustment of sheave required to achieve rated airflow at AHRI minimum External Static Pressure
4. Add component resistance (below) to duct resistance to determine total External Static Pressure.

Airflow Correction Factors – 8.5 Ton [29.9 kW]

Actual CFM [L/s]	2700 [1274]	2900 [1368]	3100 [1463]	3300 [1557]	3500 [1652]	3700 [1746]	3900 [1840]	4100 [1935]
Total MBH	0.97	0.98	0.99	1.01	1.02	1.03	1.04	1.05
Sensible MBH	0.93	0.96	0.99	1.01	1.04	1.07	1.10	1.13
Power kW	0.99	0.99	1.00	1.00	1.01	1.02	1.02	1.03

NOTES:

[ ] Designates Metric Conversions

1. Multiply correction factor times gross performance data.
2. Resulting sensible capacity cannot exceed total capacity.
3. Add component resistance to duct resistance to determine total external static pressure.
4. DNA = Data not Available.

Component Air Resistance, IWC – 8.5 Ton [29.9 kW]

Component	2700 [1274]	2900 [1368]	3100 [1463]	3300 [1557]	3500 [1652]	3700 [1746]	3900 [1840]	4100 [1935]
	Resistance – Inches Water [kPa]							
Wet Coil	0.07 [0.02]	0.08 [0.02]	0.09 [0.02]	0.10 [0.03]	0.11 [0.03]	0.13 [0.03]	0.14 [0.04]	0.15 [0.04]
Vertical Economizer 100% R.A. Damper Open	0.03 [0.01]	0.04 [0.01]	0.06 [0.01]	0.08 [0.02]	0.10 [0.02]	0.12 [0.03]	0.15 [0.04]	0.17 [0.04]

Figure 41: Side Airflow Performance – MPS 008D

Air Flow CFM [L/s]	Model MPS 008D																																								
	External Static Pressure—Inches of Water [kPa]																																								
	0.1 [.02]		0.2 [.05]		0.3 [.07]		0.4 [.10]		0.5 [.12]		0.6 [.15]		0.7 [.17]		0.8 [.20]		0.9 [.22]		1.0 [.25]		1.1 [.27]		1.2 [.30]		1.3 [.32]		1.4 [.35]		1.5 [.37]		1.6 [.40]		1.7 [.42]		1.8 [.45]		1.9 [.47]		2.0 [.50]		
RPM	W	RPM	W	RPM	W	RPM	W	RPM	W	RPM	W	RPM	W	RPM	W	RPM	W	RPM	W	RPM	W	RPM	W	RPM	W	RPM	W	RPM	W	RPM	W	RPM	W	RPM	W	RPM	W	RPM	W	RPM	W
2700 [1274]	—	—	—	—	577	932	611	969	644	1009	677	1052	710	1098	742	1147	774	1199	806	1254	837	1312	868	1373	898	1437	929	1505	959	1575	988	1648	1017	1725	1046	1804	1074	1886	1102	1972	
2800 [1321]	—	—	556	926	589	962	622	1000	655	1042	687	1087	719	1134	751	1185	783	1239	814	1295	844	1355	875	1418	905	1484	934	1553	963	1624	992	1699	1021	1777	1049	1858	1077	1942	1105	2029	
2900 [1368]	—	—	568	958	601	995	633	1036	666	1079	697	1125	729	1174	760	1227	791	1282	821	1340	851	1402	881	1466	911	1533	940	1604	968	1677	997	1754	1025	1834	1052	1916	1080	2002	1107	2090	
3000 [1416]	—	—	580	994	613	1033	645	1074	676	1119	708	1167	738	1218	769	1272	799	1329	829	1389	859	1452	888	1518	917	1587	945	1659	973	1734	1001	1812	1029	1894	1056	1978	1082	2065	1109	2155	
3100 [1463]	561	996	593	1033	624	1073	656	1117	687	1163	718	1213	748	1265	778	1321	808	1379	837	1441	866	1506	895	1573	923	1644	951	1718	978	1794	1006	1874	1033	1957	1059	2043	1085	2132	1111	2224	
3200 [1510]	574	1037	605	1076	636	1118	667	1163	698	1211	728	1262	758	1316	787	1373	816	1434	845	1497	873	1563	902	1632	929	1705	957	1780	984	1858	1010	1940	1037	2024	1063	2112	1088	2202	1113	2296	
3300 [1557]	587	1082	618	1122	648	1166	679	1212	709	1262	738	1315	767	1371	796	1430	825	1491	853	1556	881	1624	908	1695	936	1769	962	1846	989	1926	1015	2009	1041	2095	1066	2184	1091	2276	1116	2372	
3400 [1604]	600	1130	630	1172	660	1217	690	1266	720	1317	749	1371	777	1429	806	1489	834	1553	861	1619	888	1689	915	1761	942	1837	968	1916	994	1997	1020	2082	1045	2170	1070	2260	1094	2354	1118	2451	
3500 [1652]	613	1182	643	1226	672	1273	702	1323	730	1376	759	1432	787	1491	815	1553	842	1618	869	1686	896	1757	922	1831	948	1909	974	1989	999	2072	1024	2158	1049	2248	1073	2340	1097	2436	1121	2534	
3600 [1699]	626	1238	656	1283	685	1332	713	1383	741	1438	769	1495	797	1556	824	1620	851	1687	877	1756	904	1829	929	1905	955	1984	980	2066	1005	2151	1029	2238	1053	2329	1077	2423	1100	2520	1123	2621	
3700 [1746]	640	1297	668	1344	697	1394	725	1447	753	1504	780	1563	807	1625	833	1690	860	1759	886	1830	911	1905	937	1982	961	2063	986	2146	1010	2233	1034	2322	1057	2415	1081	2510	1103	2609	1126	2711	
3800 [1793]	653	1360	681	1409	709	1460	737	1515	764	1573	790	1634	817	1698	843	1765	869	1835	894	1908	919	1984	944	2063	968	2145	992	2230	1016	2318	1039	2410	1062	2504	1084	2601	1107	2701	1128	2805	
3900 [1840]	667	1426	694	1477	721	1530	748	1587	775	1646	801	1709	827	1774	852	1843	878	1914	902	1989	927	2067	951	2147	975	2231	998	2318	1021	2408	1044	2500	1066	2596	1088	2695	1110	2797	1131	2902	
4000 [1888]	680	1496	707	1548	734	1604	760	1662	786	1723	812	1787	837	1854	862	1924	887	1998	911	2074	935	2153	958	2235	981	2321	1004	2409	1027	2501	1049	2595	1071	2693	1092	2793	1113	2897	1134	3003	
4100 [1935]	694	1570	720	1624	746	1681	772	1740	797	1803	822	1869	847	1938	872	2009	896	2084	919	2162	943	2243	965	2327	988	2414	1010	2504	1032	2597	1054	2693	1075	2792	1096	2895	1116	3000	1137	3108	

NOTE: A/F-Drive left of 1st bold line, B/G-Drive in middle of bold lines, C/H-Drive right of 2nd bold line.

Drive Package	A/F					B/G					C/H							
Motor H.P. [W]	2.0 [1491.4]					3.0 [2237.1]					3.0 [2237.1]							
Blower Sheave	AK79H					AK79H					AK79H							
Motor Sheave	1VL40*7/8					1VP50*7/8					1VP56*7/8							
Turns Open	0	1	<b>2</b>	3	4	5	0	1	2	3	4	<b>5</b>	0	1	2	3	4	5
RPM	800	754	<b>707</b>	662	616	555	1048	1005	960	916	870	<b>827</b>	1170	1126	1085	1044	1000	956

NOTES:

1. Factory sheave settings are shown in bold type.
2. Do not set motor sheave below minimum or maximum turns open shown.
3. Re-adjustment of sheave required to achieve rated airflow at AHRI minimum External Static Pressure.
4. Add component resistance (below) to duct resistance to determine total External Static Pressure.

Airflow Correction Factors – 8.5 Ton [29.9 kW]

Actual CFM [L/s]	2700 [1274]	2900 [1368]	3100 [1463]	3300 [1557]	3500 [1652]	3700 [1746]	3900 [1840]	4100 [1935]
Total MBH	0.97	0.98	0.99	1.01	1.02	1.03	1.04	1.05
Sensible MBH	0.93	0.96	0.99	1.01	1.04	1.07	1.10	1.13
Power kW	0.99	0.99	1.00	1.00	1.01	1.02	1.02	1.03

Component Air Resistance, IWC – 8.5 Ton [29.9 kW]

Component	2700 [1274]	2900 [1368]	3100 [1463]	3300 [1557]	3500 [1652]	3700 [1746]	3900 [1840]	4100 [1935]
	Resistance – Inches Water [kPa]							
Wet Coil	0.07 [0.02]	0.08 [0.02]	0.09 [0.02]	0.10 [0.03]	0.11 [0.03]	0.13 [0.03]	0.14 [0.04]	0.15 [0.04]
Vertical Economizer 100% R.A. Damper Open	0.03 [0.01]	0.04 [0.01]	0.06 [0.01]	0.08 [0.02]	0.10 [0.02]	0.12 [0.03]	0.15 [0.04]	0.17 [0.04]

NOTES:

[ ] Designates Metric Conversions

1. Multiply correction factor times gross performance data.
2. Resulting sensible capacity cannot exceed total capacity.
3. Add component resistance to duct resistance to determine total external static pressure.
4. DNA = Data not Available.



Figure 43: Side Airflow Performance – MPS 010D

Air Flow CFM [L/s]	Model MPS 010D																																										
	External Static Pressure—Inches of Water [kPa]																																										
	0.1 [0.02]		0.2 [0.05]		0.3 [0.07]		0.4 [0.10]		0.5 [0.12]		0.6 [0.15]		0.7 [0.17]		0.8 [0.20]		0.9 [0.22]		1.0 [0.25]		1.1 [0.27]		1.2 [0.30]		1.3 [0.32]		1.4 [0.35]		1.5 [0.37]		1.6 [0.40]		1.7 [0.42]		1.8 [0.45]		1.9 [0.47]		2.0 [0.50]				
RPM	W	RPM	W	RPM	W	RPM	W	RPM	W	RPM	W	RPM	W	RPM	W	RPM	W	RPM	W	RPM	W	RPM	W	RPM	W	RPM	W	RPM	W	RPM	W	RPM	W	RPM	W	RPM	W	RPM	W	RPM	W	RPM	W
3200 [1510]	575	1018	607	1057	637	1099	667	1143	697	1191	727	1240	756	1293	785	1348	814	1406	842	1466	870	1529	897	1595	924	1664	951	1735	978	1809	1004	1885	1030	1965	1055	2047	1080	2131	1105	2219			
3300 [1557]	588	1060	618	1101	649	1146	679	1192	708	1242	737	1294	766	1349	795	1406	823	1466	850	1529	878	1595	905	1663	932	1734	958	1808	984	1884	1010	1963	1035	2045	1060	2129	1085	2216	1109	2306			
3400 [1604]	600	1106	630	1150	660	1196	690	1245	719	1297	748	1352	776	1409	804	1469	832	1531	859	1597	886	1664	913	1735	939	1808	965	1884	990	1963	1016	2044	1040	2128	1065	2215	1089	2305	1113	2397			
3500 [1652]	613	1156	643	1202	672	1251	701	1302	730	1357	758	1413	786	1473	814	1535	841	1600	868	1668	894	1738	920	1811	946	1887	972	1965	997	2046	1022	2130	1046	2217	1070	2306	1094	2397	1117	2492			
3600 [1699]	626	1210	655	1258	684	1310	713	1364	741	1420	769	1479	796	1541	823	1606	850	1673	877	1743	903	1816	929	1892	954	1970	979	2050	1004	2134	1028	2220	1052	2309	1076	2400	1099	2494	1122	2591			
3700 [1746]	639	1268	668	1319	696	1373	724	1429	752	1488	779	1550	806	1614	833	1681	860	1751	886	1823	911	1898	937	1976	962	2056	986	2140	1011	2225	1035	2314	1058	2405	1081	2499	1104	2596	1127	2695			
3800 [1793]	652	1330	680	1384	708	1440	736	1498	763	1560	790	1624	817	1690	843	1760	869	1832	895	1907	920	1984	945	2064	970	2147	994	2233	1018	2321	1041	2412	1064	2505	1087	2602	1110	2701	1132	2802			
3900 [1840]	665	1397	693	1452	721	1511	748	1572	775	1636	801	1702	828	1771	854	1843	879	1917	904	1995	929	2075	954	2157	978	2242	1001	2330	1025	2421	1048	2514	1071	2610	1093	2709	1115	2810	1137	2914			
4000 [1888]	678	1467	706	1525	733	1586	760	1650	787	1716	813	1785	839	1856	864	1930	889	2007	914	2087	938	2169	962	2254	986	2341	1009	2432	1032	2525	1055	2620	1077	2719	1099	2820	1121	2923	1142	3030			
4100 [1935]	692	1542	719	1602	746	1666	772	1731	798	1800	824	1871	850	1945	875	2022	899	2101	923	2183	947	2267	971	2355	994	2445	1017	2537	1040	2633	1062	2731	1084	2831	1105	2935	1126	3041	1147	3150			
4200 [1982]	706	1621	732	1684	759	1749	785	1817	810	1888	836	1962	861	2038	885	2117	909	2199	933	2283	957	2370	980	2460	1003	2552	1025	2647	1047	2745	1069	2845	1091	2948	1112	3054	1132	3163	1153	3274			
4300 [2029]	720	1704	746	1769	772	1837	797	1907	823	1981	847	2057	872	2135	896	2217	920	2301	943	2387	966	2477	989	2569	1012	2664	1034	2761	1055	2861	1077	2964	1098	3069	1118	3178	1139	3288	1158	3402			
4400 [2076]	734	1791	760	1858	785	1928	810	2001	835	2077	859	2155	883	2237	907	2320	931	2407	954	2496	976	2587	999	2682	1020	2779	1042	2879	1063	2981	1084	3087	1105	3195	1125	3305	1145	3418	—	—			
4500 [2123]	748	1882	773	1952	798	2024	823	2100	847	2178	871	2259	895	2342	918	2428	941	2517	964	2608	986	2702	1008	2799	1030	2899	1051	3001	1071	3106	1092	3214	1112	3324	1132	3437	1151	3552	—	—			
4600 [2171]	762	1977	787	2049	812	2124	836	2202	860	2283	884	2366	907	2451	930	2540	952	2631	974	2725	996	2822	1018	2921	1039	3023	1059	3127	1080	3235	1100	3345	1120	3457	1139	3573	1158	3691	—	—			
4700 [2218]	777	2076	801	2151	826	2228	849	2309	873	2391	896	2477	919	2565	941	2656	963	2750	985	2846	1006	2945	1027	3046	1048	3151	1068	3258	1088	3367	1108	3480	1127	3595	1146	3712	—	—	—	—			
4800 [2265]	792	2180	816	2257	840	2337	863	2419	886	2504	909	2592	931	2683	953	2776	975	2872	996	2971	1017	3072	1037	3176	1058	3283	1077	3392	1097	3504	1116	3619	1135	3736	1153	3856	—	—	—	—			

NOTE: A/F-Drive left of 1st bold line, B/G-Drive in middle of bold lines, C/H-Drive right of 2nd bold line.

Drive Package	A/F					B/G					C/H							
Motor H.P. [W]	2.0 [1491.4]					3.0 [2237.1]					3.0 [2237.1]							
Blower Sheave	AK79H																	
Motor Sheave	1VL40*7/8					1VP50*7/8					1VP56*7/8							
Turns Open	0	1	<b>2</b>	3	4	5	0	1	2	3	4	<b>5</b>	0	1	2	3	4	5
RPM	798	753	<b>707</b>	663	616	556	1041	998	955	912	867	<b>824</b>	1155	1119	1078	1037	994	951

NOTES:

1. Factory sheave settings are shown in bold type.
2. Do not set motor sheave below minimum or maximum turns open shown.
3. Re-adjustment of sheave required to achieve rated airflow at AHRI minimum External Static Pressure
4. Add component resistance (below) to duct resistance to determine total External Static Pressure.

Airflow Correction Factors – 10.5 Ton [35.1 kW]

Actual CFM [L/s]	2700 [1274]	2900 [1368]	3100 [1463]	3300 [1557]	3500 [1652]	3700 [1746]	3900 [1840]	4100 [1935]
Total MBH	0.97	0.98	0.99	1.01	1.02	1.03	1.04	1.05
Sensible MBH	0.93	0.96	0.99	1.01	1.04	1.07	1.10	1.13
Power kW	0.99	0.99	1.00	1.00	1.01	1.02	1.02	1.03

NOTES:

[ ] Designates Metric Conversions

1. Multiply correction factor times gross performance data.
2. Resulting sensible capacity cannot exceed total capacity.
3. Add component resistance to duct resistance to determine total external static pressure.
4. DNA = Data not Available.

Component Air Resistance, IWC – 10.5 Ton [35.1 kW]

Component	2700 [1274]	2900 [1368]	3100 [1463]	3300 [1557]	3500 [1652]	3700 [1746]	3900 [1840]	4100 [1935]
	Resistance – Inches Water [kPa]							
Wet Coil	0.07 [0.02]	0.08 [0.02]	0.09 [0.02]	0.10 [0.03]	0.11 [0.03]	0.13 [0.03]	0.14 [0.04]	0.15 [0.04]
Vertical Economizer 100% R.A. Damper Open	0.03 [0.01]	0.04 [0.01]	0.06 [0.01]	0.08 [0.02]	0.10 [0.02]	0.12 [0.03]	0.15 [0.04]	0.17 [0.04]

Figure 44: Airflow Performance – MPS 012D

Air Flow CFM [L/s]	Model MPS 012D																																											
	External Static Pressure—Inches of Water [kPa]																																											
	0.1 [.02]		0.2 [.05]		0.3 [.07]		0.4 [.10]		0.5 [.12]		0.6 [.15]		0.7 [.17]		0.8 [.20]		0.9 [.22]		1.0 [.25]		1.1 [.27]		1.2 [.30]		1.3 [.32]		1.4 [.35]		1.5 [.37]		1.6 [.40]		1.7 [.42]		1.8 [.45]		1.9 [.47]		2.0 [.50]					
RPM	W	RPM	W	RPM	W	RPM	W	RPM	W	RPM	W	RPM	W	RPM	W	RPM	W	RPM	W	RPM	W	RPM	W	RPM	W	RPM	W	RPM	W	RPM	W	RPM	W	RPM	W	RPM	W	RPM	W	RPM	W			
4000 [1888]	766	1776	795	1806	824	1842	851	1883	878	1931	904	1985	929	2044	953	2110	976	2181	998	2259	1019	2342	1040	2431	1059	2526	1078	2627	1096	2734	1113	2847	1129	2966	1144	3091	1158	3221	1171	3358				
4100 [1935]	778	1820	807	1856	835	1897	862	1944	888	1997	913	2056	937	2120	961	2191	983	2268	1005	2350	1026	2439	1045	2533	1064	2634	1082	2740	1099	2852	1116	2970	1131	3094	1145	3224	1159	3360	1171	3502				
4200 [1982]	792	1875	820	1915	847	1961	873	2014	899	2072	923	2136	947	2206	969	2282	991	2364	1012	2451	1032	2545	1051	2645	1070	2750	1087	2862	1103	2979	1119	3102	1134	3232	1147	3367	1160	3508	1172	3655				
4300 [2029]	806	1938	833	1984	859	2036	885	2093	910	2156	934	2226	957	2301	979	2382	1000	2469	1020	2562	1040	2661	1058	2766	1076	2877	1092	2993	1108	3116	1123	3244	1137	3379	1150	3519	1162	3665	1174	3818				
4400 [2076]	820	2012	847	2063	873	2119	898	2182	922	2251	945	2325	967	2406	989	2492	1009	2584	1029	2682	1048	2787	1065	2897	1082	3013	1098	3134	1113	3262	1128	3396	1141	3536	1154	3681	1165	3833	1176	3990				
4500 [2123]	835	2095	861	2151	886	2213	911	2281	934	2355	957	2434	978	2520	999	2611	1019	2709	1038	2812	1056	2922	1073	3037	1090	3158	1105	3285	1119	3418	1133	3557	1146	3702	1158	3853	1168	4009	1178	4172				
4600 [2171]	851	2187	876	2249	901	2316	925	2389	947	2468	969	2553	990	2644	1010	2740	1030	2843	1048	2952	1065	3066	1082	3187	1097	3313	1112	3445	1126	3584	1139	3728	1151	3878	1162	4034	1172	4196	1182	4363				
4700 [2218]	867	2290	892	2356	916	2428	939	2507	961	2591	982	2681	1003	2777	1022	2879	1041	2987	1058	3101	1075	3220	1091	3346	1106	3478	1120	3615	1133	3759	1145	3908	1157	4063	1167	4224	1177	4391	1186	4564				
4800 [2265]	884	2401	908	2473	932	2551	954	2634	975	2723	996	2819	1016	2920	1034	3027	1052	3140	1069	3259	1085	3384	1101	3515	1115	3652	1128	3795	1141	3943	1153	4098	1163	4258	1173	4425	1182	4597	1190	4775				
4900 [2312]	902	2523	925	2599	948	2682	969	2771	990	2866	1010	2966	1029	3073	1047	3185	1065	3303	1081	3427	1097	3558	1111	3694	1125	3836	1138	3984	1149	4137	1160	4297	1170	4463	1180	4634	1188	4812	1195	4995				
5000 [2359]	920	2653	943	2736	965	2824	986	2917	1006	3017	1025	3123	1044	3235	1061	3352	1078	3476	1093	3605	1108	3741	1122	3882	1135	4029	1147	4182	1158	4341	1169	4506	1178	4677	1187	4854	1194	5036	1201	5225				
5100 [2407]	939	2794	961	2881	982	2974	1003	3073	1022	3179	1041	3289	1058	3406	1075	3529	1091	3658	1106	3792	1120	3933	1134	4079	1146	4232	1158	4390	1168	4554	1178	4725	1187	4901	1194	5083	1201	5270	1208	5464				
5200 [2454]	958	2944	980	3036	1000	3135	1020	3239	1039	3349	1057	3465	1074	3588	1090	3716	1105	3849	1120	3989	1133	4135	1146	4287	1158	4444	1168	4608	1178	4777	1187	4953	1196	5134	1203	5321	1209	5514	1215	5713				
5300 [2501]	978	3103	999	3201	1019	3305	1038	3414	1056	3530	1074	3651	1090	3778	1106	3912	1120	4051	1134	4196	1147	4347	1159	4504	1170	4666	1180	4835	1189	5010	1198	5190	1205	5377	1212	5569	1217	5767	1222	5972				
5400 [2548]	999	3273	1019	3376	1038	3484	1057	3599	1074	3720	1091	3846	1107	3979	1122	4117	1136	4261	1149	4412	1161	4568	1172	4730	1183	4898	1192	5072	1201	5252	1209	5438	1215	5629	1221	5827	1226	6030	—	—				
5500 [2595]	1020	3451	1040	3559	1058	3673	1076	3793	1093	3919	1109	4051	1124	4189	1138	4332	1152	4482	1164	4637	1176	4799	1186	4966	1196	5139	1205	5318	1213	5503	1220	5694	1226	5891	—	—	—	—	—	—				
5600 [2643]	1042	3640	1061	3753	1079	3872	1096	3997	1112	4128	1128	4265	1142	4408	1156	4557	1168	4712	1180	4872	1191	5039	1201	5212	1210	5390	1218	5574	1226	5765	—	—	—	—	—	—	—	—	—	—				
5700 [2690]	1064	3838	1083	3956	1100	4080	1117	4211	1132	4347	1147	4489	1161	4637	1174	4791	1186	4951	1197	5117	1207	5289	1216	5467	1225	5650	—	—	—	—	—	—	—	—	—	—	—	—	—	—	—	—		
5800 [2737]	1088	4045	1105	4169	1122	4298	1138	4434	1153	4575	1167	4723	1180	4876	1192	5035	1204	5200	1214	5371	1224	5548	—	—	—	—	—	—	—	—	—	—	—	—	—	—	—	—	—	—	—	—	—	—
5900 [2784]	1111	4262	1128	4391	1144	4526	1160	4666	1174	4813	1187	4966	1200	5124	1211	5289	1222	5459	—	—	—	—	—	—	—	—	—	—	—	—	—	—	—	—	—	—	—	—	—	—	—	—	—	—
6000 [2831]	1136	4489	1152	4623	1167	4763	1182	4909	1196	5061	1208	5218	1220	5382	—	—	—	—	—	—	—	—	—	—	—	—	—	—	—	—	—	—	—	—	—	—	—	—	—	—	—	—	—	—

NOTE: A/F-Drive left of the bold line, B/G-Drive right of bold lines.

Drive Package	A/F										B/G									
Motor H.P. [W]	3.0 [2237.1]										5.0 [3728.5]									
Blower Sheave	AK71H										AK79H									
Motor Sheave	1VL44*7/8										1VP60*1x1/8									
Turns Open	0	1	<b>2</b>	3	4	5	0	1	2	3	4	5	0	1	2	3	4	5		
RPM	1003	958	<b>912</b>	863	814	764	1220	1171	1127	1085	1039	<b>994</b>	1220	1171	1127	1085	1039	<b>994</b>		

- NOTES:
1. Factory sheave settings are shown in bold type.
  2. Do not set motor sheave below minimum or maximum turns open shown.
  3. Re-adjustment of sheave required to achieve rated airflow at AHRI minimum External Static Pressure
  4. Add component resistance (below) to duct resistance to determine total External Static Pressure.

Airflow Correction Factors – 12.5 Ton [43.9 kW]

Actual CFM [L/s]	4000 [1888]	4200 [1982]	4400 [2076]	4600 [2171]	4800 [2265]	5000 [2359]	5200 [2454]	5400 [2548]	5600 [2643]	5800 [2737]	6000 [2831]
Total MBH	1.01	1.02	1.03	1.04	1.05	1.06	1.07	1.08	1.09	1.10	1.11
Sensible MBH	1.03	1.06	1.08	1.11	1.13	1.16	1.18	1.21	1.23	1.26	1.28
Power kW	1.01	1.01	1.01	1.02	1.02	1.03	1.03	1.03	1.04	1.04	1.05

NOTES:

[ ] Designates Metric Conversions

1. Multiply correction factor times gross performance data.
2. Resulting sensible capacity cannot exceed total capacity.
3. Add component resistance to duct resistance to determine total external static pressure.
4. DNA = Data not Available.

Component Air Resistance, IWC – 12.5 Ton [43.9 kW]

Component	4000 [1888]	4200 [1982]	4400 [2076]	4600 [2171]	4800 [2265]	5000 [2359]	5200 [2454]	5400 [2548]	5600 [2643]	5800 [2737]	6000 [2831]
Resistance – Inches Water [kPa]											
Wet Coil	0.15 [0.04]	0.17 [0.04]	0.18 [0.05]	0.20 [0.05]	0.21 [0.05]	0.23 [0.06]	0.25 [0.06]	0.27 [0.07]	0.29 [0.07]	0.31 [0.08]	0.33 [0.08]
Vertical Economizer 100% R.A. Damper Open	0.16 [0.04]	0.19 [0.05]	0.21 [0.05]	0.24 [0.06]	0.28 [0.07]	0.31 [0.08]	0.35 [0.09]	0.38 [0.09]	0.42 [0.10]	0.46 [0.11]	0.51 [0.13]

Figure 45: Side Airflow Performance – MPS 012D

Air Flow CFM [L/s]	Model MPS 010D																																									
	External Static Pressure—Inches of Water [kPa]																																									
	0.1 [.02]		0.2 [.05]		0.3 [.07]		0.4 [.10]		0.5 [.12]		0.6 [.15]		0.7 [.17]		0.8 [.20]		0.9 [.22]		1.0 [.25]		1.1 [.27]		1.2 [.30]		1.3 [.32]		1.4 [.35]		1.5 [.37]		1.6 [.40]		1.7 [.42]		1.8 [.45]		1.9 [.47]		2.0 [.50]			
RPM	W	RPM	W	RPM	W	RPM	W	RPM	W	RPM	W	RPM	W	RPM	W	RPM	W	RPM	W	RPM	W	RPM	W	RPM	W	RPM	W	RPM	W	RPM	W	RPM	W	RPM	W	RPM	W	RPM	W	RPM	W	
4000 [1888]	—	—	791	1757	819	1824	846	1892	872	1961	897	2031	922	2101	946	2173	970	2245	993	2318	1015	2392	1036	2467	1057	2542	1077	2619	1096	2696	1115	2774	1133	2853	1150	2933	1167	3014	1183	3095		
4100 [1935]	782	1773	809	1841	836	1911	863	1982	888	2053	913	2125	937	2198	961	2272	984	2346	1006	2422	1027	2498	1048	2576	1068	2654	1088	2733	1106	2812	1124	2893	1142	2975	1158	3057	1174	3140	1189	3224		
4200 [1982]	801	1860	828	1932	854	2004	880	2077	905	2150	929	2225	952	2300	975	2377	997	2454	1019	2532	1040	2611	1060	2691	1079	2771	1098	2853	1116	2935	1133	3018	1150	3102	1166	3187	1181	3272	1196	3359		
4300 [2029]	819	1954	845	2028	871	2102	896	2177	920	2254	944	2331	967	2409	989	2488	1011	2567	1032	2648	1052	2729	1071	2811	1090	2894	1108	2978	1125	3063	1142	3149	1158	3235	1174	3323	1188	3411	1202	3500		
4400 [2076]	837	2053	863	2129	888	2207	912	2284	936	2363	959	2443	981	2523	1003	2605	1024	2687	1044	2770	1064	2854	1082	2938	1101	3024	1118	3110	1135	3197	1151	3286	1166	3375	1181	3464	1195	3555	1208	3646		
4500 [2123]	855	2159	880	2237	905	2317	929	2397	952	2479	974	2561	996	2644	1016	2727	1037	2812	1056	2897	1075	2984	1093	3071	1111	3159	1128	3248	1144	3338	1159	3428	1174	3520	1188	3612	1201	3705	1214	3799		
4600 [2171]	873	2270	898	2351	921	2433	944	2516	967	2600	988	2684	1009	2770	1030	2856	1049	2943	1068	3031	1086	3120	1104	3210	1121	3300	1137	3392	1152	3484	1167	3577	1181	3671	1195	3766	1207	3861	1219	3958		
4700 [2218]	891	2387	914	2471	938	2556	960	2641	982	2727	1003	2814	1023	2902	1043	2991	1062	3080	1080	3171	1097	3262	1114	3354	1130	3447	1146	3541	1161	3636	1175	3732	1188	3828	1201	3925	1213	4023	—	—		
4800 [2265]	908	2511	931	2597	954	2684	975	2772	996	2860	1017	2950	1036	3040	1055	3132	1074	3224	1091	3317	1108	3410	1124	3505	1140	3601	1155	3697	1169	3794	1182	3892	1195	3991	1207	4091	1219	4191	—	—		
4900 [2312]	925	2640	947	2729	969	2818	990	2908	1011	3000	1031	3092	1050	3184	1068	3278	1086	3373	1102	3468	1119	3565	1134	3662	1149	3760	1163	3859	1177	3958	1190	4059	1202	4160	1213	4262	—	—	—	—		
5000 [2359]	942	2775	964	2866	985	2958	1005	3051	1025	3145	1044	3239	1062	3335	1080	3431	1097	3528	1113	3626	1129	3725	1144	3824	1158	3925	1172	4026	1185	4128	1197	4231	1208	4335	1219	4440	—	—	—	—		
5100 [2407]	958	2916	979	3010	1000	3104	1020	3200	1039	3296	1057	3393	1075	3491	1092	3589	1108	3689	1124	3789	1139	3891	1153	3993	1167	4096	1180	4200	1192	4304	1204	4410	1214	4516	—	—	—	—	—	—		
5200 [2454]	975	3063	995	3160	1015	3256	1034	3354	1053	3453	1070	3552	1087	3653	1104	3754	1120	3856	1135	3959	1149	4063	1162	4167	1175	4273	1188	4379	1199	4486	1210	4594	1220	4703	—	—	—	—	—	—		
5300 [2501]	991	3217	1010	3315	1030	3415	1048	3515	1066	3616	1083	3718	1100	3821	1115	3924	1130	4029	1145	4134	1158	4241	1171	4348	1184	4456	1195	4564	1206	4674	1216	4785	—	—	—	—	—	—	—	—		
5400 [2548]	1006	3376	1026	3477	1044	3579	1062	3681	1079	3785	1096	3889	1111	3995	1126	4101	1141	4208	1155	4316	1168	4425	1180	4534	1192	4645	1203	4756	1213	4868	—	—	—	—	—	—	—	—	—	—		
5500 [2595]	1022	3541	1040	3644	1058	3749	1075	3854	1092	3960	1108	4067	1123	4175	1137	4283	1151	4393	1164	4503	1177	4614	1188	4726	1199	4839	1210	4953	1219	5068	—	—	—	—	—	—	—	—	—	—		
5600 [2643]	1037	3712	1055	3818	1072	3924	1089	4032	1105	4141	1120	4250	1134	4361	1148	4472	1161	4584	1174	4697	1185	4810	1196	4925	1207	5040	1216	5156	—	—	—	—	—	—	—	—	—	—	—	—		
5700 [2690]	1052	3888	1069	3997	1086	4106	1102	4217	1117	4328	1132	4440	1145	4552	1159	4666	1171	4780	1183	4896	1194	5012	1204	5129	1214	5247	—	—	—	—	—	—	—	—	—	—	—	—	—	—	—	
5800 [2737]	1067	4071	1083	4182	1099	4294	1115	4407	1129	4520	1143	4635	1156	4750	1169	4866	1181	4983	1192	5101	1202	5220	1212	5339	1221	5460	—	—	—	—	—	—	—	—	—	—	—	—	—	—	—	
5900 [2784]	1081	4260	1097	4374	1113	4488	1127	4603	1141	4719	1154	4836	1167	4954	1179	5073	1190	5192	1200	5312	1210	5433	1219	5555	—	—	—	—	—	—	—	—	—	—	—	—	—	—	—	—	—	—
6000 [2831]	1095	4455	1111	4571	1126	4688	1139	4805	1153	4924	1165	5043	1177	5164	1188	5285	1199	5407	1209	5529	1218	5653	—	—	—	—	—	—	—	—	—	—	—	—	—	—	—	—	—	—	—	—

NOTE: A/F—Drive left of the bold line, B/G—Drive right of bold lines.

Drive Package	A/F										B/G				
Motor H.P. [W]	3.0 [2237.1]										5.0 [3728.5]				
Blower Sheave	AK71H										AK79H				
Motor Sheave	1VL44*7/8										1VP60*1x1/8				
Turns Open	0	1	2	3	4	5	0	1	2	3	4	5			
RPM	1002	955	909	862	813	765	1208	1171	1127	1084	1038	995			

- NOTES:
1. Factory sheave settings are shown in bold type.
  2. Do not set motor sheave below minimum or maximum turns open shown.
  3. Re-adjustment of sheave required to achieve rated airflow at AHRI minimum External Static Pressure
  4. Add component resistance (below) to duct resistance to determine total External Static Pressure.

Airflow Correction Factors – 12.5 Ton [43.9 kW]

Actual CFM [L/s]	4000 [1888]	4200 [1982]	4400 [2076]	4600 [2171]	4800 [2265]	5000 [2359]	5200 [2454]	5400 [2548]	5600 [2643]	5800 [2737]	6000 [2831]
Total MBH	1.01	1.02	1.03	1.04	1.05	1.06	1.07	1.08	1.09	1.10	1.11
Sensible MBH	1.03	1.06	1.08	1.11	1.13	1.16	1.18	1.21	1.23	1.26	1.28
Power kW	1.01	1.01	1.01	1.02	1.02	1.03	1.03	1.03	1.04	1.04	1.05

- NOTES:
- [ ] Designates Metric Conversions
1. Multiply correction factor times gross performance data.
  2. Resulting sensible capacity cannot exceed total capacity.
  3. Add component resistance to duct resistance to determine total external static pressure.
  4. DNA = Data not Available.

Component Air Resistance, IWC – 12.5 Ton [43.9 kW]

Component	4000 [1888]	4200 [1982]	4400 [2076]	4600 [2171]	4800 [2265]	5000 [2359]	5200 [2454]	5400 [2548]	5600 [2643]	5800 [2737]	6000 [2831]
Resistance – Inches Water [kPa]											
Wet Coil	0.15 [0.04]	0.17 [0.04]	0.18 [0.05]	0.20 [0.05]	0.21 [0.05]	0.23 [0.06]	0.25 [0.06]	0.27 [0.07]	0.29 [0.07]	0.31 [0.08]	0.33 [0.08]
Vertical Economizer 100% R.A. Damper Open	0.16 [0.04]	0.19 [0.05]	0.21 [0.05]	0.24 [0.06]	0.28 [0.07]	0.31 [0.08]	0.35 [0.09]	0.38 [0.09]	0.42 [0.10]	0.46 [0.11]	0.51 [0.13]

**Table 19: Accessory Weights**

Accessory	Daikin Applied Part Number	Shipping Weight	Operating Weight
Economizer, Electromechanical Controls, 6 – 12 ton, Vertical	RXRD-01MDDAM3	86 [39.0]	57 [25.9]
Economizer, Electromechanical Controls, 6 – 12 ton, Horizontal	RXRD-01MDHAM3	84 [38.1]	55 [24.9]
Economizer, DDC Controls, 6 – 12 ton, Vertical	RXRD-01MDDBM3	86 [39.0]	57 [25.9]
Economizer, DDC Controls, 6 – 12 ton, Horizontal	RXRD-MDHBM3	84 [38.1]	55 [24.9]
OA damper, 6 – 12 ton, Manual	MXRF-ADA1	26 [12]	21 [10]
OA damper, Electromechanical Controls, 6 – 12 ton, Motorized	MXRF-ADB1	43 [19]	38 [17]
OA damper, DDC Controls, 6 – 12 ton, Motorized	MXRF-ADC4	43 [19]	38 [17]
Power Exhaust Kit, 6 – 12 Ton 208/230V	RXRX-CDF01C	58 [26.3]	48 [21.8]
Power Exhaust Kit, 6 – 12 Ton 460V	RXRX-CDF01D	50 [22.7]	44 [20.0]
Power Exhaust Kit, 6 – 12 Ton 575V	RXRX-CDF01Y	58 [26.3]	48 [21.8]
14" Roof Curb, 6 – 12 Ton	RXKG-DDD14	90 [41]	85 [39]
Receptacle Outlet	RXRX-BN01	N/A	N/A
Thermostat Guard	113130101	N/A	N/A
7-Day Programmable Stat	113129801	N/A	N/A
Ionization Smoke Detector	113126601	N/A	N/A
CO2 Sensor	RXRX-AR02	N/A	N/A
Dual Enthalpy Kit	RXRX-BV02	N/A	N/A

[ ] Designates Metric Conversions

# Non-DDC Economizer for Downflow Duct Install

## Use to Select Factory Installed Options Only

### RXRD-01MDDAM3—Single Enthalpy (Outdoor) and AXRD-SJCM3 Single Enthalpy with Smoke Detector

### RXXR-AR02—Optional Wall-Mounted CO<sub>2</sub> Sensor

- Features Honeywell controls
- Available factory installed or field accessory
- Gear driven direct drive actuator
- Fully modulating (0–100%)
- Low leakage dampers
- Slip-in design for easy installation
- Standard barometric relief damper
- Single enthalpy
- CO<sub>2</sub> input sensor available
- Field assembled hood ships with economizer
- Economizer ships complete for downflow duct application
- Field installed power exhaust available
- Prewired for smoke detector
- If connected to a Building Automation System (BAS), all economizer functions can be viewed on the (BAS) or 16 x 2 LCD screen
- If connected to thermostat, all economizer functions can be viewed on 16 x 2 LCD screen

Figure 46: Electromechanical Controls Downflow Economizer, MPS 007D – 012D

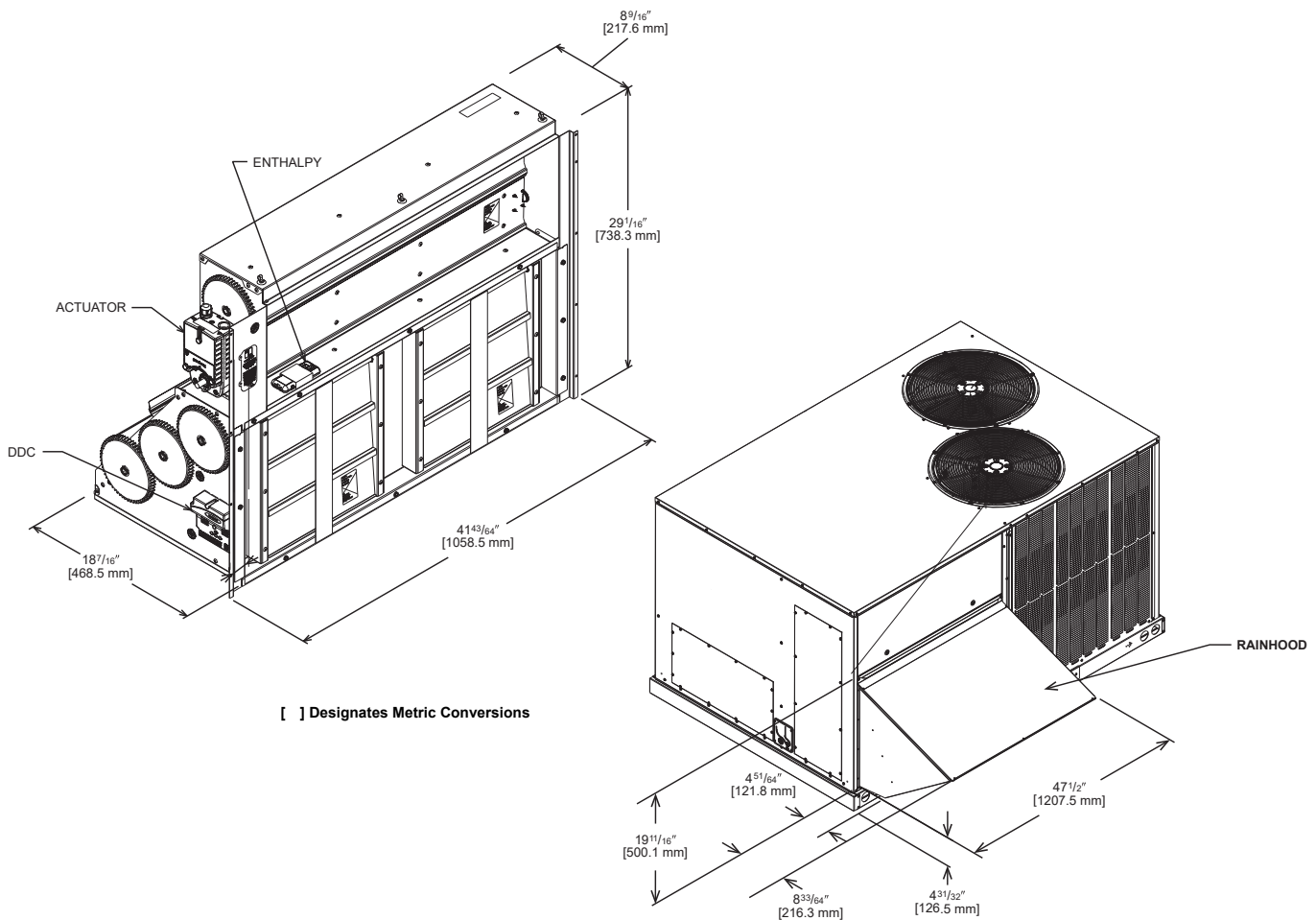

# Non-DDC Economizer for Horizontal Duct Install Field Installed Only

## RXRD-01DAH3—Single Enthalpy (Outdoor)

## RRX-AR02—Wall-mounted CO<sub>2</sub> Sensor

- Features Honeywell controls
- Available as a field installed accessory only
- Gear driven direct drive actuator
- Fully modulating (0–100%)
- Low leakage dampers
- Slip-in design for easy installation
- Standard barometric relief damper
- Single enthalpy
- CO<sub>2</sub> input sensor available
- Field assembled hood ships with economizer
- Economizer ships complete for horizontal duct application
- Field installed power exhaust available
- If connected to a Building Automation System (BAS), all economizer functions can be viewed on the (BAS) or 16 × 2 LCD screen
- If connected to thermostat, all economizer functions can be viewed on 16 × 2 LCD screen

Figure 47: Electromechanical Controls Horizontal Economizer, MPS 007D – 012D

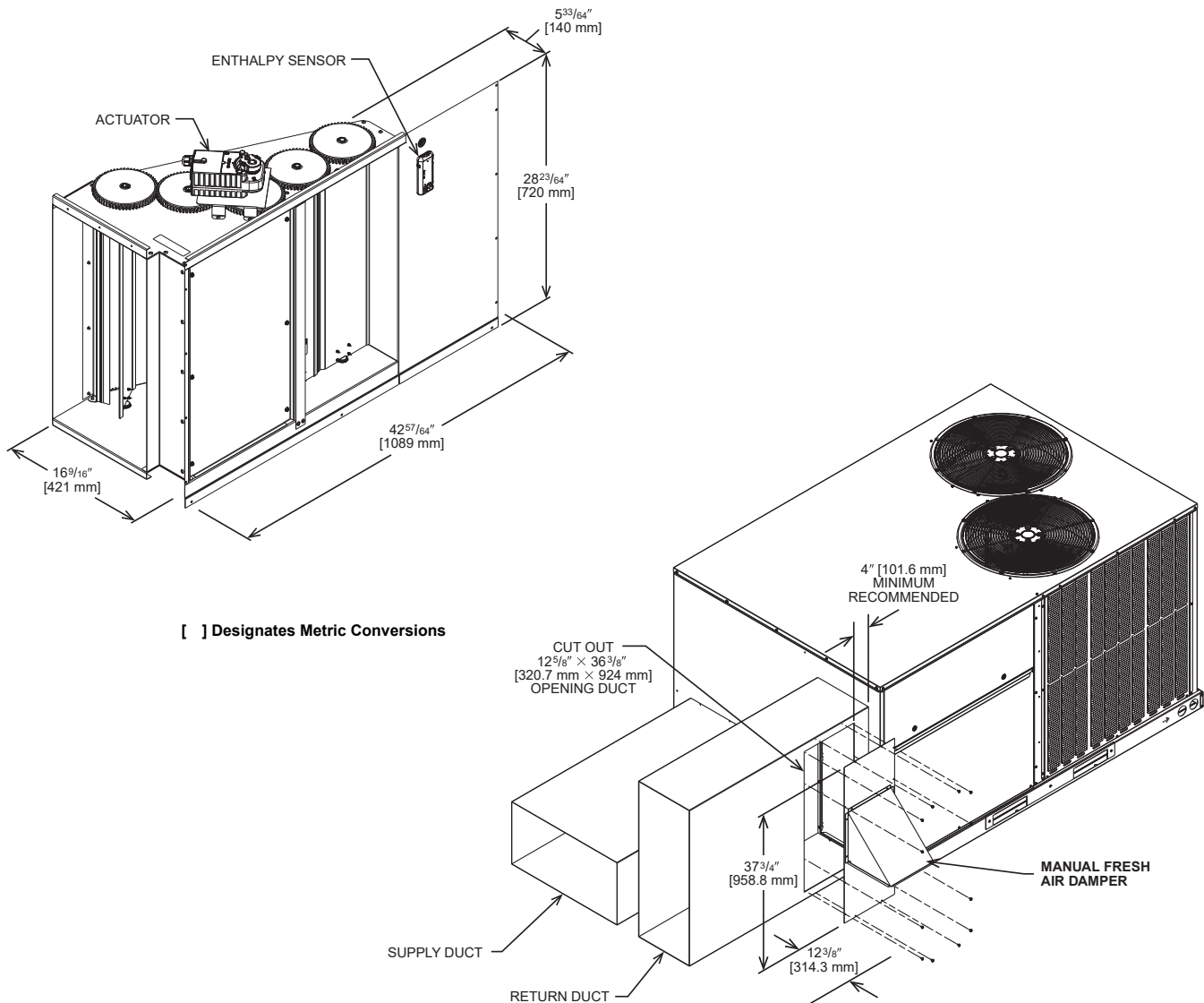

## DDC Economizer for Downflow Duct Install Use to Select Factory Installed Options Only

### RXRD-01MDDAM3—Single Enthalpy (Outdoor)

### RRX-AR02—Optional Wall-Mounted CO<sub>2</sub> Sensor

- Features Honeywell controls
- Available factory installed or field accessory
- Gear driven direct drive actuator
- Fully modulating (0–100%)
- Ultra low leak dampers meet California Title 24 requirements
- Slip-in design for easy installation
- Standard barometric relief damper
- Single enthalpy
- CO<sub>2</sub> input sensor available
- Field assembled hood ships with economizer
- Economizer ships complete for downflow duct application
- Field installed power exhaust available
- Prewired for smoke detector
- If connected to a Building Automation System (BAS), all economizer functions can be viewed on the (BAS), or 16 × 2 LCD screen
- If connected to thermostat, all economizer functions can be viewed on 16 × 2 LCD screen

Figure 48: Electromechanical Controls Downflow Economizer, MPS 007D – 012D

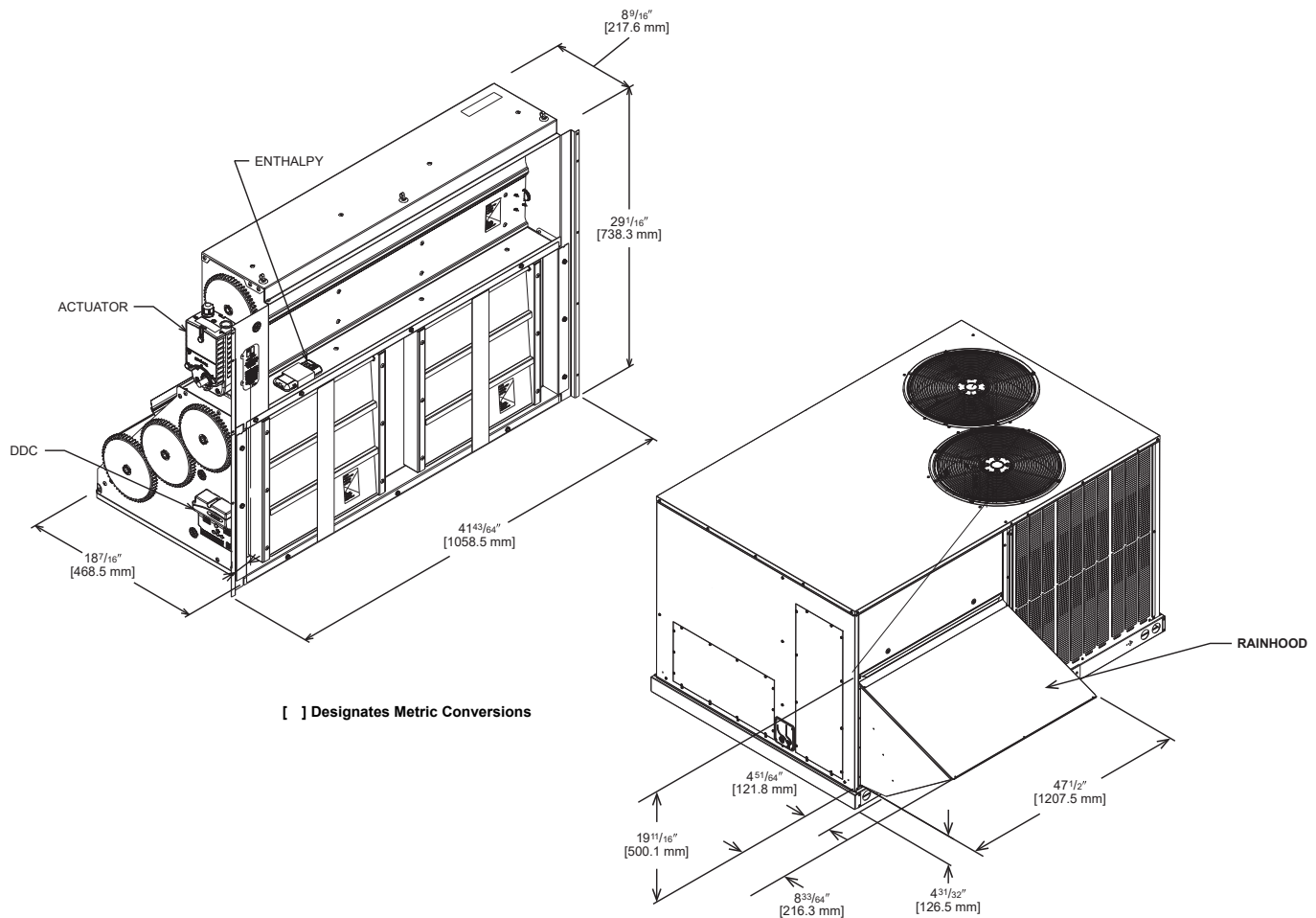

# DDC Economizer for Horizontal Duct Install

## Field Installed Only

### RXRD-01DAH3—Single Enthalpy (Outdoor)

### RXXR-AR02—Wall-mounted CO<sub>2</sub> Sensor

- Features Honeywell controls
- Available as a field installed accessory only
- Gear driven direct drive actuator
- Fully modulating (0–100%)
- Ultra low leak dampers meet California Title 24 requirements
- Slip-in design for easy installation
- Standard barometric relief damper
- Single enthalpy
- CO<sub>2</sub> input sensor available
- Field assembled hood ships with economizer
- Economizer ships complete for horizontal duct application
- Field installed power exhaust available
- If connected to a Building Automation System (BAS), all economizer functions can be viewed on the (BAS), or 16 × 2 LCD screen
- If connected to thermostat, all economizer functions can be viewed on 16 × 2 LCD screen

Figure 49: Electromechanical Controls Horizontal Economizer, MPS 007D – 012D

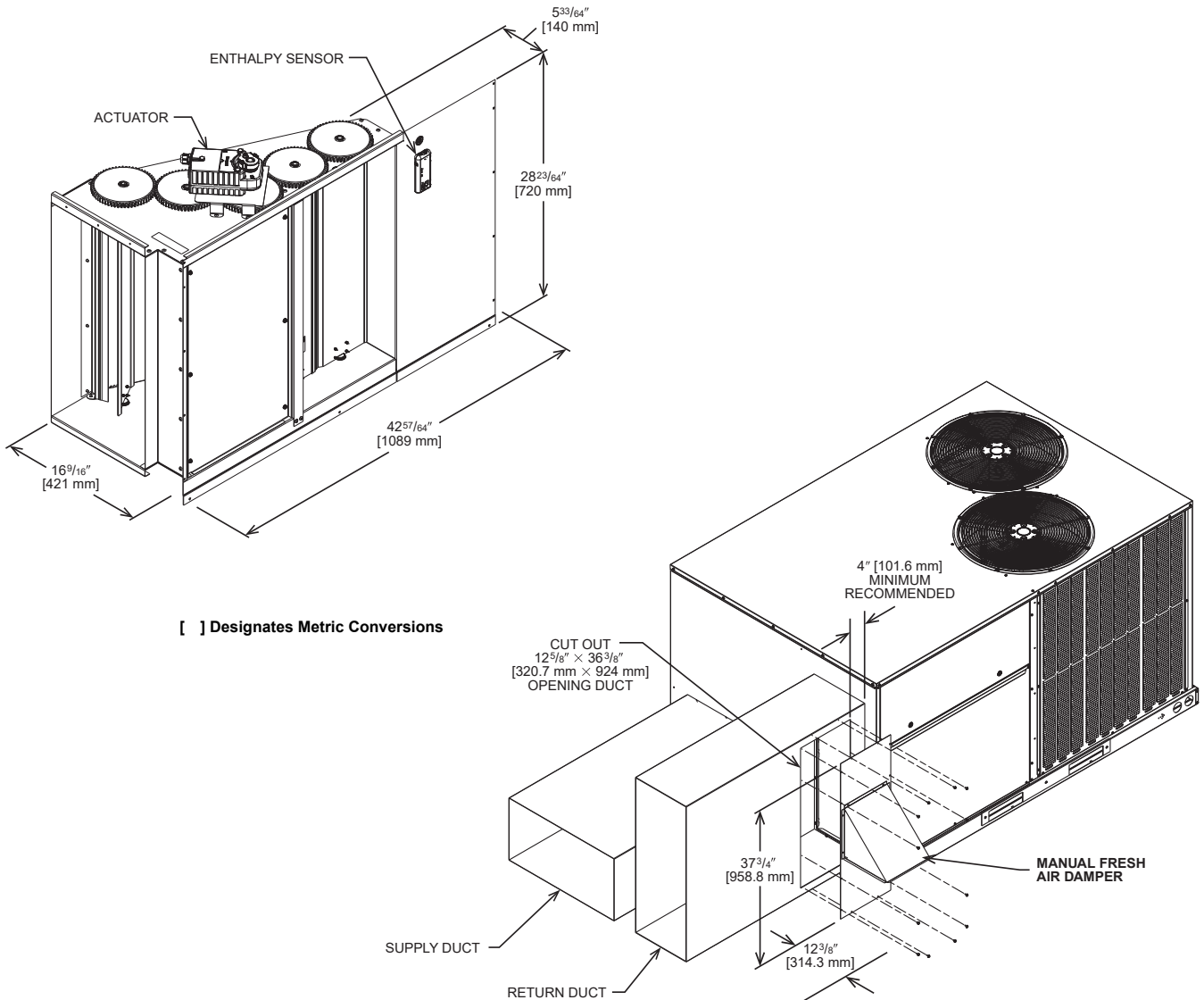

## Fresh Air Dampers and Power Exhaust

Power exhaust kit for RXRD-01MDDAM3, RXRD-01MDDBM3, RXRD-01MDHAM3, RXRD-01MDHBM3 economizers

RXXR-CDF01

Figure 50: Vertical Airflow Power Exhaust Economizer, MPS 007D – 012D

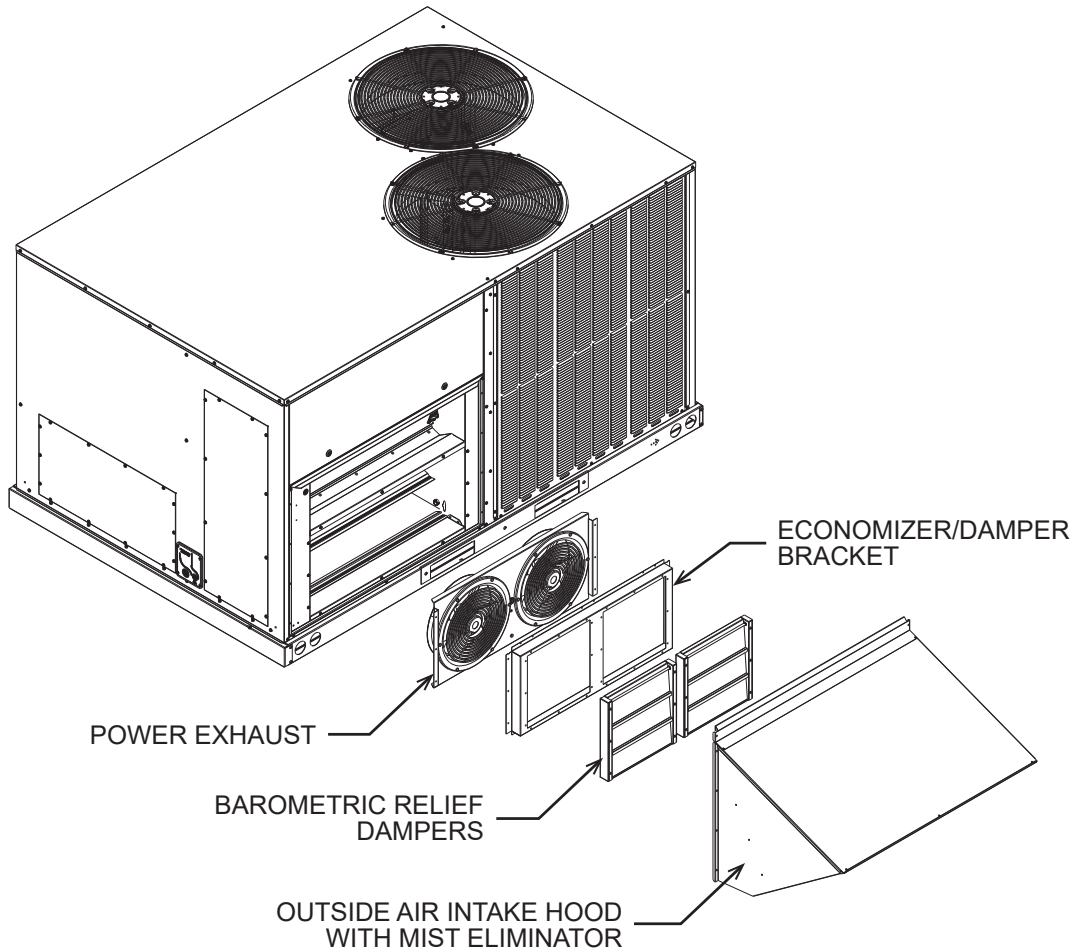

Figure 51: Horizontal Airflow Power Exhaust Economizer, MPS 007D – 012D

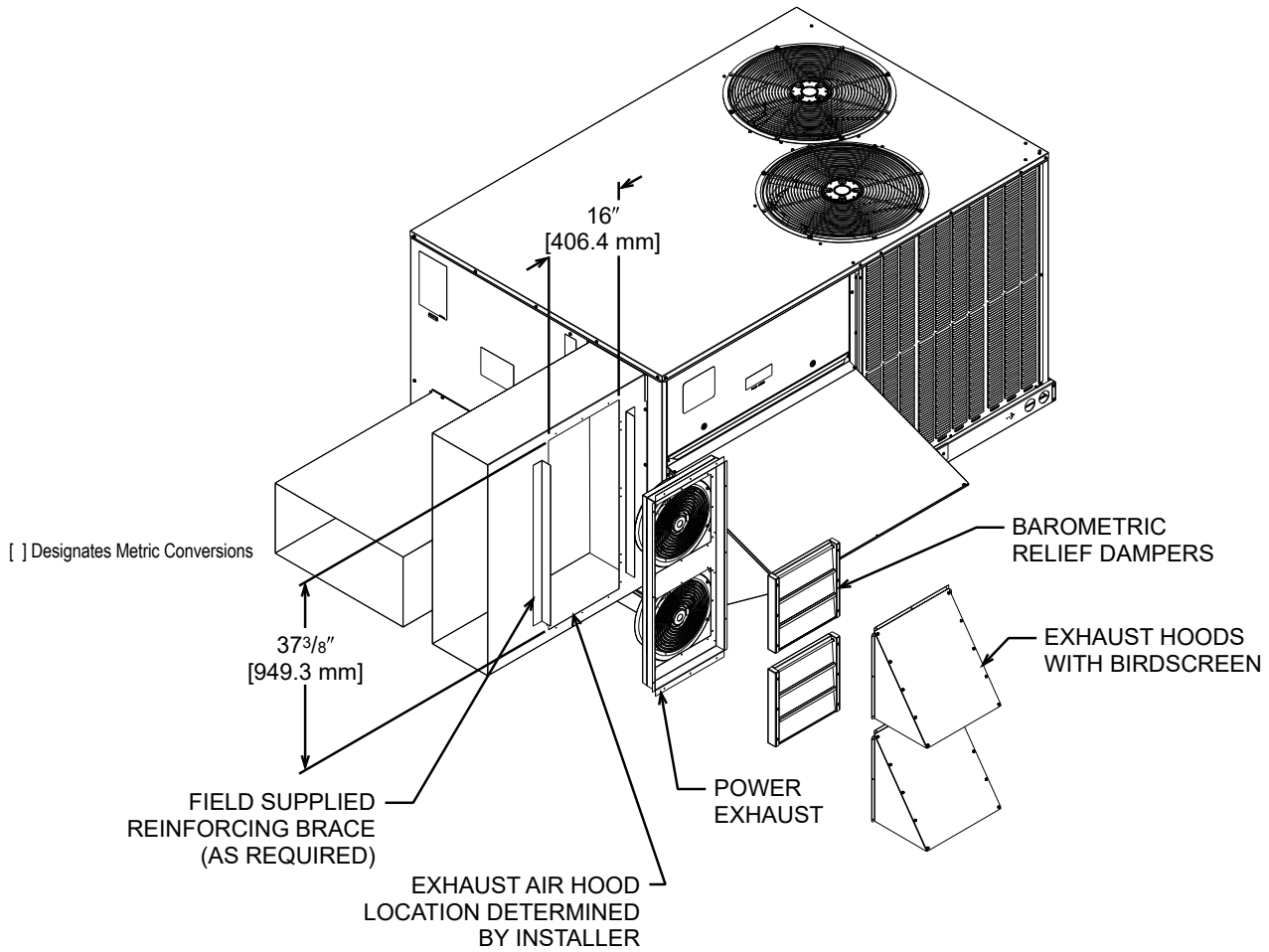

Table 20: Power Exhaust

Model Number	Number of Fans	Volts	Phase	HP (ea.)	High Speed		FLA (ea.)	LRA (ea.)
					CFM [L/s]	RPM		
RXRX-CDF01C	2	208-230	1	0.47	2200 [1038]	3000	1.55	1.1
RXRX-CDF01D	2	460	3	0.40	1970 [930]	2750	0.51	1.9

**NOTE:**

1. CFM is at 0" W.C. external static pressure.

# Fresh Air Damper

## Motorized Damper Kit

### RXRF-ADB1, RXRX-ADC 1 (Motor Kit for DDC Models), RXRX-AW04 (Modulating Motor Kit with position feedback for AXRF-KDA1)

- Features Honeywell Controls
- Gear driven direct drive actuator
- Fully modulating (0–100%)
- Low leakage dampers
- Slip-in design for easy installation
- Plug-in polarized 12-pin and 4-pin electrical connections
- Pre-configured—no field adjustments necessary
- CO<sub>2</sub> sensor input available for Demand Control Ventilation (DCV)
- All fresh air damper functions can be viewed at the RTU-C unit controller display
- If connected to a Building Automation System (BAS), all fresh air damper functions can be viewed on the (BAS)

Figure 52: Motorized Fresh Air Damper Kit, MPS 007D – 012D

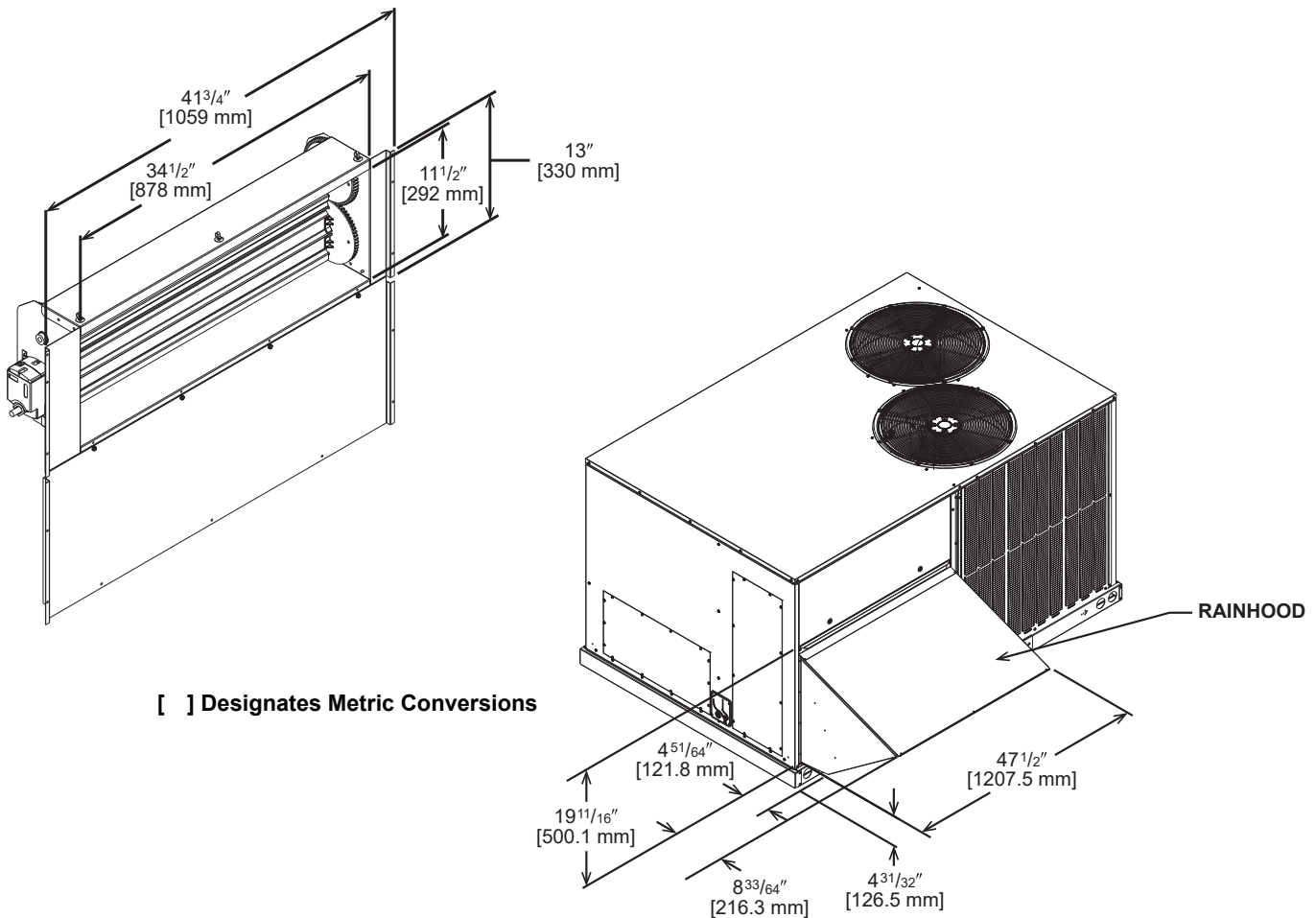

# Non-Motorized Damper Kit

## RXRF-ADA1

- Features Honeywell Controls
- Gear driven direct drive actuator
- Fully modulating (0–100%)
- Low leakage dampers
- Slip-in design for easy installation
- Plug-in polarized 12-pin and 4-pin electrical connections
- Pre-configured—no field adjustments necessary
- CO<sub>2</sub> sensor input available for Demand Control Ventilation (DCV)
- All fresh air damper functions can be viewed at the RTU-C unit controller display
- If connected to a Building Automation System (BAS), all fresh air damper functions can be viewed on the (BAS)

Figure 53: Non-Motorized Fresh Air Damper Kit, MPS 007D – 012D

### DOWNFLOW APPLICATION

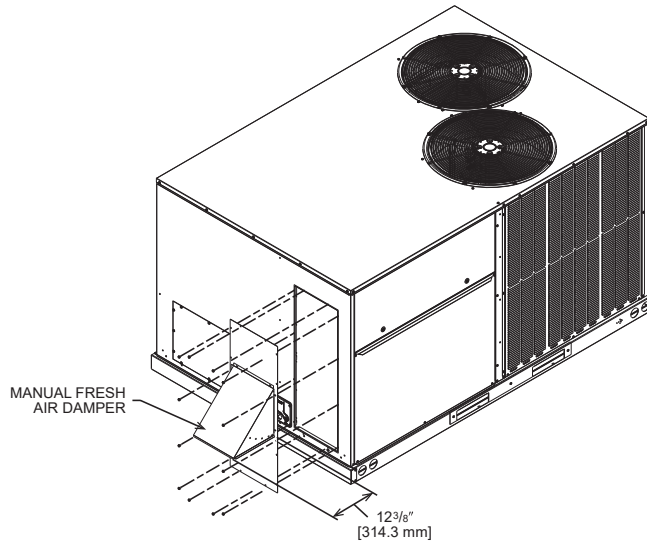

[ ] Designates Metric Conversions

### HORIZONTAL APPLICATION

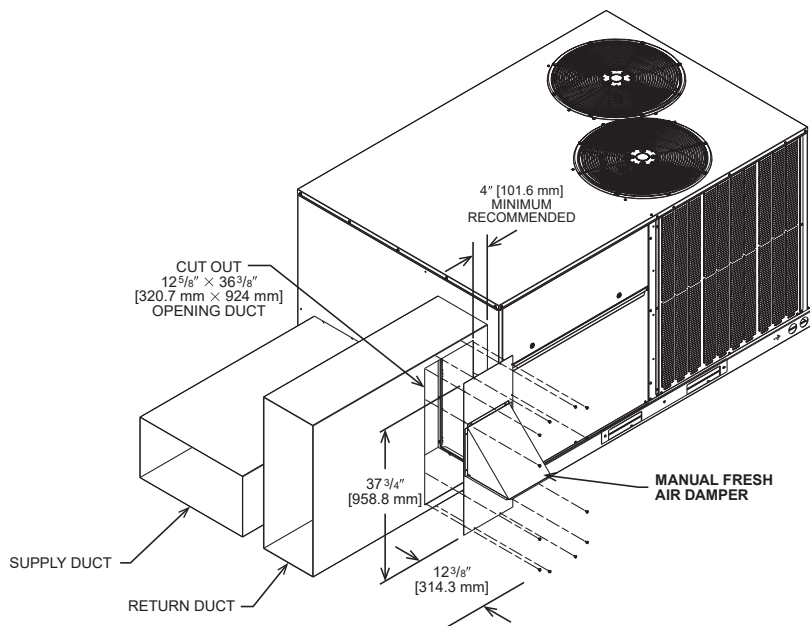

# Roof Curbs

**Table 21: Roof Curb Accessories**

Daikin Applied Model Number	Description
RXKG-DDD14	MPS-007D through MPS-012D

## Roof Curbs (Full Perimeter): 7 – 12 Tons [21.1 – 44.0 kW]

- One available height (14" [356 mm]) for all models
- 1" [25 mm] × 4" [102 mm] nailer provided
- Quick assembly corners for easy installation
- Insulating panels provided
- Opening provided in bottom pan to match the "Thru-the-Curb" electrical connection opening provided on the unit base pan
- Sealing gasket (28" [711 mm]) provided with roof curb
- 18 gauge galvanized steel

**Figure 54: Typical Roof Curb Installation: MPS 007D – 012D**

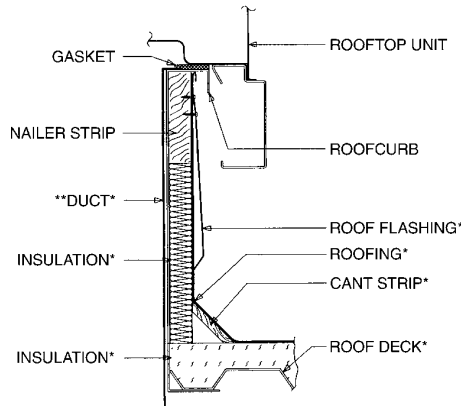

\*BY CONTRACTOR  
 \*\*FOR INSTALLATION OF DUCT AS SHOWN, USE RECOMMENDED DUCT SIZES FROM ROOFCURB INSTALLATION INSTRUCTIONS. FOR DUCT FLANGE ATTACHMENT TO UNIT, SEE UNIT INSTALLATION INSTRUCTIONS FOR RECOMMENDED DUCT SIZES.

### ROOFCURB INSTALLATION

[ ] Designates Metric Conversions

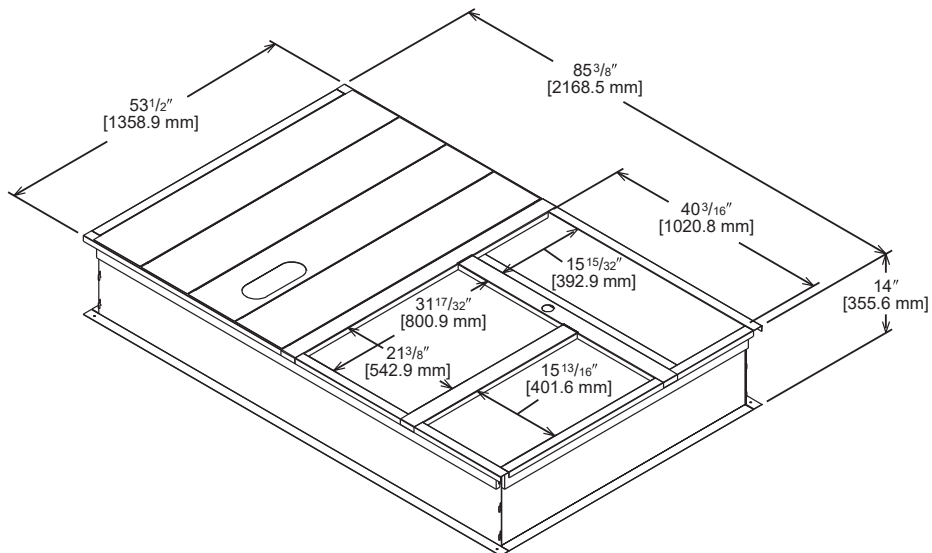

# Controls and Operation

## Furnace Section Controls and Ignition System

### Normal Furnace Operating Sequence

This unit is equipped with a two stage integrated direct spark ignition control.

#### Normal Heat Mode

##### Call For First Stage (Low Fire) Only:

1. Zone thermostat contacts close, a call for first stage (low fire) heat is initiated.
2. Control runs self check.
3. Control checks the high-limit switch for normally closed contacts, each pressure switch for normally open contacts, and all flame rollout switches for continuity.
4. Control energizes each low-fire inducer.
5. Control checks each low-fire pressure switch for closure.
6. If each low-fire pressure switch is closed, the control starts a 30 second prepurge. If either low-fire pressure switch is still open after 180 seconds, the high-fire inducers will be energized until closure.
7. After prepurge time-out, control initiates spark for two seconds minimum (seven second maximum) ignition trial, and initiates a 120 second – second stage (high fire) warm up timing.
8. Control detects flame, de-energizes spark and initiates 45 second delay on blower timing.
9. After a fixed 45 seconds indoor blower delay on, the control energizes the indoor blower.
10. After a fixed 120 seconds second stage warm-up period, control checks thermostat input. If only W1 is called for, W2 is de-energized and the control starts a 30 second OFF delay on the W2 inducer.
11. After fixed 30 seconds the W2 inducer is de-energized.
12. Control enters normal operating loop where all inputs are continuously checked.
13. Zone thermostat is satisfied.
14. Control de-energizes gas valve.
15. Control senses loss of flame.
16. Control initiates five second inducer postpurge and 90 second indoor blower delay off.
17. Control de-energizes inducer blower.
18. Control de-energizes indoor blower.
19. Control in the stand by mode with solid red LED.

##### Call For Second Stage, After First Stage Established; Starting from A.11:

1. If a call for second stage (high fire) is initiated after a call for first stage heat is established, the control energizes the W2 inducer and energizes the second stage of the gas valve.
2. Control enters normal operating loop where all inputs are continuously checked.

##### Second Stage Satisfied; First Stage Still Called For; Starting From B.3:

1. Once the call for second stage is satisfied, the control starts a 30 second OFF delay on W2 inducer and reduces the gas valve to first stage.
2. Control enters normal operating loop where all inputs are continuously checked.

##### First Stage Satisfied:

1. Zone thermostat is satisfied.
2. Control de-energizes gas valve.
3. Control senses loss of flame.
4. Control initiates five second inducer postpurge and 90 second indoor blower delay OFF.
5. Control de-energizes inducer blower.
6. Control de-energizes indoor blower.
7. Control in the stand by mode with solid red LED.

##### First Stage and Second Stage Called Simultaneously:

1. Zone thermostat contacts close, a call for first stage (low fire) and second stage (high fire) heat is initiated.
2. Control runs self check.
3. Control checks the high-limit switch for normally closed contacts, each pressure switch for normally open contacts, and all flame rollout switches for continuity.
4. Control energizes each low-fire inducer.
5. Control checks each pressure switch for closure.
6. If each low-fire pressure switch is closed, the control starts a 30 second prepurge. If either switch is still open after 180 seconds, the high-fire inducers will be energized until closure.
7. After prepurge time-out, control initiates spark for two seconds minimum (seven seconds maximum) ignition trial, and initiates a 120 second stage warm up timing.
8. Control detects flame, de-energizes spark and starts a 45 second indoor blower delay on timing.

9. After a fixed 45 seconds indoor blower delay on, the control energizes the indoor blower.
10. After a fixed 120 seconds second stage warm-up period, control checks the thermostat input. If W1 and W2 is present control enters normal operating loop where all inputs are continuously checked.

### First Stage and Second Stage Removed Simultaneously:

1. Upon a loss of W1 and W2 the gas valve is de-energized.
2. Upon a loss of flame, each inducer will complete a five second postpurge and the indoor blower will complete a 90 second delay OFF.
3. Control in the stand by mode with solid red LED.

The integrated control is a four-ignition system.

After a total of four cycles without sensing main burner flame, the system goes into a 100% lockout mode. After one hour, the ignition control repeats the prepurge and ignition cycles for 4 tries and then go into 100% lockout mode again. It continues this sequence of cycles and lockout each hour until ignition is successful or power is interrupted. During the lockout mode, neither the ignitor or gas valve will be energized until the system is reset by turning the thermostat to the "OFF" position or interrupting the electrical power to the unit for 3 seconds or longer. The induced draft blower and main burner will shut OFF when the thermostat is satisfied.

The circulating air blower will start and run on the heating speed if the thermostat fan switch is in the "ON" position. The integrated furnace control is equipped with diagnostic LED. The LED is lit continuously when there is power to the control, with or without a call for heat. If the LED is not lit, there is either no power to the control or there is an internal component failure within the control, and the control should be replaced.

If the control detects the following failures, the LED will flash on for approximately 1/4 second, then OFF for 3/4 second for designated failure detections.

1. Flash: Failed to detect flame within the four tries for ignition.
2. Flash: Pressure switch or induced draft blower problem detected.
3. Flash: High limit or auxiliary limit open.
4. Flash: Flame sensed and gas valve not energized or flame sensed with no "W" signal.
5. Flash: Over-temperature switch open.

## Operating Instructions

### DANGER

Never test for gas leaks with an open flame. It can cause an explosion or fire resulting in property damage, personal injury or death. Use a commercially available soap solution made specifically for the detection of leaks to check all connections as specified in the Mechanical Installation section of these instructions.

### DANGER

The spark ignitor and ignition leading from the ignition control are high voltage. Keep hands or tools away to prevent electrical shock. Shut off electrical power before servicing any of the controls. Failure to adhere to this warning can result in personal injury or death.

### DANGER

Should overheating occur or the gas supply fail to shut off, shut off the manual gas valve to the unit before shutting off the electrical supply. Failure to do so can result in an explosion or fire causing property damage, severe personal injury or death!

This unit is equipped with integrated furnace control. This device lights the main burners each time the room thermostat (closes) calls for heat. See operating instructions on the back of the furnace/controls access panel.

### To Start Furnace

1. Set the thermostat to its lowest setting.
2. Turn OFF all electric power to the unit.
3. This unit does not have a pilot. It is equipped with an ignition device which automatically lights the burner. Do not try to light the burner by hand.
4. Remove control door.
5. Move control knob to the "OFF" position. Turn the knob by hand only, do not use any kind of tool.
6. Wait five minutes to clear out any gas. Then smell for gas, including near the floor. If you smell gas, STOP! Follow B in the safety information on the Operating Instructions located on the back of the controls/access panel. If you don't smell gas, go to the next step.
7. Move the gas control knob from "OFF" position to "ON" position. Operate this unit with the gas control knob in the "ON" position only. Do not use the gas control knob as a means for throttling the burner input rate.
8. Replace the control door.
9. Turn ON all electric power to the unit.
10. Set the thermostat to the desired setting.
11. If the unit will not operate, follow the instructions below on how to shut down the furnace.

The initial start-up on a new installation may require the control system to be energized for some time until air has bled through the system and fuel gas is available at the burners.

### To Shut Down Furnace

1. Set the thermostat to the lowest setting.
2. Turn OFF all electric power to the unit if service is to be performed.
3. Remove control door.
4. Move control knob to the "OFF" position.
5. Replace control door.

### Burners

Burners for these units have been designed so that field adjustment is not required. Burners are tray-mounted and accessible for easy cleaning when required.

### Manual Reset Over-Temperature Control

#### **DANGER**

DO NOT JUMPER THIS DEVICE! DO NOT reset the over-temperature control without taking corrective action to assure that an adequate supply of combustion air is maintained under all conditions of operation. Failure to do so can result in carbon monoxide poisoning or death. Replace this control only with the identical replacement part.

Two manual reset over-temperature controls are located on the burner shield. These devices sense blockage in the heat exchanger or insufficient combustion air. This shuts off the main burners if excessive temperatures occur in the burner compartment.

Operation of this control indicates an abnormal condition. Therefore, the unit should be examined by a qualified installer, service agency, or the gas supplier before being placed back into operation.

### Pressure Switch

This furnace has two pressure switches for sensing a blocked exhaust or a failed induced draft blower. They are normally open and close when the induced draft blower starts, indicating air flow through the combustion chamber.

### Limit Control

#### **DANGER**

Do not jumper this device! Doing so can cause a fire or explosion resulting in property damage, personal injury or death.

#### **NOTICE**

Replace this control only with the identical replacement part.

The supply air high temperature limit cut-off is set at the factory and cannot be adjusted. It is calibrated to prevent the air temperature leaving the furnace from exceeding the maximum outlet air temperature.

# Maintenance

## General

### Advise The Customer

 **CAUTION**

Replace all blower doors and compartment cover after servicing the unit. Do not operate the unit without all panels and doors securely in place.

1. Change the air filters regularly. The heating system operates better, more efficiently and more economically.
2. Except for the mounting platform, keep all combustible articles three feet from the unit and exhaust system.
3. Do not allow snow or other debris to accumulate in the vicinity of the unit.

## Unit Maintenance

### Furnace Section

 **DANGER**

Label all wires prior to disconnection when servicing controls. wiring errors can cause improper and dangerous operation resulting in fire, electrical shock, property damage, personal injury or death.

 **DANGER**

Holes in the exhaust transition or heat exchanger can cause toxic fumes to enter the home. The exhaust transition or heat exchanger must be replaced if they have holes or cracks in them. Failure to do so can cause carbon monoxide poisoning resulting in personal injury or death.

 **DANGER**

Power supply to unit must be disconnected before making field connections. To avoid electrical shock, personal injury or death, be sure to rigorously adhere to field wiring procedures regarding proper lockout and tagout of components.

The unit's furnace should operate for many years without excessive scale build-up in flue passageways; however, it is recommended that a qualified installer, service agency, or the gas supplier annually inspect the flue passageways, the exhaust system and the burners for continued safe operation, paying particular attention to deterioration from corrosion or other sources.

If during inspection the flue passageways and exhaust system are determined to require cleaning, the following procedures should be followed (by a qualified installer, service agency, or gas supplier):

1. Turn OFF the electrical power to the unit and set the thermostat to the lowest temperature.
2. Shut OFF the gas supply to the unit either at the meter or at manual valve in the supply piping.
3. Remove the furnace controls access panel and the control box cover.
4. Disconnect the gas supply piping from the gas valve.
5. Disconnect the wiring to the induced draft blower motor, gas valve, flame sensor, and flame roll-out control, and ignitor cable. Mark all wires disconnected for proper reconnection.
6. Remove the screws (4) connecting the burner tray to the heat exchanger mounting panel.
7. Remove the burner tray and the manifold assembly from the unit.
8. Remove the screws (10) connecting the two induced draft blowers to the collector box and screws (12) connecting the inducer mounting plate to the heat exchanger center panel. Remove the induced draft blower and the collector box from the unit.
9. Remove the turbulators from inside the heat exchangers by inserting the blade of a screwdriver under the locking tabs. Pop the tabs out of the expanded grooves of the heat exchanger. Slide the turbulators out of the heat exchangers.
10. Direct a water hose into the outlet of the heat exchanger top. Flush the inside of each heat exchanger tube with water. Blow out each tube with air to remove excessive moisture.
11. Reassemble (steps 1 through 9 in reverse order). **Be careful not to strip out the screw holes used to mount the collector box and inducer blower. Replace inducer blower gasket and collector box gasket with factory replacements if damaged.**

The manufacturer recommends that a qualified installer, service agency or the gas supplier visually inspect the burner flames for the desired flame appearance at the beginning of the heating season and approximately midway in heating season.

The manufacturer also recommends that a qualified installer, service agency or the gas supplier clean the flame sensor with steel wool at the beginning of the heating season.

## Lubrication

### NOTICE

DO NOT attempt to lubricate the bearings on the blower motor or the induced draft blower motor. Addition of lubricants can reduce the motor life and void the warranty.

The blower motor and induced draft blower motor are pre-lubricated by the manufacturer and do not require further attention.

A qualified installer, service agency or the gas supplier must periodically clean the motors to prevent the possibility of overheating due to an accumulation of dust and dirt on the windings or on the motor exterior. And, as suggested elsewhere in these instructions, the air filters should be kept clean because dirty filters can restrict air flow and the motor depends upon sufficient air flowing across and through it to prevent overheating.

## Cooling Section

### DANGER

Power supply to unit must be disconnected before making field connections. To avoid electrical shock, personal injury or death, be sure to rigorously adhere to field wiring procedures regarding proper lockout and tagout of components.

### DANGER

Label all wires prior to disconnection when servicing the unit. Wiring errors can cause improper and dangerous operation resulting in fire, electrical shock, property damage, severe personal injury or death.

It is recommended that at the beginning of each cooling season a qualified installer or service agency inspect and clean the cooling section of this unit. The following areas should be addressed: evaporator coil, condenser coil, condenser fan motor and venturi area.

## To Inspect The Evaporator Coil

1. Open the control/filter access panel and remove filters. Also, remove blower access panel. In downflow applications remove the horizontal return to gain access.
2. Shine a flashlight on the evaporator coil (both sides) and inspect for accumulation of lint, insulation, etc.
3. If coil requires cleaning, follow the steps shown.

## Cleaning Evaporator Coil

### CAUTION

Do not use excessive water pressure. Excessive water pressure can bend the fins and tubing of the coil and lead to inadequate unit performance. Be careful not to splash water excessively into unit.

1. The coil should be cleaned when it is dry. If the coil is coated with dirt or lint, vacuum it with a soft brush attachment. Be careful not to bend the coil fins.
2. If the coil is coated with oil or grease, clean it with a mild detergent-and-water solution. Rinse the coil thoroughly with water.
3. Inspect the drain pan and condensate drain at the same time the evaporator coil is checked. Clean the drain pan by flushing with water and removing any matters of obstructions which may be present.
4. Go to next section for cleaning the condenser coil.

## Cleaning Condenser Coil, Condenser Fan, Circulation Air Blower and Venturi

### CAUTION

Do not use excessive water pressure. Excessive water pressure can bend the fins and tubing of the coil and lead to inadequate unit performance. Be careful not to splash water excessively into unit.

1. Remove the compressor access panel. Disconnect the wires to the condenser fan motor in the control box (see wiring diagram).
2. The coil should be cleaned when it is dry. If the coil is coated with dirt or lint, vacuum it with a soft brush attachment. Be careful not to bend the coil fins.
3. If the coil is coated with oil or grease, clean it with a mild detergent-and-water solution. Rinse the coil thoroughly with water.
4. The venturi should also be inspected for items of obstruction such as collections of grass, dirt or spider webs. Remove any that are present.
5. Inspect the circulating air blower wheel and motor for accumulation of lint, dirt or other obstruction and clean it necessary. Inspect the blower motor mounts and the blower housing for loose mounts or other damage. Repair or replace if necessary.

## Re-Assembly

1. Reconnect fan motor wires per the wiring diagram attached to the back of the cover.
2. Close the filter control and replace the blower/evaporator coil access panels.
3. Replace the control box cover.
4. Restore electrical power to the unit and check for proper operation, especially the condenser fan motor.

# System Charging Charts

Figure 55: System Charging Charts — 7.5 Ton Two-Stage AC

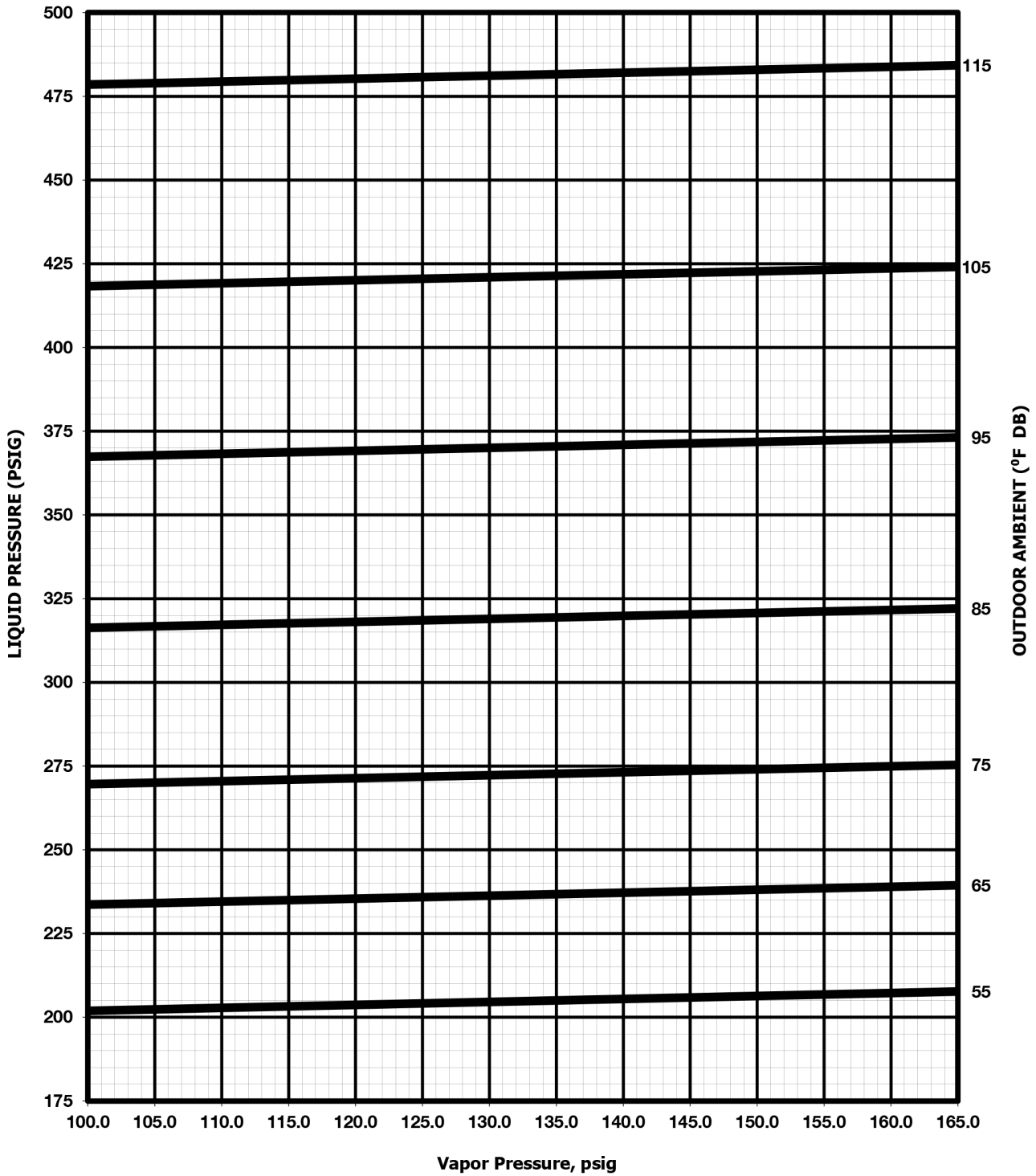

- CAUTION: 1. RETURN AIR TEMPERATURE MUST BE WITHIN COMFORT CONDITIONS BEFORE FINAL REFRIGERANT CHECK!**
- INSTRUCTIONS:**
1. MEASURE PRESSURE AT COMPRESSOR SUCTION AND LIQUID.
  2. MEASURE OUTDOOR AMBIENT TO UNIT.
  3. PLACE X ON CHART WHERE SUCTION AND LIQUID INTERSECT.
  4. IF X IS BELOW OUTDOOR AMBIENT LINE, ADD CHARGE AND REPEAT STEPS 1-3.
  5. IF X IS ABOVE OUTDOOR AMBIENT LINE, RECOVER EXCESS CHARGE AND REPEAT STEPS 1-3.

Figure 56: System Charging Charts — 8.5 Ton Two-Stage AC

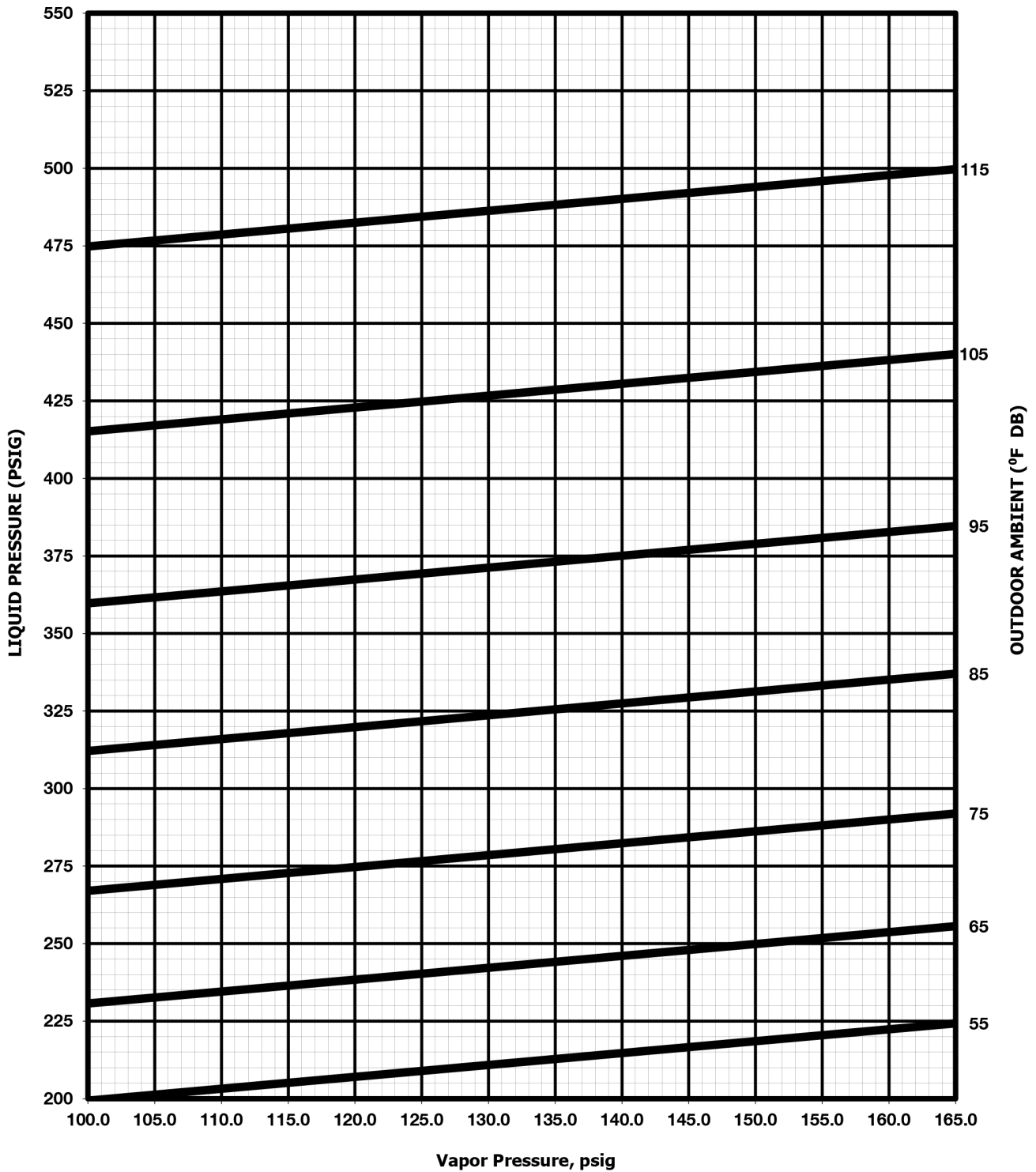

- CAUTION: 1. RETURN AIR TEMPERATURE MUST BE WITHIN COMFORT CONDITIONS BEFORE FINAL REFRIGERANT CHECK!**
- INSTRUCTIONS:**
1. MEASURE PRESSURE AT COMPRESSOR SUCTION AND LIQUID.
  2. MEASURE OUTDOOR AMBIENT TO UNIT.
  3. PLACE X ON CHART WHERE SUCTION AND LIQUID INTERSECT.
  4. IF X IS BELOW OUTDOOR AMBIENT LINE, ADD CHARGE AND REPEAT STEPS 1-3.
  5. IF X IS ABOVE OUTDOOR AMBIENT LINE, RECOVER EXCESS CHARGE AND REPEAT STEPS 1-3.

Figure 57: System Charging Charts — 10 Ton Two-Stage AC

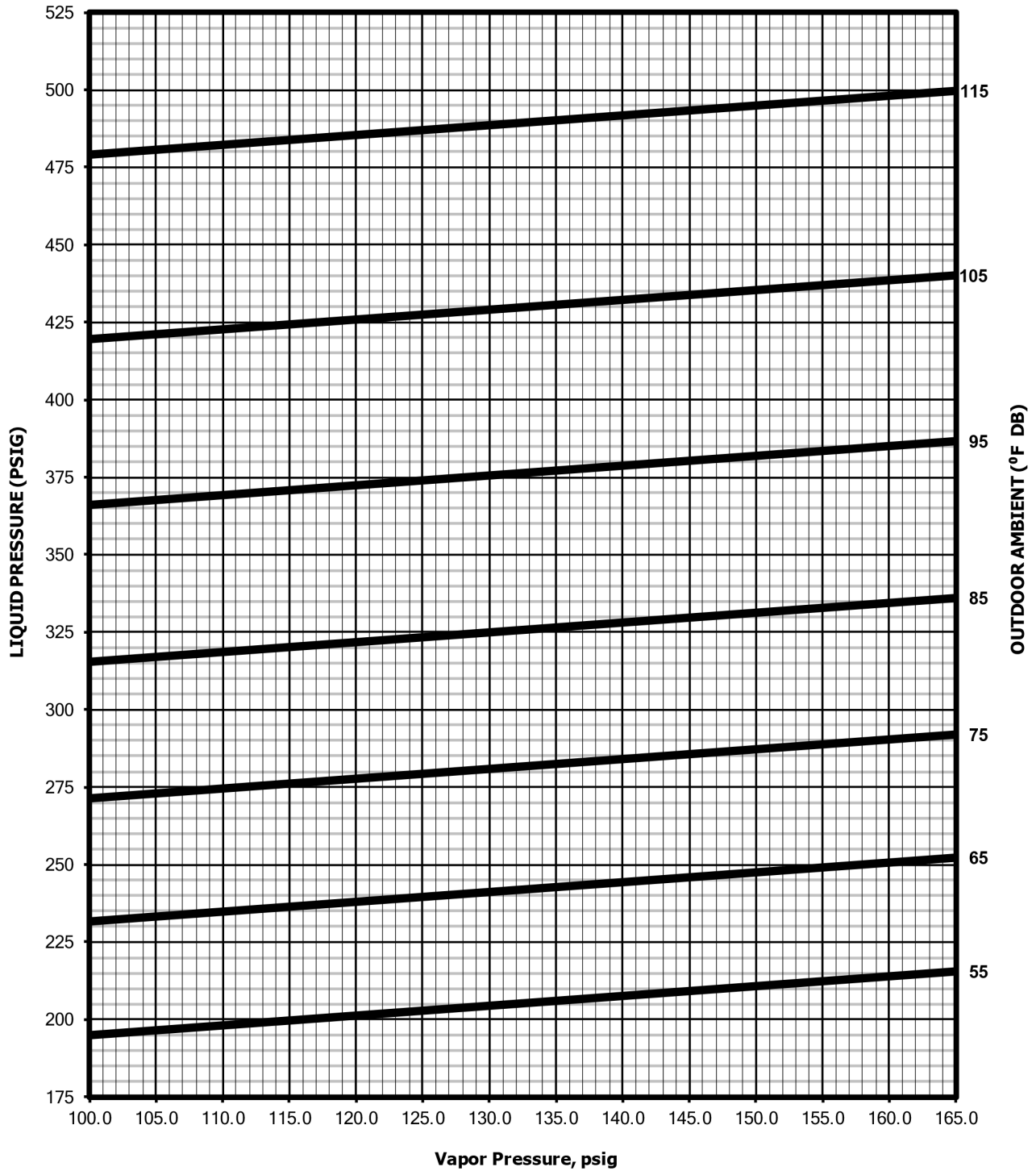

- CAUTION:** 1. RETURN AIR TEMPERATURE MUST BE WITHIN COMFORT CONDITIONS BEFORE FINAL REFRIGERANT CHECK!
- INSTRUCTIONS:**
1. MEASURE PRESSURE AT COMPRESSOR SUCTION AND LIQUID.
  2. MEASURE OUTDOOR AMBIENT TO UNIT.
  3. PLACE X ON CHART WHERE SUCTION AND LIQUID INTERSECT.
  4. IF X IS BELOW OUTDOOR AMBIENT LINE, ADD CHARGE AND REPEAT STEPS 1-3.
  5. IF X IS ABOVE OUTDOOR AMBIENT LINE, RECOVER EXCESS CHARGE AND REPEAT STEPS 1-3.

Figure 58: System Charging Charts — 12.5 Ton AC

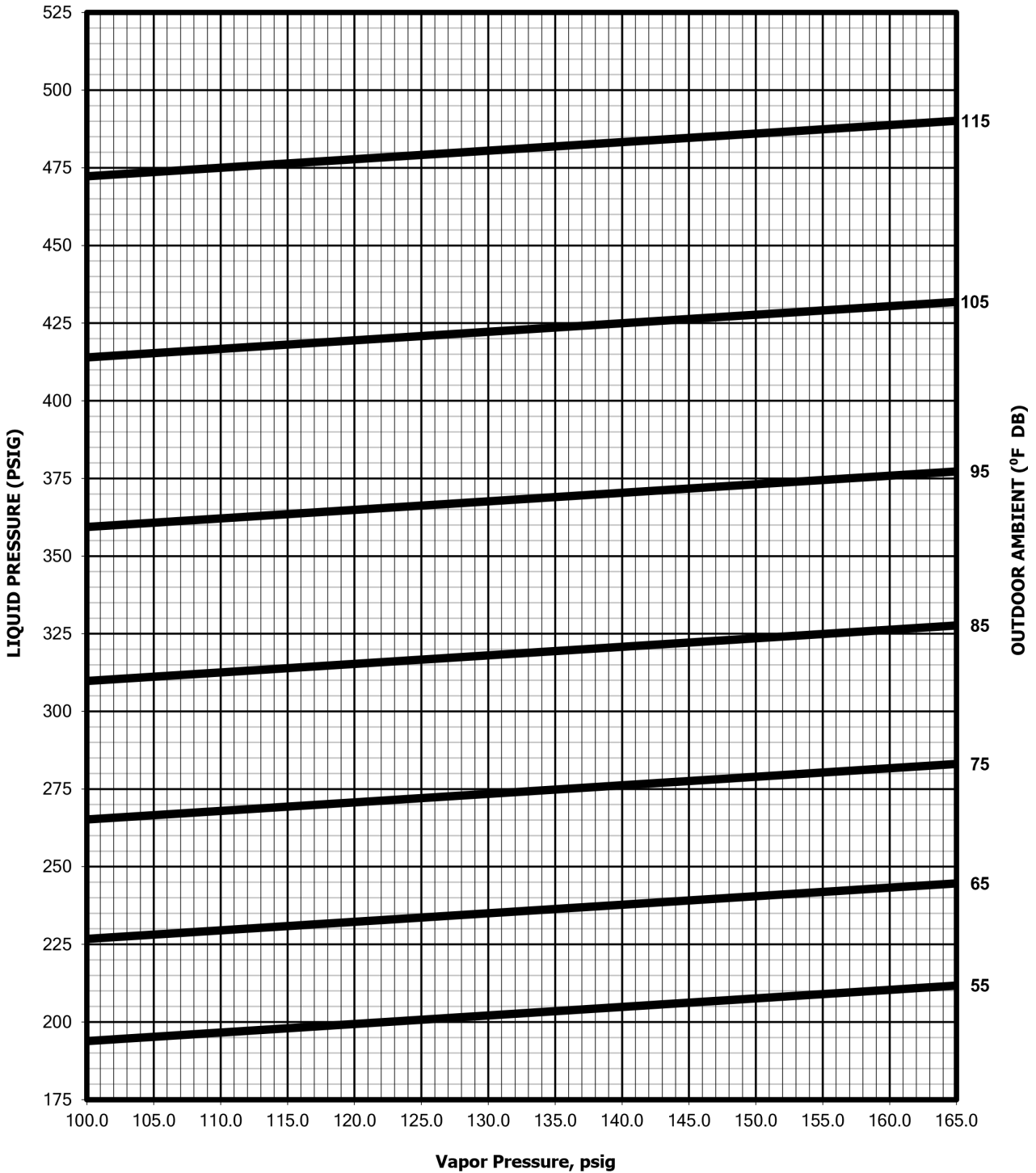

- CAUTION:** 1. RETURN AIR TEMPERATURE MUST BE WITHIN COMFORT CONDITIONS BEFORE FINAL REFRIGERANT CHECK!
- INSTRUCTIONS:**
1. MEASURE PRESSURE AT COMPRESSOR SUCTION AND LIQUID.
  2. MEASURE OUTDOOR AMBIENT TO UNIT.
  3. PLACE X ON CHART WHERE SUCTION AND LIQUID INTERSECT.
  4. IF X IS BELOW OUTDOOR AMBIENT LINE, ADD CHARGE AND REPEAT STEPS 1-3.
  5. IF X IS ABOVE OUTDOOR AMBIENT LINE, RECOVER EXCESS CHARGE AND REPEAT STEPS 1-3.

Figure 59: System Charging Charts — 7.5 Tons Two-Stage with Reheat

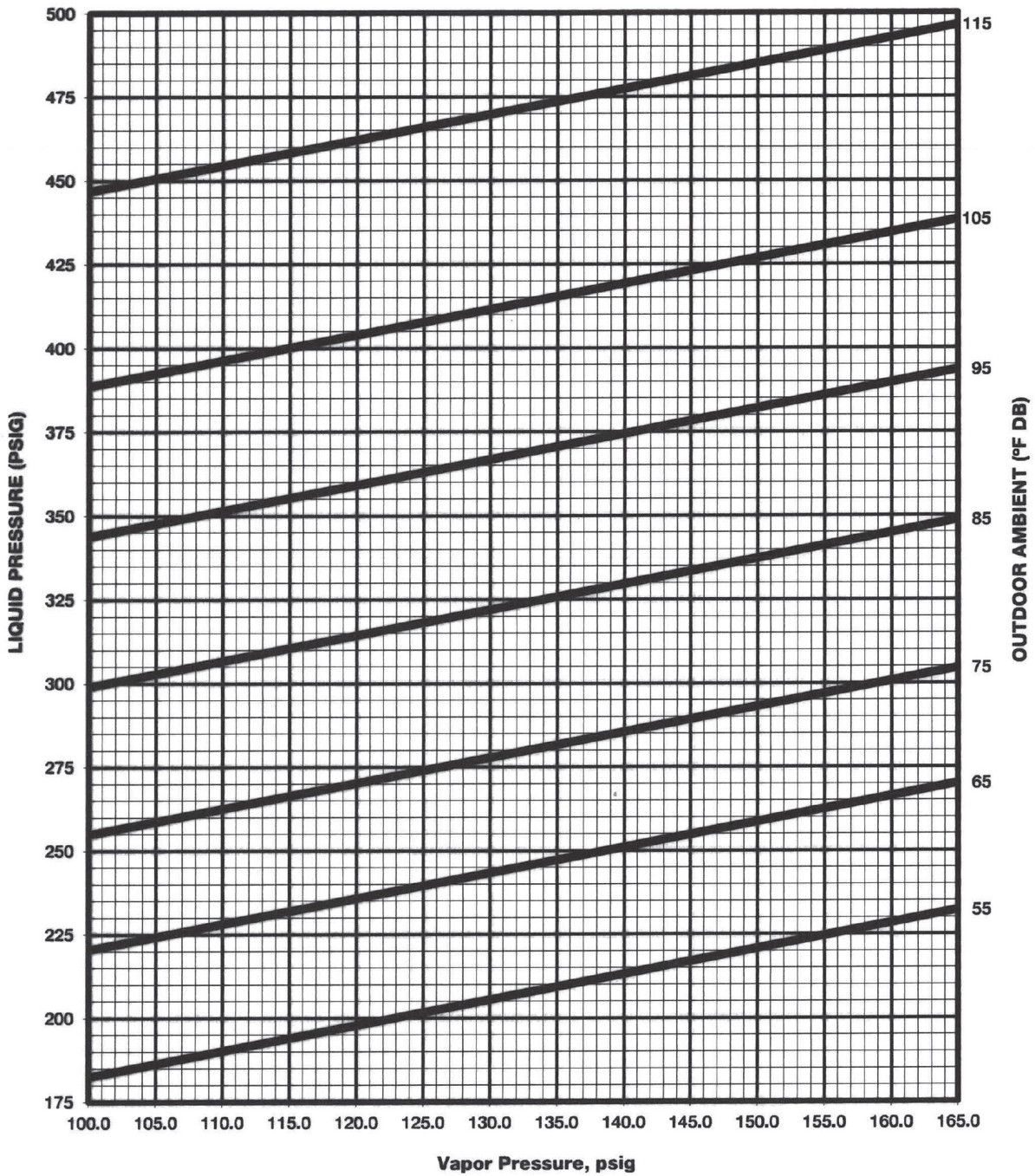

**CAUTION: 1. RETURN AIR TEMPERATURE MUST BE WITHIN COMFORT CONDITIONS BEFORE FINAL REFRIGERANT CHECK!**  
**INSTRUCTIONS: 1. MEASURE PRESSURE AT COMPRESSOR SUCTION AND LIQUID.**  
**2. MEASURE OUTDOOR AMBIENT TO UNIT.**  
**3. PLACE X ON CHART WHERE SUCTION AND LIQUID INTERSECT.**  
**4. IF X IS BELOW OUTDOOR AMBIENT LINE, ADD CHARGE AND REPEAT STEPS 1-3.**  
**5. IF X IS ABOVE OUTDOOR AMBIENT LINE, RECOVER EXCESS CHARGE AND REPEAT STEPS 1-3.**

Figure 60: System Charging Charts — 8.5 Tons Two-Stage with Reheat

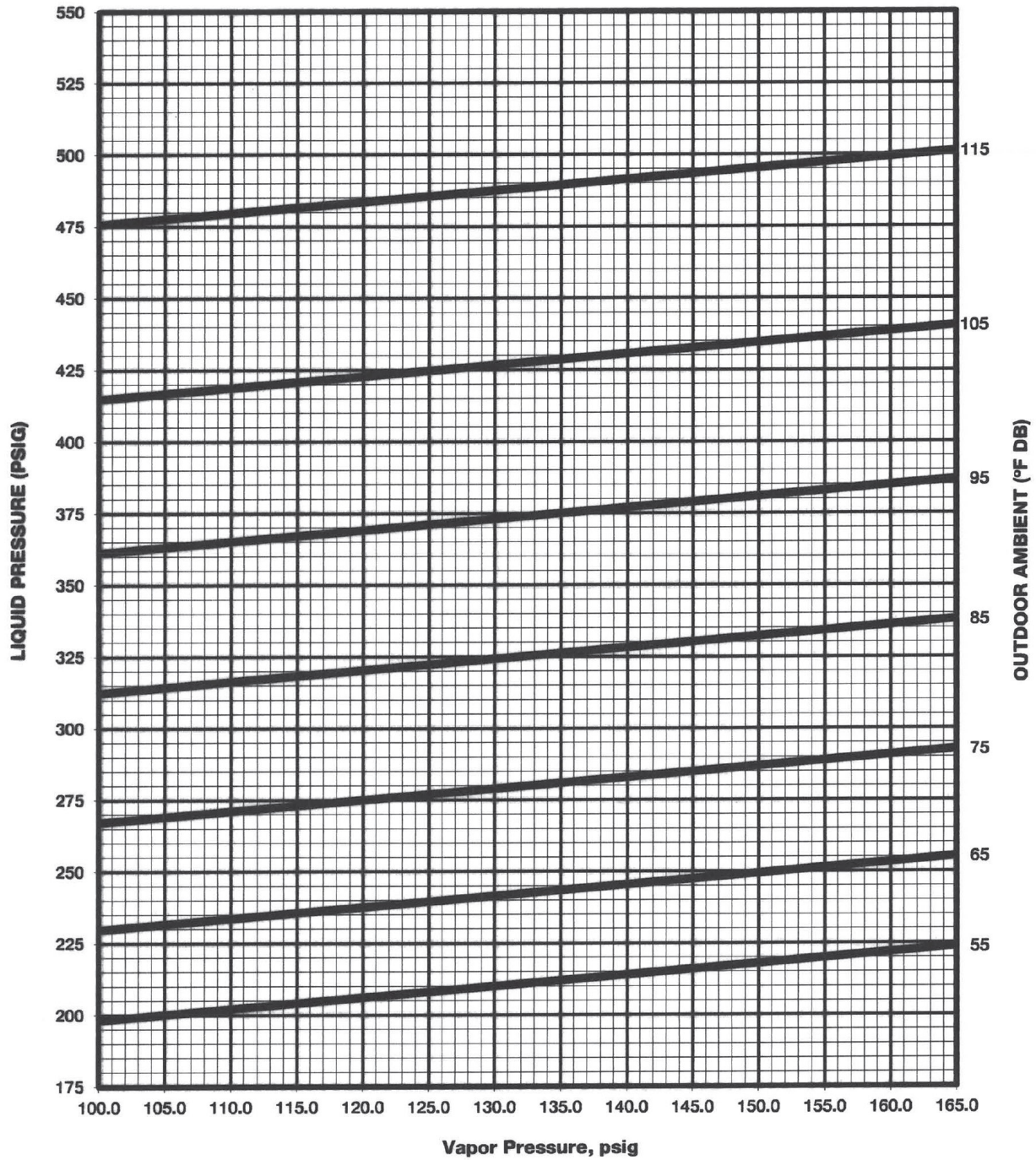

**CAUTION: 1. RETURN AIR TEMPERATURE MUST BE WITHIN COMFORT CONDITIONS BEFORE FINAL REFRIGERANT CHECK!**  
**INSTRUCTIONS: 1. MEASURE PRESSURE AT COMPRESSOR SUCTION AND LIQUID.**  
**2. MEASURE OUTDOOR AMBIENT TO UNIT.**  
**3. PLACE X ON CHART WHERE SUCTION AND LIQUID INTERSECT.**  
**4. IF X IS BELOW OUTDOOR AMBIENT LINE, ADD CHARGE AND REPEAT STEPS 1-3.**  
**5. IF X IS ABOVE OUTDOOR AMBIENT LINE, RECOVER EXCESS CHARGE AND REPEAT STEPS 1-3.**

Figure 61: System Charging Charts — 10.0 Tons Two-Stage with Reheat

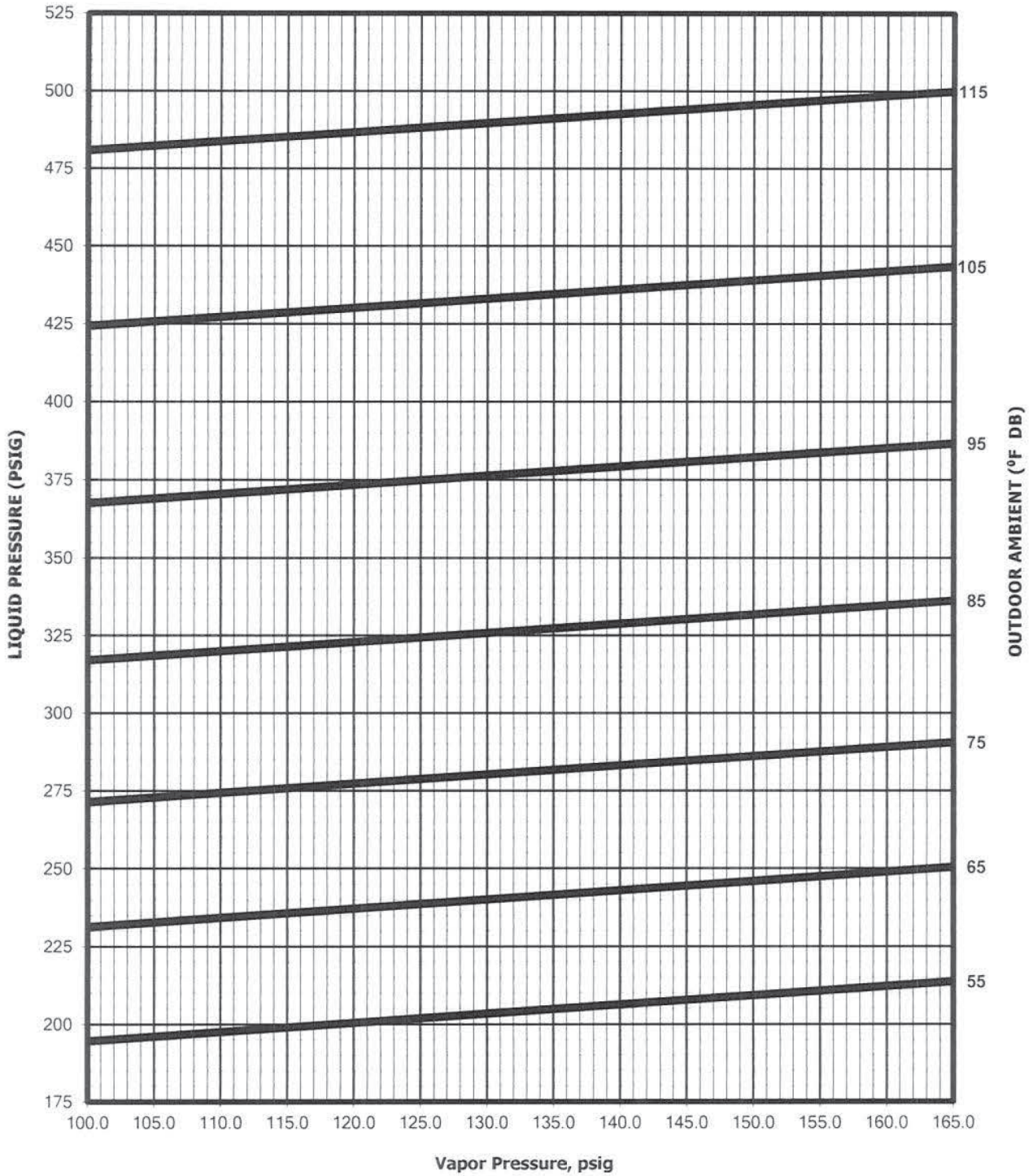

- CAUTION:** 1. RETURN AIR TEMPERATURE MUST BE WITHIN COMFORT CONDITIONS BEFORE FINAL REFRIGERANT CHECK!
- INSTRUCTIONS:** 1. MEASURE PRESSURE AT COMPRESSOR SUCTION AND LIQUID.  
 2. MEASURE OUTDOOR AMBIENT TO UNIT.  
 3. PLACE X ON CHART WHERE SUCTION AND LIQUID INTERSECT.  
 4. IF X IS BELOW OUTDOOR AMBIENT LINE, ADD CHARGE AND REPEAT STEPS 1-3.  
 5. IF X IS ABOVE OUTDOOR AMBIENT LINE, RECOVER EXCESS CHARGE AND REPEAT STEPS 1-3.

Figure 62: System Charging Charts — 12.5 Tons Two-Stage with Reheat

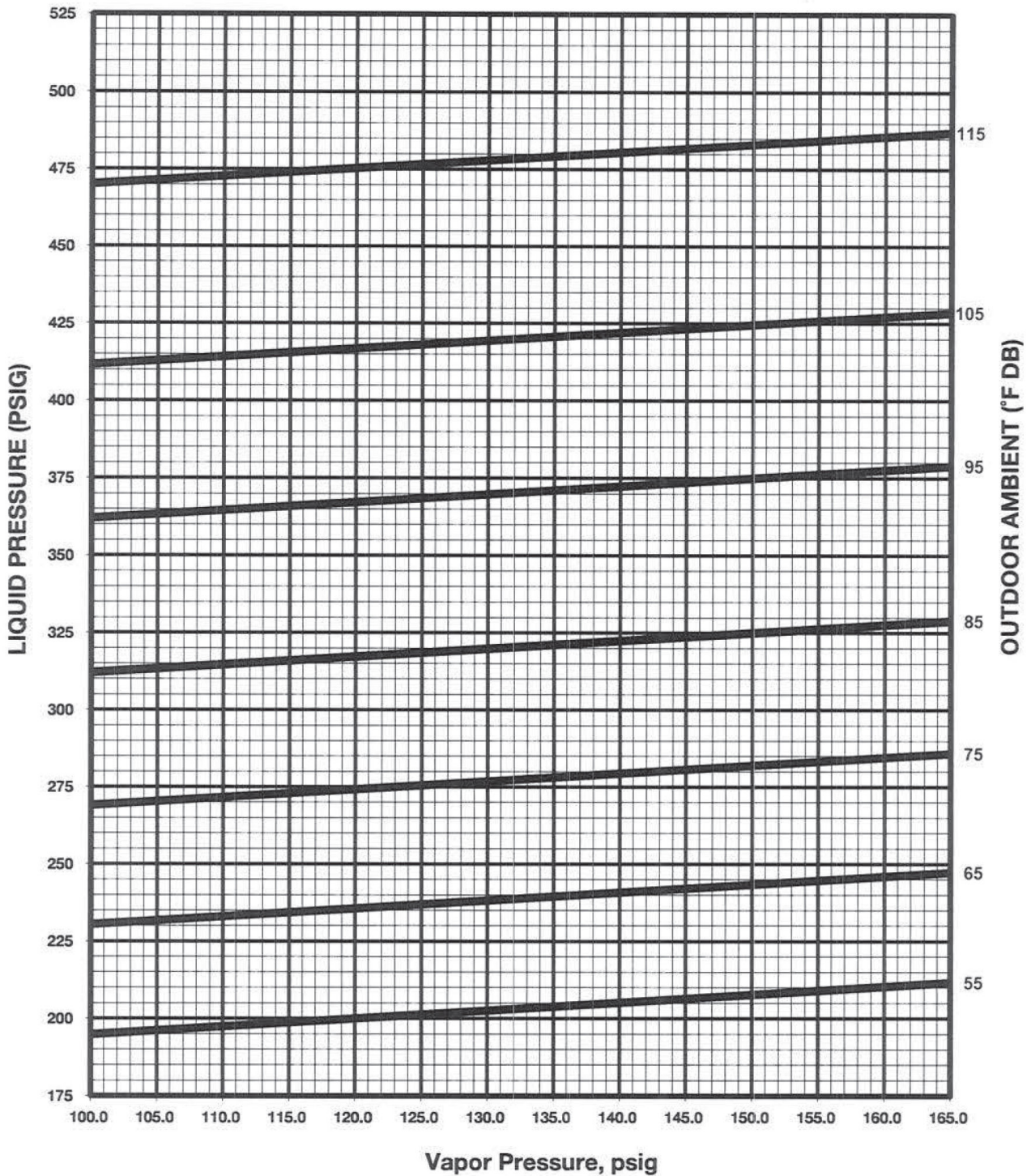

- CAUTION:** 1. RETURN AIR TEMPERATURE MUST BE WITHIN COMFORT CONDITIONS BEFORE FINAL REFRIGERANT CHECK!
- INSTRUCTIONS:** 1. MEASURE PRESSURE AT COMPRESSOR SUCTION AND L LIQUID.  
 2. MEASURE OUTDOOR AMBIENT TO UNIT.  
 3. PLACE X ON CHART WHERE SUCTION AND LIQUID INTERSECT.  
 4. IF X IS BELOW OUTDOOR AMBIENT LINE, ADD CHARGE AND REPEAT STEPS 1-3.  
 5. IF X IS ABOVE OUTDOOR AMBIENT LINE, RECOVER EXCESS CHARGE AND REPEAT STEPS 1-3.

# Troubleshooting

## Cooling Troubleshooting Chart

### DANGER

Disconnect all power to unit before servicing. Contactor may break only one side. Failure to shut off power can cause electrical shock resulting in personal injury or death.

SYMPTOM	POSSIBLE CAUSE	REMEDY
Unit will not run	<ul style="list-style-type: none"> <li>Power off or loose electrical connection</li> <li>Thermostat out of calibration-set too high</li> <li>Failed contactor</li> <li>Blown fuses</li> <li>Transformer defective</li> <li>High pressure control open (if provided)</li> <li>Interconnecting low voltage wiring damaged</li> </ul>	<ul style="list-style-type: none"> <li>Check for correct voltage at compressor contactor in control box</li> <li>Reset</li> <li>Check for 24 volts at contactor coil replace if contacts are open</li> <li>Replace fuses</li> <li>Check wiring-replace transformer</li> <li>Reset-also see high head pressure remedy – The high pressure control opens at 450 PSIG</li> <li>Replace thermostat wiring</li> </ul>
Condenser fan runs, compressor doesn't	<ul style="list-style-type: none"> <li>Loose connection</li> <li>Compressor stuck, grounded or open motor winding, open internal overload.</li> <li>Low voltage condition</li> </ul>	<ul style="list-style-type: none"> <li>Check for correct voltage at compressor check &amp; tighten all connections</li> <li>Wait at least 2 hours for overload to reset. If still open, replace the compressor.</li> <li>At compressor terminals, voltage must be within 10% of rating plate volts when unit is operating</li> <li>Add start kit components</li> </ul>
Insufficient cooling	<ul style="list-style-type: none"> <li>Improperly sized unit</li> <li>Improper airflow</li> <li>Incorrect refrigerant charge</li> <li>Air, non-condensable or moisture in system</li> <li>Incorrect voltage</li> </ul>	<ul style="list-style-type: none"> <li>Recalculate load</li> <li>Check should be approximately 400 CFM per ton.</li> <li>Charge per procedure attached to unit service panel</li> <li>Recover refrigerant, evacuate &amp; recharge, add filter drier</li> <li>At compressor terminals, voltage must be within 10% of rating plate volts when unit is operating.</li> </ul>
Compressor short cycles	<ul style="list-style-type: none"> <li>Incorrect voltage</li> <li>Defective overload protector</li> <li>Refrigerant undercharge</li> </ul>	<ul style="list-style-type: none"> <li>At compressor terminals, voltage must be <math>\pm 10\%</math> of nameplate marking when unit is operating.</li> <li>Replace check for correct voltage</li> <li>Add refrigerant</li> </ul>
Registers sweat	<ul style="list-style-type: none"> <li>Low evaporator airflow</li> </ul>	<ul style="list-style-type: none"> <li>Increase speed of blower or reduce restriction replace air filter</li> </ul>
High head-low vapor pressures	<ul style="list-style-type: none"> <li>Restriction in liquid line, expansion device or filter drier</li> <li>Flow check piston size too small</li> <li>Incorrect capillary tubes</li> </ul>	<ul style="list-style-type: none"> <li>Remove or replace defective component</li> <li>Change to correct size piston</li> <li>Change coil assembly</li> </ul>
High head-high or normal vapor pressure Cooling mode	<ul style="list-style-type: none"> <li>Dirty condenser coil</li> <li>Refrigerant overcharge</li> <li>Condenser fan not running</li> <li>Air or non-condensable in system</li> </ul>	<ul style="list-style-type: none"> <li>Clean coil</li> <li>Correct system charge</li> <li>Repair or replace</li> <li>Recover refrigerant, evacuate &amp; recharge</li> </ul>
Low vapor – cool compressor iced evaporator coil	<ul style="list-style-type: none"> <li>Defective Compressor valves</li> <li>Incorrect capillary tubes</li> </ul>	<ul style="list-style-type: none"> <li>Replace compressor</li> <li>Replace coil assembly</li> </ul>
Low vapor cool evaporator coil	<ul style="list-style-type: none"> <li>Low evaporator airflow</li> <li>Operating below 65°F outdoors</li> <li>Moisture in system</li> </ul>	<ul style="list-style-type: none"> <li>Increase speed of blower or reduce restriction replace air filter</li> <li>Add Low Ambient Kit</li> <li>Recover refrigerant evacuate &amp; recharge add filter drier</li> </ul>
High vapor pressure	<ul style="list-style-type: none"> <li>Excessive load</li> <li>Defective compressor</li> </ul>	<ul style="list-style-type: none"> <li>Recheck load calculation</li> <li>Replace</li> </ul>
Fluctuating head & vapor	<ul style="list-style-type: none"> <li>Air or non-condensate in system</li> </ul>	<ul style="list-style-type: none"> <li>Recover refrigerant, evacuate &amp; recharge</li> </ul>
Gurgle or pulsing noise at expansion device or liquid line	<ul style="list-style-type: none"> <li>Air or non-condensable in system</li> </ul>	<ul style="list-style-type: none"> <li>Recover refrigerant, evacuate &amp; recharge</li> </ul>

# Furnace Troubleshooting Guide

**WARNING**

**HAZARDOUS VOLTAGE**  
LINE VOLTAGE  
CONNECTIONS

**DISCONNECT POWER BEFORE**  
SERVICING.  
SERVICE MUST BE BY A TRAINED,  
QUALIFIED SERVICE TECHNICIAN.

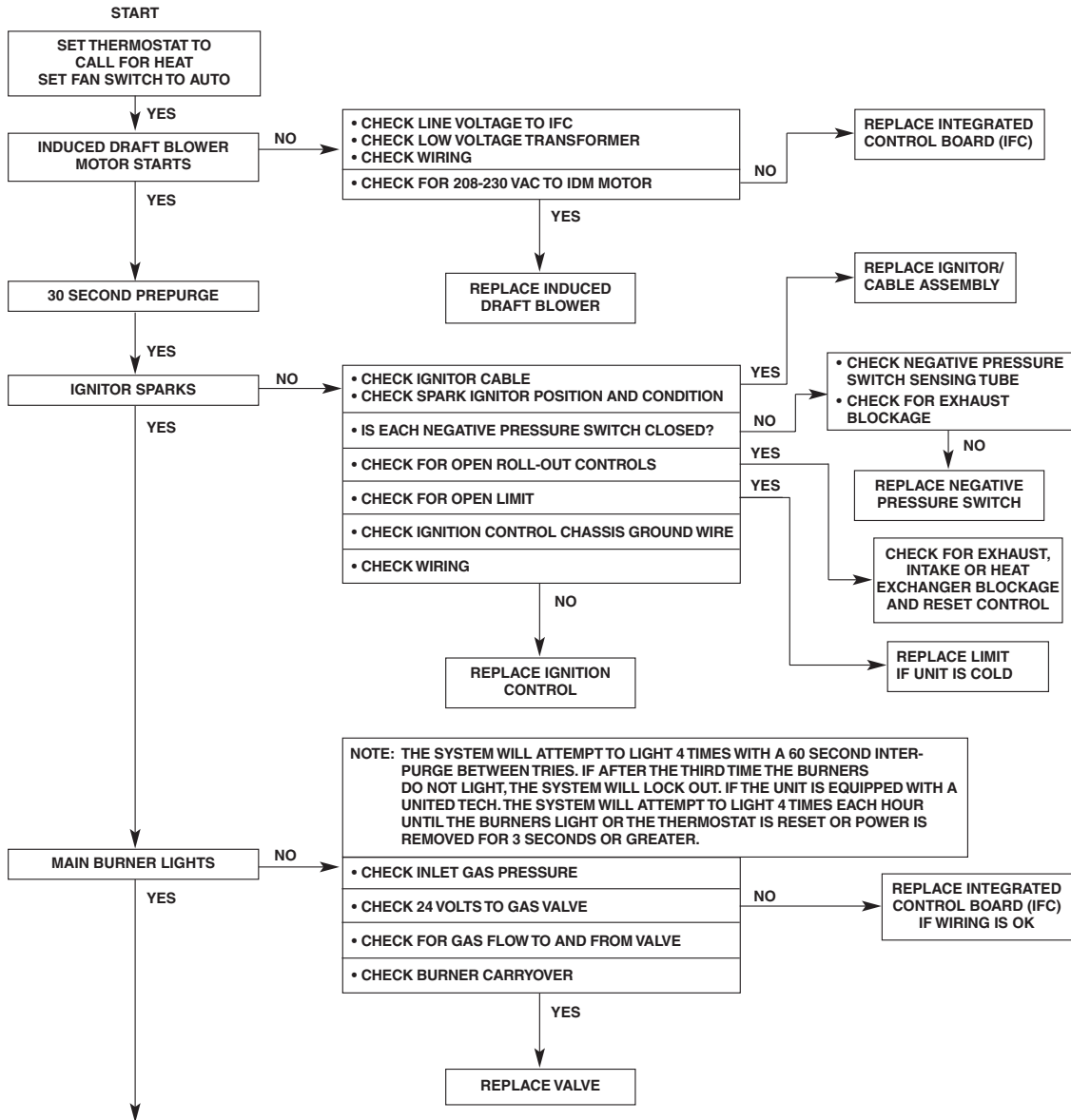

FLOW CHART CONTINUED ON NEXT PAGE

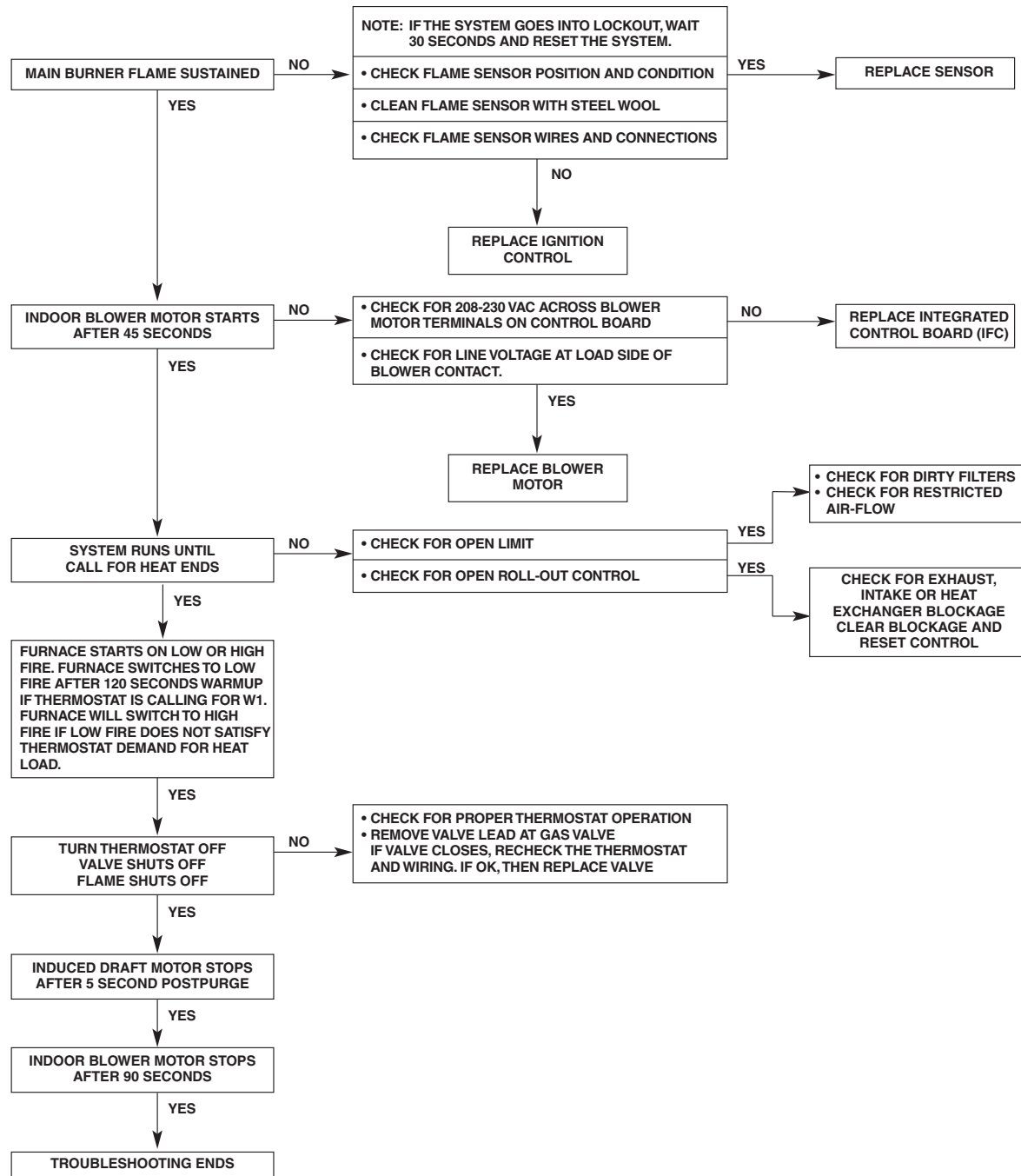

REPEAT PROCEDURE UNTIL TROUBLE FREE OPERATION IS OBTAINED.

# Warranty

## Limited Product Warranty



DAIKIN APPLIED AMERICAS INC.  
LIMITED PRODUCT WARRANTY  
(United States and Canada)

### WARRANTY

Daikin Applied Americas Inc. dba Daikin Applied ("Company") warrants to contractor, purchaser and any owner of the product (collectively "Owner") that, subject to the exclusions set forth below Company, at its option, will repair or replace defective parts in the event any product manufactured by Company, including products sold under the brand name Daikin and used in the United States or Canada, proves defective in material or workmanship within twelve (12) months from initial startup or eighteen (18) months from the date shipped by Company, whichever occurs first. Authorized replacement parts are warranted for the remainder of the original warranty. All shipments of such parts will be made FOB factory, freight prepaid and allowed. Company reserves the right to select carrier and method of shipment. In addition, Company provides labor to repair or replace warranty parts during Company normal working hours on products with rotary screw compressors or centrifugal compressors. Warranty labor is not provided for any other products.

Company must receive the Registration and Startup Forms for products containing motor compressors and/or furnaces within ten (10) days of original product startup, or the ship date and the startup date will be deemed the same for determining the commencement of the warranty period and this warranty shall expire twelve (12) months from that date. For additional consideration, Company will provide an extended warranty(ies) on certain products or components thereof. The terms of the extended warranty(ies) are shown on a separate extended warranty statement.

No person (including any agent, sales representative, dealer or distributor) has the authority to expand the Company's obligation beyond the terms of this express warranty or to state that the performance of the product is other than that published by Company.

### EXCLUSIONS

1. If free warranty labor is available as set forth above, such free labor does not include diagnostic visits, inspections, travel time and related expenses, or unusual access time or costs required by product location.
2. Refrigerants, fluids, oils and expendable items such as filters are not covered by this warranty.
3. This warranty shall not apply to products or parts: (a) that have been opened, disassembled, repaired, or altered, in each case by anyone other than Company or its authorized service representative; (b) that have been subjected to misuse, abuse, negligence, accidents, damage, or abnormal use or service; (c) that have not been properly maintained; (d) that have been operated or installed, or have had startup performed, in each case in a manner contrary to Company's printed instructions; (e) that have been exposed, directly or indirectly, to a corrosive atmosphere or material such as, but not limited to, chlorine, fluorine, fertilizers, waste water, urine, rust, salt, sulfur, ozone, or other chemicals, contaminants, minerals, or corrosive agents; (f) that were manufactured or furnished by others and/or are not an integral part of a product manufactured by Company; or (g) for which Company has not been paid in full.
4. This warranty shall not apply to products with rotary screw compressors or centrifugal compressors if such products have not been started, or if such startup has not been performed, by a Daikin Applied or Company authorized service representative.

### SOLE REMEDY AND LIMITATION OF LIABILITY

THIS WARRANTY CONSTITUTES THE SOLE WARRANTY MADE BY COMPANY. COMPANY'S LIABILITY TO OWNER AND OWNER'S SOLE REMEDY UNDER THIS WARRANTY SHALL NOT EXCEED THE LESSER OF: (i) THE COST OF REPAIRING OR REPLACING DEFECTIVE PRODUCTS; AND (ii) THE ORIGINAL PURCHASE PRICE ACTUALLY PAID FOR THE PRODUCTS. COMPANY MAKES NO REPRESENTATION OR WARRANTY, EXPRESS OR IMPLIED, REGARDING PREVENTION OF MOLD/MOULD, FUNGUS, BACTERIA, MICROBIAL GROWTH, OR ANY OTHER CONTAMINATES. THIS WARRANTY IS GIVEN IN LIEU OF ALL OTHER WARRANTIES, INCLUDING, WITHOUT LIMITATION, THE IMPLIED WARRANTIES OF MERCHANTABILITY, FITNESS FOR A PARTICULAR PURPOSE, AND NON-INFRINGEMENT, WHICH ARE HEREBY DISCLAIMED. IN NO EVENT AND UNDER NO CIRCUMSTANCE SHALL COMPANY BE LIABLE TO OWNER OR ANY THIRD PARTY FOR INCIDENTAL, INDIRECT, SPECIAL, CONTINGENT, CONSEQUENTIAL, DELAY OR LIQUIDATED DAMAGES FOR ANY REASON, ARISING FROM ANY CAUSE WHATSOEVER, WHETHER THE THEORY FOR RECOVERY IS BASED IN LAW OR IN EQUITY, OR IS UNDER A THEORY OF BREACH CONTRACT OR WARRANTY, NEGLIGENCE, STRICT LIABILITY, OR OTHERWISE. THE TERM "CONSEQUENTIAL DAMAGE" INCLUDES, WITHOUT LIMITATION, THOSE DAMAGES ARISING FROM BUSINESS INTERRUPTION OR ECONOMIC LOSS, SUCH AS LOSS OF ANTICIPATED PROFITS, REVENUE, PRODUCTION, USE, REPUTATION, DATA OR CROPS.

### ASSISTANCE

To obtain assistance or information regarding this warranty, please contact your local sales representative or a Daikin Applied office.

Form No. 933-430285Y-01-A (11/2023)  
Part No. 043028500 Rev.0F

## Replacement Parts

To find your local Daikin Applied Certified Parts Distributor, go to [www.DaikinApplied.com](http://www.DaikinApplied.com) and select Parts Locator.

# Rooftop Warranty Registration Form



## Rooftop Equipment Warranty Registration Form

To comply with the terms of Daikin Applied Warranty, complete and return this form within 10 days to the Warranty Department of Daikin Applied.

Check, test, and start procedure for Rooftop roof mounted air conditioners with or without heat recovery and roof mounted air handlers.

### GENERAL INFORMATION

Job Name: \_\_\_\_\_ Unit No.: \_\_\_\_\_

SOI No.: \_\_\_\_\_

Installation address: \_\_\_\_\_

City: \_\_\_\_\_ State: \_\_\_\_\_

Purchasing contractor: \_\_\_\_\_

City: \_\_\_\_\_ State: \_\_\_\_\_

Name of person doing start-up: \_\_\_\_\_

Company name: \_\_\_\_\_

Address: \_\_\_\_\_

City/State/Zip: \_\_\_\_\_

### UNIT INFORMATION

Unit model number: \_\_\_\_\_ Unit serial number: \_\_\_\_\_

Compressor 1 model number: \_\_\_\_\_ Serial number: \_\_\_\_\_

Compressor 2 model number: \_\_\_\_\_ Serial number: \_\_\_\_\_

Compressor 3 model number: \_\_\_\_\_ Serial number: \_\_\_\_\_

Compressor 4 model number: \_\_\_\_\_ Serial number: \_\_\_\_\_

Compressor 5 model number: \_\_\_\_\_ Serial number: \_\_\_\_\_

Compressor 6 model number: \_\_\_\_\_ Serial number: \_\_\_\_\_



Rooftop Equipment Warranty Registration Form (continued)

Select Yes or No. If not applicable to the type of unit, select N/A.

I. INITIAL CHECK

- A. Is any shipping damage visible?
B. Are fan drives properly aligned and belts properly adjusted?
C. Tightened all setscrews on pulleys, bearings and fans?
D. Have the hold-down bolts been backed off on spring mounted fan isolators?
E. Do fans turn freely?
F. Has the discharge static pressure reference line been properly located within the building?
G. Electrical service corresponds to unit nameplate?

G1. Voltage at Terminal Block | Disconnect 1-2 \_\_\_\_\_ V 2-3 \_\_\_\_\_ V 1-3 \_\_\_\_\_ V

- H. Is the main disconnect adequately fused and are fuses installed?
I. Are crankcase heaters operating, and have they been operating 24 hours prior to start-up?
J. Are all electrical power connections tight? (Check compressorelectrical box.)
K. Is the condensate drain trapped?

II. FAN DATA

- A. Check rotation of supply fan?
B. Voltage at supply fan motor: 1-2 \_\_\_\_\_ V 2-3 \_\_\_\_\_ V 1-3 \_\_\_\_\_ V
C. Supply fan motor amp draw per phase: L1 \_\_\_\_\_ L2 \_\_\_\_\_ L3 \_\_\_\_\_
D. Fuse sizes: \_\_\_\_\_
E. What is the supply fan rpm? \_\_\_\_\_
F. Check rotation of return fan?
G. Voltage at return fan motor: 1-2 \_\_\_\_\_ V 2-3 \_\_\_\_\_ V 1-3 \_\_\_\_\_ V
H. Return fan motor amp draw per phase: L1 \_\_\_\_\_ L2 \_\_\_\_\_ L3 \_\_\_\_\_
I. Fuse sizes: \_\_\_\_\_
J. What is the return fan rpm? \_\_\_\_\_
K. Record supply static pressure at unit in inches of H2O: \_\_\_\_\_
L. Record return static pressure at unit (with outside air dampers closed) in inches of H2O: \_\_\_\_\_



Rooftop Equipment Warranty Registration Form (continued)

Select Yes or No. If not applicable to the type of unit, select N/A.

III. START-UP COMPRESSOR OPERATION

- A. Do compressors have holding charges?
Circuit #1. . . . .  Yes  No  N/A
Circuit #2. . . . .  Yes  No  N/A
B. Are compressors rotating in the right direction? . . . . .  Yes  No  N/A
C. Do condenser fans rotate in the right direction? . . . . .  Yes  No  N/A
D. Ambient temperature (°F): . . . . . \_\_\_\_\_
E. Does unit start up and perform per sequence of operation? . . . . .  Yes  No  N/A

IV. PERFORMANCE DATA

- A. Compressor voltage across each phase: . . . . . 1-2 \_\_\_\_\_ V 2-3 \_\_\_\_\_ V 1-3 \_\_\_\_\_ V
B. Compressor amperage of fully loaded compressor: Compressor #1 — Phase 1 \_\_\_\_\_ Phase 2 \_\_\_\_\_ Phase 3 \_\_\_\_\_
Compressor #2 — Phase 1 \_\_\_\_\_ Phase 2 \_\_\_\_\_ Phase 3 \_\_\_\_\_
Compressor #3 — Phase 1 \_\_\_\_\_ Phase 2 \_\_\_\_\_ Phase 3 \_\_\_\_\_
Compressor #4 — Phase 1 \_\_\_\_\_ Phase 2 \_\_\_\_\_ Phase 3 \_\_\_\_\_
Compressor #5 — Phase 1 \_\_\_\_\_ Phase 2 \_\_\_\_\_ Phase 3 \_\_\_\_\_
Compressor #6 — Phase 1 \_\_\_\_\_ Phase 2 \_\_\_\_\_ Phase 3 \_\_\_\_\_
C. Low pressure cut-out: . . . . . Circuit 1 \_\_\_\_\_ psig Circuit 2 \_\_\_\_\_ psig
D. Low pressure cut-in: . . . . . Circuit 1 \_\_\_\_\_ psig Circuit 2 \_\_\_\_\_ psig
E. High pressure cut-out: . . . . . Circuit 1 \_\_\_\_\_ psig Circuit 2 \_\_\_\_\_ psig
F. Discharge pressure, one compressor: . . . . . Circuit 1 \_\_\_\_\_ psig Circuit 2 \_\_\_\_\_ psig
G. Discharge pressure, fully loaded, 2-3 compressors: . . . . . Circuit 1 \_\_\_\_\_ psig Circuit 2 \_\_\_\_\_ psig
H. Suction pressure, one compressor: . . . . . Circuit 1 \_\_\_\_\_ psig Circuit 2 \_\_\_\_\_ psig
I. Suction pressure, fully loaded, 2-3 compressors: . . . . . Circuit 1 \_\_\_\_\_ psig Circuit 2 \_\_\_\_\_ psig
J. Liquid press, fully loaded, 2-3 compressors (at liquid line shutoff valve): . . . Circuit 1 \_\_\_\_\_ psig Circuit 2 \_\_\_\_\_ psig
K. Liquid temperature, fully loaded, 2-3 compressors: . . . . . Circuit 1 \_\_\_\_\_ psig Circuit 2 \_\_\_\_\_ psig
L. Suction line temperature: . . . . . \_\_\_\_\_ °F \_\_\_\_\_ °F
M. Superheat: . . . . . \_\_\_\_\_ °F \_\_\_\_\_ °F
N. Subcooling: . . . . . \_\_\_\_\_ °F \_\_\_\_\_ °F
O. Is the liquid in the line sightglass clear and dry? . . . . .  Yes  No  N/A
P. Does the hot gas bypass valve function properly? . . . . .  Yes  No  N/A



Rooftop Equipment Warranty Registration Form (continued)

Select Yes or No. If not applicable to the type of unit, select N/A.

Q. At what suction pressure does the hot gas bypass valve open? . . . . .Circuit 1 \_\_\_\_\_ psig Circuit 2 \_\_\_\_\_ psig

R. Record discharge air temperature at discharge of unit: \_\_\_\_\_ °F

S. Are all control lines secure to prevent excessive vibration and wear? . . . . .  Yes  No  N/A

T. Are all gauges shut off and valve caps and packings tight after start-up? . . . . .  Yes  No  N/A

V. ELECTRIC HEAT CHECK, TEST & START

A. Electrical heat service corresponds to unit nameplate? . . . . .  Yes  No  N/A

Volts \_\_\_\_\_ Hertz \_\_\_\_\_ Phase \_\_\_\_\_

B. Are there any signs of physical damage to the electric heat coils? . . . . .  Yes  No  N/A

C. Have all electrical terminals been tightened? . . . . .  Yes  No  N/A

D. Does sequence controller stage contactors properly? . . . . .  Yes  No  N/A

E. Electric heater voltage across each phase: . . . . . \_\_\_\_\_ L1 \_\_\_\_\_ L2 \_\_\_\_\_ L3

F. Amp draw across each phase at each heating stage:

	Stage 1	Stage 2	Stage 3	Stage 4	Stage 5	Stage 6
Phase L1:	_____	_____	_____	_____	_____	_____
Phase L2:	_____	_____	_____	_____	_____	_____
Phase L3:	_____	_____	_____	_____	_____	_____

G. FLA: . . . . . L1 \_\_\_\_\_ L2 \_\_\_\_\_ L3 \_\_\_\_\_

H. Operate electric heat with fans off. Electric heat must cycle on high limit control . . . . .  Yes  No  N/A

VI. GAS BURNER CHECK, TEST, & START

Specifications:

For gas, see **Forced Draft Gas Burner Installation and Maintenance Bulletin. (IM 684 and IM 685)**

A. Gas Furnace: . . . . . Model no. \_\_\_\_\_

B. Gas Burner: . . . . . Model no. \_\_\_\_\_ Serial no. \_\_\_\_\_

C. Gas Rated firing rate (MBH input): . . . . . \_\_\_\_\_

D. Gas Altitude (ft. above sea level): . . . . . \_\_\_\_\_

E. Input (CFH): . . . . . \_\_\_\_\_

F. Gas pressure at burner (inches w.c.): . . . . . \_\_\_\_\_

G. CO<sub>2</sub> (%): . . . . . \_\_\_\_\_

H. CO<sub>2</sub> (%): . . . . . \_\_\_\_\_

I. Pilot flame only in microamps (steady at low fire): . . . . . \_\_\_\_\_

J. Pilot Tap-gas pressure (inches w.c.): . . . . . \_\_\_\_\_

K. Motor only/burner FLA running amps: . . . . . \_\_\_\_\_

L. High limit control OK? . . . . .  Yes  No  N/A

M. Flame safeguard (microamps): . . . . . \_\_\_\_\_



Rooftop Equipment Warranty Registration Form (continued)

Select Yes or No. If not applicable to the type of unit, select N/A.

- N. Flame failure shutoff (seconds): . . . . . \_\_\_\_\_
- O. Airswitch OK? . . . . .  Yes  No  N/A
- P. High Gas Pressure Switch OK? . . . . .  Yes  No  N/A
- Q. Low Gas Pressure Switch OK? . . . . .  Yes  No  N/A
- R. Main Gas Valve Close-off OK? . . . . .  Yes  No  N/A
- S. Modulation Gas Heat Performance

<b>Gas Pressure</b>	
<u>Mod. Valve</u>	<u>Reg. Valve</u>
25% _____ in Wc.	25% _____ in Wc.
50% _____ in Wc.	50% _____ in Wc.
75% _____ in Wc.	75% _____ in Wc.
100% _____ in Wc.	100% _____ in Wc.

VII. Hot Water Coil

- A. Pressure test OK? . . . . .  Yes  No  N/A

VIII. Heat Recovery

- A. Heat wheel rotates freely? . . . . .  Yes  No  N/A
- B. Heat wheel VFD operates properly? . . . . .  Yes  No  N/A
- C. Heat wheel VFD . . . . . Model No. \_\_\_\_\_ Serial No. \_\_\_\_\_
- D. Check for air bypass around heat wheel. . . . .  Yes  No  N/A

IX. Design Flow Calibration

- A. Verify power is supplied to the MicroTech III unit controller . . . . .  Yes  No  N/A
- B. Verify that the shipping screws have been removed from the measuring station vane . . . . .  Yes  No  N/A
- C. Examine station for damage . . . . .  Yes  No  N/A
- D. Record Level Position after calibration
  - LH Level Position . . . . . \_\_\_\_\_
  - RH Level Position . . . . . \_\_\_\_\_

NOTE: This is viewed in the MicroTech III controller, in the Min OA setup menu.



Rooftop Equipment Warranty Registration Form (continued)

Select Yes or No. If not applicable to the type of unit, select N/A.

X. Have all electronic or electrical controls been checked, adjusted, and tested for proper operation per the installation and maintenance bulletins?
..... [ ] Yes [ ] No [ ] N/A

XI. MAINTAINING MICROTECH CONTROL PARAMETER RECORDS

After the unit is checked, tested, and started and the final control parameters are set, record the final settings. Keep these records on file and update whenever changes to the control parameters are made. Keeping a record facilitates any required analysis and troubleshooting of the system operation and facilitates restoration after a controller replacement.

Thank you for completing this form. Please sign and date below.

Signature \_\_\_\_\_ Startup date: \_\_\_\_\_

Return completed form by mail to:

Daikin Warranty Department, 13600 Industrial Park Boulevard, Minneapolis, MN 55441
or by email to: AAH.Wty\_WAR\_forms@daikinapplied.com

Please fill out the Daikin Applied "Quality Assurance Survey Report" and list any additional comments that could affect the operation of this unit; e.g., shipping damage, failed components, adverse installation applications, etc. If additional comment space is needed, write the comment(s) on a separate sheet, attach it to the Survey Report and return it to the Warranty Department of Daikin Applied with the completed Equipment Warranty Registration form.

Submit Form

Clear Form



### Quality Assurance Survey Report

To whom it may concern:

Please review the items below upon receiving and installing our product. Select N/A on any item that does not apply to the product.

Job Name: \_\_\_\_\_ Daikin Applied S.O. No. \_\_\_\_\_

Installation address: \_\_\_\_\_

City: \_\_\_\_\_ State: \_\_\_\_\_

Purchasing contractor: \_\_\_\_\_

City: \_\_\_\_\_ State: \_\_\_\_\_

Name of person doing start-up (print): \_\_\_\_\_

Company name: \_\_\_\_\_

Address: \_\_\_\_\_

City/State/Zip: \_\_\_\_\_

Unit model number: \_\_\_\_\_ Unit serial number: \_\_\_\_\_

1. Is there any shipping damage visible? ..... Yes  No  N/A

Location on unit \_\_\_\_\_

2. How would you rate the overall appearance of the product; i.e., paint, fin damage, etc.? Excellent  Good  Fair  Poor

3. Did all sections of the unit fit together properly? ..... Yes  No  N/A

4. Did the cabinet have any air leakage? ..... Yes  No  N/A

Location on unit \_\_\_\_\_

5. Were there any refrigerant leaks? ..... Yes  No  N/A

From where did it occur? ..... Shipping  Workmanship  Design

6. Does the refrigerant piping have excessive vibration? ..... Yes  No  N/A

Location on unit \_\_\_\_\_

7. Did all of the electrical controls function at start-up? ..... Yes  No  N/A

Comments \_\_\_\_\_

8. Did the labeling and schematics provide adequate information? ..... Yes  No  N/A

9. How would you rate the serviceability of the product? Excellent  Good  Fair  Poor

10. How would you rate the overall quality of the product? Excellent  Good  Fair  Poor

11. How does the quality of Daikin Applied products rank in relation to competitive products? Excellent  Good  Fair  Poor

Comments \_\_\_\_\_

Please list any additional comments which could affect the operation of this unit; i.e., shipping damage, failed components, adverse installation applications, etc. If additional comment space is needed, write the comment(s) on a separate sheet, attach the sheet to this completed Quality Assurance Survey Report, and return it to the Warranty Department with the completed preceding "Equipment Warranty Registration Form".

# COMPLETE HVAC SYSTEM SOLUTIONS

SELF-CONTAINED | ROOFTOPS | COILS | CONDENSING UNITS  
AIR HANDLERS | WATER-COOLED CHILLERS | AIR-COOLED CHILLERS  
MODULAR CENTRAL PLANTS | SITELINE BUILDING CONTROLS  
UNIT HEATERS | FAN COILS | AIR PURIFIERS | WATER SOURCE HEAT PUMPS  
VARIABLE AIR VOLUME UNITS | UNIT VENTILATORS



13600 INDUSTRIAL PARK BLVD. | MINNEAPOLIS, MN 55441  
1-800-432-1342 | 763-553-5330

LEARN MORE AT  
**DAIKINAPPLIED.COM**

PART NUMBER: IM 971-4

© 2024 DAIKIN APPLIED | (800) 432.1342 | WWW.DAIKINAPPLIED.COM